

ABBREVIATIONS

A/C	AIR CONDITIONING		
ABV	ABOVE	MATL	MATERIAL
ADD.	ADDITIONAL	MAX.	MAXIMUM
ADJ.	ADJUSTABLE	MECH.	MECHANICAL
A.F.F.	ABOVE FINISHED FLOOR	MED.	MEDIUM
ALT.	ALTERNATE	MTL	METAL
APPROX.	APPROXIMATE(LY)	MEZZ	MEZZANINE
APT.	APARTMENT	MANUF.	MANUFACTURER
ARCH.	ARCHITECT(URAL)	MNFR.	MANUFACTURER
AWN.	AWNING	MNTR.	MONITOR
		MIN.	MINIMUM
		MISC.	MISCELLANEOUS
B.F.	BARRIER FREE		
BLDG.	BUILDING	(N)	NEW
B.O.	BOTTOM OF	N/A	NOT APPLICABLE
BTW.	BETWEEN	N.I.C.	NOT IN CONTRACT
		N.S.F.	NET SQUARE FEET
		N.T.S.	NOT TO SCALE
CAB.	CABINET	O.C.	ON CENTER
C.B.	CATCH BASIN	O.D.	OUTSIDE DIAMETER
C.I.P.	CAST IN PLACE	OPP.	OPPOSITE
CL.	CENTERLINE	OH.D.	OVERHEAD
CLS.	CLOSET	PERF.	PERFORATED
CLG.	CEILING	PERIM.	PERIMETER
CLR.	CLEAR	PERM.	PERMEABLE, PERMANENT
C.M.U.	CONCRETE MASONRY UNIT	P.LAM.	PLASTIC LAMINATE
COL.	COLUMN	PLY.	PLYWOOD
CONC.	CONCRETE	PRELIM.	PRELIMINARY
CONST.	CONSTRUCTION	PROP.	PROPERTY
CONT.	CONTINUOUS	P.S.I.	POUNDS PER SQUARE INCH
COORD.	COORDINATE	P.T.	PRESSURE TREATED,
CPT.	CARPET	P.TEN.	POST TENSIONED
CASE.	CASEMENT	PSR.	RISER
DEMO.	DEMOLISH	R/A	RETURN AIR
DIA.	DIAMETER	RAD.	RADIUS / RADIATOR
DN.	DOWN	R.C.	RESILIENT CHANNEL
D.S.	DOWNSPOUT	RCP.	REFLECTED CEILING PLAN
DET.	DETAIL	R.A.	ROOF DRAIN
D/W	DISH-WASHER	REF.	REFRIGERATOR
DWG.	DRAWING	REQ.	REQUIRED
		REQ.D.	REQUIRED
(E)	EXISTING	REV.	REVERSE, REVISION
EA.	EACH	RM.	ROOM
E.I.F.S.	EXTERIOR INSULATION AND FINISH SYSTEM	R.O.	ROUGH OPENING
		S/A	SUPPLY AIR
ELEV.	ELEVATION	SF.	SQUARE FEET
ENCL.	ENCLOSURE	SOFT.	SQUARE FEET
E.J.	EXPANSION JOINT	S.C.	SAFETY GLAZING
E.O.	EDGE OF	SHT.	SHEET
EQ.	EQUAL	SIM.	SIMILAR
EX.	EXHAUST	SML.	SMALL
EXT.	EXTERIOR	S.P.	STANDPIPE
		SPEC.	SPECIFICATION
F.D.	FLOOR DRAIN	SPKLR	SPRINKLER
FDTN.	FOUNDATION	SQ.	SQUARE
F.A.	FIRE EXTINGUISHER	S.S.	SANITARY SEWER
F.B.	FINISHED FLOOR	S.STL.	STAINLESS STEEL
FIN.	FINISHED	STL.	STEEL
FLR.	FLOOR	STC.	SOUND TRANSMISSION COEFFICIENT
F.O.	FACE OF	ST.	STORAGE
F.P.	FIREPLACE	STRUCT.	STRUCTURE, STRUCTURAL
FRM.	FRAMING	TR.	TREAD
F.R.T.	FIRE RESISTANCE TREATED	T&G	TONGUE & GROOVE
FT.	FEET	TEL.	TELEPHONE
FTG.	FOOTING	TEMP.	TEMPORARY
FURN.	FURNITURE, FURNACE	THK.	THICK(NESS)
		T.O.	TOP OF
		TTL.	TOTAL
		TYP.	TYPICAL
		U.N.O.	UNLESS NOTED OTHERWISE
GA.	GALVE	UTIL.	UTILITY
GALV.	GALVANIZED	V.C.T.	VINYL COMPOSITION TILE
G.C.	GENERAL CONTRACTOR	VERT.	VERTICAL
GL.	GLASS	V.I.F.	VERIFY IN FIELD
GR.	GRADE	W/	WITH
G.S.F.	GROSS SQUARE FEET	WD	WASHER/DRYER
GWB.	GYPNUM WALLBOARD	WO	WITHOUT
		W.C.	WATER CLOSET
		WD.	WOOD
		WIN.	WINDOW
H.B.	HOSE BIB		
HDR.	HEADER		
HDWD.	HARDWOOD		
HT.	HEIGHT		
HORIZ.	HORIZONTAL		
HR.	HOUR		
H.V.A.C.	HEATING, VENTILATION, AND AIR CONDITIONING		
I.D.	INSIDE DIAMETER		
INCL.	INCLUDED, INCLUDING		
INS.	INSULATION		
INSUL.	INSULATION		
INT.	INTERIOR		
LAM.	LAMINATED		
LAV.	LAVATORY		
LB.	POUND		
LRG.	LARGE		

SYMBOLS LEGEND (VERTICAL)

DEMO TAG	
DOOR TAG	
ELEVATION TAG	
ELEVATION SPOT TAG	
FINISH TAG	
NEW EXISTING TAG	
PLUMBING TAG	
REVISION TAG	
ROOM TAG	
SAFETY GLAZING	
SECTION CUT	
STAIR DIRECTION	
WALL ASSEMBLY TAG	
WINDOW TAG	
COLUMN GRID	
ASK TAG	
DETAIL TAG	
ELEVATION TAG	
SECTION TAG BLDG	
SECTION TAG WALL	
SECTION TAG DTL	
EXHAUST FAN	
SUPPLY GRILL	
SMOKE ALARM/CARBON MONOXIDE DETECTOR	
SMOKE ALARM	
HEAT ALARM	

WALL LEGEND

FRAMED WALL		CONCRETE	
-------------	--	----------	--

LAND USE DATA

ZONING	R 8.4
LOT AREA	8,811 SF
FLOOR AREA	3,921 SF
SETBACKS	SEE A100

BUILDING CODE DATA

APPLICABLE CODES (AS AMENDED BY CITY OF MERCER ISLAND)	MICC UNIFIED LAND DEVELOPMENT CODE 2018 WA STATE ENERGY CODE (WSEC) 2018 INTERNATIONAL FIRE CODE 2018 INTERNATIONAL RESIDENTIAL CODE (IRC) 2018 INTERNATIONAL MECHANICAL CODE (IMC) 2018 UNIFORM PLUMBING CODE (UPC)
NUMBER OF STORIES	BASEMENT + (2) TWO
NUMBER OF DWELLING UNITS	(1) SINGLE FAMILY RESIDENCE (1) ACCESSORY DWELLING UNIT

ENERGY CODE DATA

APPLICABLE CODES	2018 WA STATE ENERGY CODE (WSEC)	
CLIMATE ZONE	4C	
INSULATION AND FENESTRATION REQUIREMENTS (2018 WSEC & IRC VENTILATION WORKSHEET)	REQUIRED	PROVIDED
FENESTRATION U-FACTOR VERTICAL	U=0.30	U=0.28 MIN.
FENESTRATION U-FACTOR OVERHEAD	U=0.50	N/A
DOOR U-FACTOR	U=0.20	U=0.20
ROOF CEILING	R=49	R=49 MIN.
ROOF CEILING VAULTED	R=38	N/A
WALLS ABOVE GRADE	R=21	R=21
WALLS BELOW GRADE	R=10 (CONT EXT)	R=10 (C.I.)
FRAMED FLOOR	R=30	R=38
SLAB ON GRADE	R=10	R=10
TYPE OF HEAT	HEAT PUMP	

ENERGY CODE NOTES

- AIR BARRIER AND INSULATION INSTALLATION TO COMPLY WITH TABLE R402.4.1.1.
- ALL THERMOSTATS TO BE PROGRAMMABLE.
- MECHANICAL SYSTEM PIPING INSULATION FOR FLUIDS OVER 105 F TO BE MIN. R-6.
- INSULATION FOR HOT WATER PIPE SHALL HAVE A MIN. R-VALUE OF R-4.
- EXHAUSTS SHALL HAVE AUTOMATIC DAMPERS THAT CLOSE WHEN THE VENTILATION SYSTEM IS NOT IN USE.
- EXHAUST DUCTING SHALL BE INSTALLED IN ACCORDANCE WITH SMC 501 AND THE APPLIANCE MANUFACTURER'S INSTRUCTIONS. EXHAUST FAN AND CLOTHES DRYER DUCTWORK SHALL BE INDEPENDENT OF EACH OTHER AND TERMINATE NOT LESS THAN 3 FEET IN ANY DIRECTION FROM AN OPENING AND BE EQUIPPED WITH A BACKDRAFT DAMPER.
- RANGE HOODS SHALL DISCHARGE TO THE OUTDOORS THROUGH A SINGLE-WALL VENT AND BE EQUIPPED WITH A BACKDRAFT DAMPER.
- VERIFY LOCATION OF HVAC MECHANICAL UNITS WITH ARCHITECT.
- WHOLE HOUSE VENTILATION SYSTEM FANS SHALL MEET THE EFFICACY REQ. OF TABLE SMC 403.4.6.5.
- A MINIMUM OF 90% OF PERMANENTLY INSTALLED LAMPS IN LIGHTING FIXTURES SHALL BE HIGH-EFFICACY LAMPS.
- A PERMANENT CERTIFICATE IS TO BE COMPLETED AND POSTED ON OR WITHIN THREE FEET OF THE ELECTRICAL DISTRIBUTION PANEL BY THE BUILDER OR REGISTERED DESIGN PROFESSIONAL. REF. SREC R401.3.
- AT LEAST ONE THERMOSTAT SHALL BE PROVIDED FOR EACH SEPARATE HEATING AND COOLING SYSTEM. REF. SREC R403.1.

ADDITIONAL ENERGY EFFICACY REQUIREMENTS PER R406.2 FOR MEDIUM DWELLING UNIT: 6.0 CREDITS REQUIRED

PRIMARY HEAT SOURCE SYSTEM TYPE:
HO-2 1.0 CREDITS HEAT PUMP - AIR TO AIR | WATER UNITS CONFIGURED TO PROVIDE HEATING AND COOLING, RATED IN ACCORDANCE WITH AHRI 550/5990

ENERGY CREDITS:	EFFICIENT BUILDING ENVELOPE
1.3 0.5 CREDITS	FENESTRATION MIN. U= .28 FLOOR MIN. = R-38 SLAB ON GRADE MIN. = R-10 PERIMETER AND UNDER ENTIRE SLAB
5.4 1.5 CREDITS	EFFICIENT WATER HEATING ELECTRIC HEAT PUMP WATER HEATER MEETING TIER 1 OF NEEA'S ADVANCED WATER HEATING SPECIFICATION
6.1 3.0 CREDITS	RENEWABLE ELECTRIC ENERGY 3.6 KW SOLAR PANEL ARRAY

TOTAL CREDITS = 6.0

GENERAL NOTES

- ALL WORK SHALL BE DONE IN CONFORMANCE WITH ALL APPLICABLE CODES.
- DIMENSIONS ARE TO FACE OF STUD AND FACE OF CONCRETE UNLESS NOTED OTHERWISE.
- DO NOT SCALE DRAWINGS.
- IT IS THE CONTRACTOR'S RESPONSIBILITY TO REPORT DISCREPANCIES FOUND WITHIN THESE DOCUMENTS TO THE ARCHITECT AS SOON AS THEY ARE DISCOVERED.
- DRAWINGS INDICATE GENERAL AND TYPICAL DETAILS OF CONSTRUCTION. WHERE CONDITIONS ARE NOT SPECIFICALLY INDICATED BUT ARE OF SIMILAR CHARACTER TO DETAILS SHOWN, SIMILAR DETAILS OF CONSTRUCTION SHALL BE USED, SUBJECT TO REVIEW AND APPROVAL BY THE ARCHITECT.
- CONTRACTOR SHALL VERIFY ALL DIMENSIONS, EXISTING CONDITIONS, AND MEMBER SIZES PERTAINING TO THE WORK PRIOR TO PROCEEDING. ALL DIMENSIONS OF EXISTING CONDITIONS SHOWN ON THE DRAWINGS ARE INTENDED AS GUIDELINES ONLY AND MUST BE VERIFIED. THE ARCHITECT MUST BE NOTIFIED IN WRITING OF ANY VARIATION FROM THE DIMENSIONS AND/OR CONDITIONS SHOWN ON THESE DRAWINGS. ANY SUCH VARIATION SHALL BE RESOLVED BY THE ARCHITECT PRIOR TO THE CONTRACTOR PROCEEDING WITH THE WORK. OR THE CONTRACTOR SHALL ACCEPT FULL RESPONSIBILITY FOR COST TO RECTIFY THE SAME.
- CONTRACTOR SHALL PROVIDE TEMPORARY BRACING FOR THE STRUCTURE AND STRUCTURAL COMPONENTS UNTIL ALL FINAL CONNECTIONS HAVE BEEN COMPLETED IN ACCORDANCE WITH THE PLANS.
- CONTRACTOR SHALL BE RESPONSIBLE FOR SAFETY PRECAUTIONS AND THE MEANS AND METHODS TO PERFORM THE WORK.
- EACH SUB-CONTRACTOR SHALL BE RESPONSIBLE FOR THE JOINING OF HIS WORK TO THE WORK OF OTHER TRADES.
- CONTRACTOR SHALL PROVIDE BLOCKING AS REQUIRED FOR ALL CASEWORK, FIXTURE, AND SPECIALTY ITEMS.
- WINDOW DIMENSIONS ARE ROUGH OPENING IN INCHES. ALL WINDOW AND DOOR SIZES SHALL BE VERIFIED AND FIELD MEASURED PRIOR TO FABRICATION.
- REQUIRED SPECIFICATIONS FOR CONCRETE.
- PROJECT SHALL REMOVE JAPANESE KNOTWEED (POLYGONUM OSPERATUM) AND REGULATED CLASS A REGULATED CLASS B AND REGULATED CLASS C WEEDS IDENTIFIED ON THE KING COUNTY NOXIOUS WEED LIST, AS AMENDED, FROM REQUIRED LANDSCAPING AREAS ESTABLISHED PURSUANT TO MICC 19.02.020.(F)(3)(a). NEW LANDSCAPING SHALL NOT INCORPORATE ANY WEEDS IDENTIFIED ON THE KING COUNTY NOXIOUS WEED LIST, AS AMENDED. PROVIDED, THAT REMOVAL SHALL NOT BE REQUIRED IF THE REMOVAL WILL RESULT IN INCREASED SLOPE INSTABILITY OR RISK OF LANDSLIDE OR EROSION.

GENERAL RESIDENTIAL CODE NOTES

- BATHROOM FIXTURES SHALL BE SPACED IN ACCORDANCE WITH FIGURE R307.1.
- EACH PANE OF GLAZING INSTALLED IN A HAZARDOUS LOCATION AS DEFINED BY SECTION R308.4 SHALL BE PROVIDED WITH A MANUFACTURER'S DESIGNATION.
- AN APPROVED SMOKE ALARM SHALL BE LOCATED IN EACH SLEEPING ROOM, OUTSIDE OF EACH SEPARATE SLEEPING AREA IN THE IMMEDIATE VICINITY OF THE BEDROOMS, AND ON EACH ADDITIONAL STORY OF THE DWELLING. THE SMOKE ALARM DEVICES SHALL BE INTERCONNECTED AND POWERED BY PRIMARY POWER WITH A BATTERY BACKUP.
- AN APPROVED CARBON MONOXIDE ALARM SHALL BE INSTALLED OUTSIDE OF EACH SEPARATE SLEEPING AREA.
- WOOD AND WOOD BASED PRODUCTS SHALL BE PROTECTED AGAINST DECAY WHEN INSTALLED IN LOCATIONS PER R317.1.
- ALL FASTENERS AND CONNECTORS IN CONTACT WITH PRESERVATIVE TREATED AND FIRE-RETARDANT-TREATED WOOD SHALL BE HOT DIPPED ZINC-COATED GALVANIZED STEEL, STAINLESS STEEL, SILICONE BRONZE OR COPPER. COATING TYPE AND WEIGHTS FOR CONNECTORS SHALL BE IN ACCORDANCE WITH THE CONNECTOR MANUFACTURER'S RECOMMENDATIONS.
- ALL GUARD RAILS ARE DESIGNED IN CONFORMANCE WITH SRC R312. THE MAXIMUM OPENING OF ALL GUARD RAIL INFILL IS 4" MAXIMUM SUCH THAT A 4-INCH SPHERE CANNOT PASS THROUGH.
- ALL GUARD RAIL IN-FILL COMPONENTS ARE DESIGNED TO WITHSTAND A HORIZONTALLY NORMAL APPLIED LOAD OF 50 PSF ON AN AREA EQUAL TO 1 FOOT PER R301.5. ALL TOP RAILS ARE DESIGNED TO RESIST A 200 LB CONCENTRATED LOAD PER R301.5.
- HANDRAILS ARE DESIGNED IN CONFORMANCE WITH R311.7.8.

VENTILATION DATA

WHOLE HOUSE VENTILATION TO BE PROVIDED PER M1505.4 WHOLE HOUSE VENTILATION USING A HEAT RECOVERY SYSTEM. ALL DUCT WORK IN HEAT RECOVERY SYSTEMS SHALL BE SIZED AND INSTALLED PER THE MANUFACTURER'S INSTRUCTIONS. SYSTEM MINIMUM FLOW RATING SHALL NOT BE LESS THAN THAT SPECIFIED IN TABLE M1505.4.3(1). HEAT RECOVERY VENTILATION SYSTEMS SHALL HAVE A FILTER ON THE UPSTREAM SIDE OF THE HEAT EXCHANGER IN BOTH THE INTAKE AND EXHAUST AIRSTREAMS WITH A MINIMUM EFFICIENCY RATING VALUE (MERV) OF 6.

ALL SUPPLY DUCTS IN THE CONDITIONED SPACE INSTALLED UPSTREAM OF THE HEAT EXCHANGER SHALL BE INSULATED TO A MINIMUM OF R-4.

WHOLE HOUSE VENTILATION SUPPLY AND EXHAUST FANS SHALL HAVE A MINIMUM EFFICACY AS PRESCRIBED IN THE WASHINGTON STATE ENERGY CODE.

OUTDOOR AIR INLETS SHALL BE SCREENED OR OTHERWISE PROTECTED FROM ENTRY BY LEAVES OR OTHER MATERIAL. OUTDOOR AIR INLETS SHALL BE LOCATED SO AS NOT TO TAKE AIR FROM THE FOLLOWING AREAS:

- CLOSER THAN 10 FEET FROM AN APPLIANCE VENT OUTLET, UNLESS SUCH VENT OUTLET IS 3 FEET ABOVE THE OUTDOOR AIR INLET.
- WHERE IT WILL PICK UP OBJECTIONABLE ODORS, FUMES, OR FLAMMABLE VAPORS.
- A HAZARDOUS OR UNSANITARY LOCATION.
- A ROOM OR SPACE HAVING ANY FUEL-BURNING APPLIANCES THEREIN.
- CLOSER THAN 10 FEET FROM A VENT OPENING OF A PLUMBING DRAINAGE SYSTEM UNLESS THE VENT OPENING IS AT LEAST 3 FEET ABOVE THE AIR INLET.
- ATTIC, CRAWL SPACES, OR GARAGES.

DWELLING UNIT FLOOR AREA (3001-4500 SF / 5 BEDROOMS)
TABLE M1505.4.3(1) REQ'D AIRFLOW = 90 CFM
TABLE M1505.4.3(2) CONTINUOUSLY
REQUIRED CFM = 90 X 1 = 90 CFM
PROVIDE (1) 100 CFM ERV, DUCTED AND PROVIDE SUPPLY AND EXHAUST AIR GRILLS PER PLAN SPEC. PANASONIC FV-10VEC2

LOCAL EXHAUST SHALL BE PROVIDED IN EACH TOILET ROOMS, KITCHEN, AND BATHROOM. LOCAL EXHAUST SYSTEMS SHALL BE DESIGNED TO HAVE THE CAPACITY TO EXHAUST THE MINIMUM AIR FLOW RATE DETERMINED IN ACCORDANCE WITH TABLE M1505.4.4. LOCAL EXHAUST SYSTEMS SHALL BE PROVIDED WITH CONTROLS THAT ENABLE MANUAL OVERRIDE OR AUTOMATIC OCCUPANCY SENSOR, HUMIDITY SENSOR OR POLLUTANT SENSOR CONTROLS. LOCAL EXHAUST SYSTEM CONTROLS SHALL BE READILY ACCESSIBLE.

FULL DETAIL OF HEAT RECOVERY VENTILATION SYSTEM SHALL BE PROVIDED BY SEPARATE MECHANICAL PERMIT.

FIRE PROTECTION

- FIRE AREA SQUARE FOOTAGE = 4,793 SF
- NFPA 13R FIRE SPRINKLER SYSTEM TO BE INSTALLED PER NFPA 13R AND COMI STANDARDS. A SEPARATE FIRE PERMIT IS REQUIRED.
 - MONITORED FIRE ALARM SYSTEM TO BE INSTALLED PER NFPA 72 CHAPTER 29, COMI AND NFPA 72 STANDARDS. A SEPARATE FIRE PERMIT IS REQUIRED.

LIST OF DRAWINGS

G000	PROJECT INFORMATION
G100	LAND USE CALCULATIONS
	SURVEY
	STORMWATER SITE PLAN
	SWPPP DETAILS
L1	LANDSCAPE PLAN
L2	LANDSCAPE PLAN
A000	ASSEMBLIES
A100	SITE PLAN
A200	FOUNDATION PLAN
A201	BASEMENT PLAN
A202	LEVEL 1 PLAN
A203	LEVEL 2 PLAN
A204	ROOF PLAN
A300	ELEVATIONS
A301	ELEVATIONS
A400	BUILDING SECTIONS
A401	BUILDING SECTIONS
A900	WINDOW/DOOR SCHEDULES
S1.0	GENERAL STRUCTURAL NOTES
S1.1	GENERAL STRUCTURAL NOTES
S2.0	LOWER FOUNDATION PLAN
S2.1	MAIN FLOOR FRAMING & UPPER FOUNDATION PLAN
S2.2	MAIN FLOOR CEILING FRAMING PLAN
S2.3	UPPER FLOOR FRAMING PLAN
S2.4	ROOF FRAMING PLAN
S3.0	STRUCTURAL DETAILS
S3.1	STRUCTURAL DETAILS
S3.2	STRUCTURAL DETAILS
S3.3	STRUCTURAL DETAILS
S3.4	STRUCTURAL DETAILS

CONTACTS

ARCHITECT: WORKSHOP AD, LLC 310 S WASHINGTON ST SEATTLE, WA 98104	CIVIL ENGINEER: GREEN LAKE ENGINEERING 6045 4TH AVE NE SEATTLE, WA 98115
CONTACT: STEVE BULL, AIA 206.903.5414 steveb@workshopad.com	CONTACT: ROBERT M. KEHRLI 206.898.4269 bob.kehrli@greenlakeengineering.com
STRUCTURAL ENGINEER: SMITHLUBKE STRUCTURAL DESIGN P.O. BOX 30954 SEATTLE, WA 98113	LANDSCAPE ARCHITECT: ROOT OF DESIGN KOHLES PROFESSIONAL CENTER 26231 72ND AVENUE NW, SUITE 201 STANWOOD, WA 98292
CONTACT: JULIE SMITH LUBKE 206.852.1536 julie@smithlubke.com	CONTACT: DEVIN PETERSON 206.491.9545 devin@rootofdesign.com

GEOTECH:
GEO GROUP NORTHWEST, INC.
13705 BEL-RED ROAD
BELLEVUE, WASHINGTON 98005

CONTACT: KEITH JOHNSON
425.649.8757
kjohnson@geogroupprnw.com

PROJECT INFORMATION

PROJECT DESCRIPTION:
DEMOLITION OF EXISTING SINGLE FAMILY RESIDENCE & DETACHED CARPORT.
CONSTRUCTION OF NEW SINGLE FAMILY RESIDENCE & ATTACHED ACCESSORY DWELLING UNIT.

PROJECT ADDRESS:
3064 68TH AVE SE
MERCER ISLAND, WA 98040

LEGAL DESCRIPTION:
LOTS 4 AND 5, BLOCK 39, EAST SEATTLE BLOCKS 39 & 40, ACCORDING TO THE PLAT THEREOF RECORDED IN VOLUME 4 OF PLATS, PAGE 21, RECORDS OF KING COUNTY, WASHINGTON; SITUATE IN THE CITY OF MERCER ISLAND, COUNTY OF KING, STATE OF WASHINGTON.

APN: 217510-0020

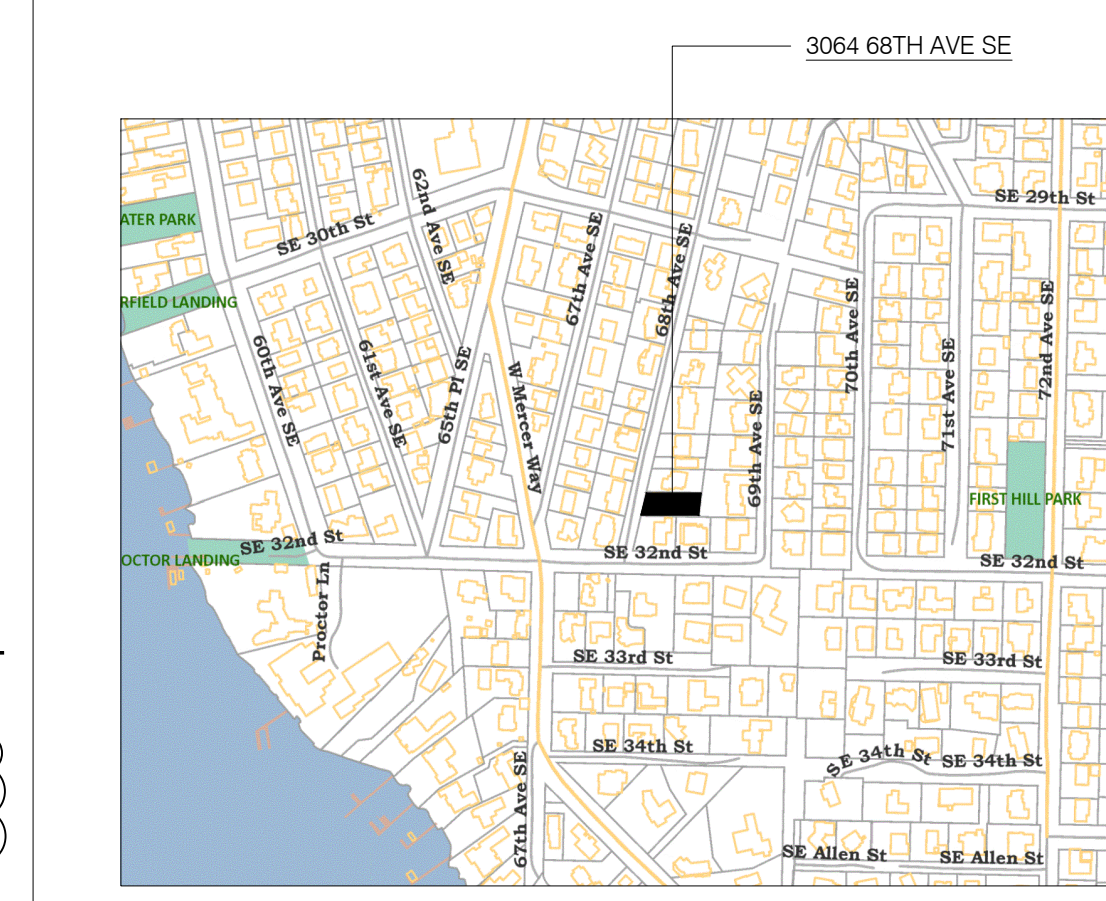

Owner Name
SAM FRANKLIN + JUNE CADENHEAD

Project Address
3064 68TH AVE SE
MERCER ISLAND, WA 98040

Sheet Information	
Job Number	2209
Drawn	DR / TL
Checked	SB
Title	PROJECT INFO

GFA CALCULATIONS

GROSS FLOOR AREA CALCULATIONS			
LOT AREA			8,811
FLOOR AREA RATIO		40%	
MAX ALLOWABLE GFA			3,524
ADU ALLOWANCE			
	LESS OF 5% OF LOT OR		
	ADU GFA		441
	5% OF LOT		441
	ADU GFA		460
MAX ALLOWABLE GFA WITH ADU ALLOWANCE			3,965
SFR			
	GFA	EXCLUDE PER APPENDIX B	CHARGABLE GFA
BASEMENT	1,398	547	
LEVEL 1	1,697	1,897	
L1 COVER DECK	134		134
STAIR EXCLUDE PER			
LEVEL 2	1,521	43	1,478
L2 COVER DECK	44		44
			3,900
			COMPLIES

BASEMENT GFA EMPT - TABLE OF WALL LENGTHS AND COVERAGE					
SEGMENT	LENGTH	M.P. HEIGHT	TOTAL WALL HEIGHT	COVERAGE %	RESULT
W1	42.50	0.00	8.50	0%	0.00
S1	22.00	2.70	8.50	32%	6.99
E1	6.50	5.50	8.50	95%	4.21
S2	6.00	6.80	8.50	80%	4.80
E2	13.33	8.00	8.50	94%	12.55
S3	28.50	8.50	8.50	100%	28.50
E3	8.67	8.50	8.50	100%	8.67
N1	28.50	8.50	8.50	100%	28.50
E4	14.00	8.00	8.50	94%	13.18
N2	28.00	4.00	8.50	47%	13.18
TOTAL	198.00				120.56
EXCLUDED FROM GFA (PERCENTAGE AND AREA)				60.89%	851

NOTE:
REFER TO A300, A301, 2/A401 FOR WALL M.P. HEIGHT
PORTION OF EXCLUDED BASEMENT:
1398 SF x 60.89% = 851 SF EXCLUDED FROM GFA

AVG BUILDING ELEVATION CALCULATIONS

AVERAGE BUILDING ELEVATION			
midpoint elevation	façade length	(length x elev)	
W1	42.50	5652.5	
S1	22.00	2985.4	
E1	138.5	900.3	
S2	138.8	838.8	
E2	141.0	1879.5	
S4	142.0	1704.0	
W2	143.0	1906.2	
S5	146.8	2392.5	
E5	145.5	5238.0	
N3	145.0	2409.0	
W3	143.0	2002.0	
N4	142.0	1704.0	
E4	141.0	1974.0	
N2	137.0	3836.0	
		35422.2	total
		252.7	total length
		140.2	average elev (total / total length)
		170.2	30' height limit

LOT SLOPE CALCULATION

HIGHEST PT ELEVATION: +164.0'
LOWEST PT ELEVATION: +121.8'
ELEVATION DIFFERENCE: 42.2'
HORIZONTAL DISTANCE BETWEEN HIGH AND LOW PT: 147.5'
LOT SLOPE = 42.2' / 147.5' = 28.6 %

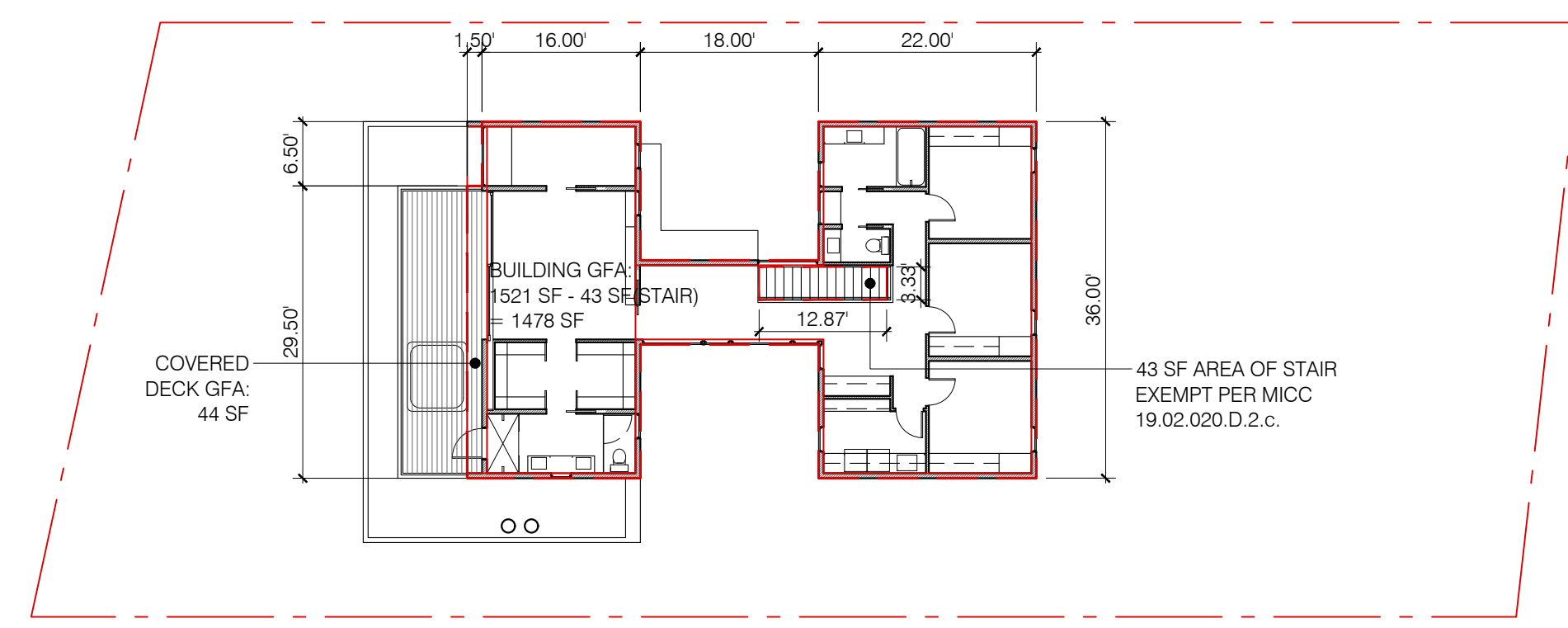

LEVEL 2

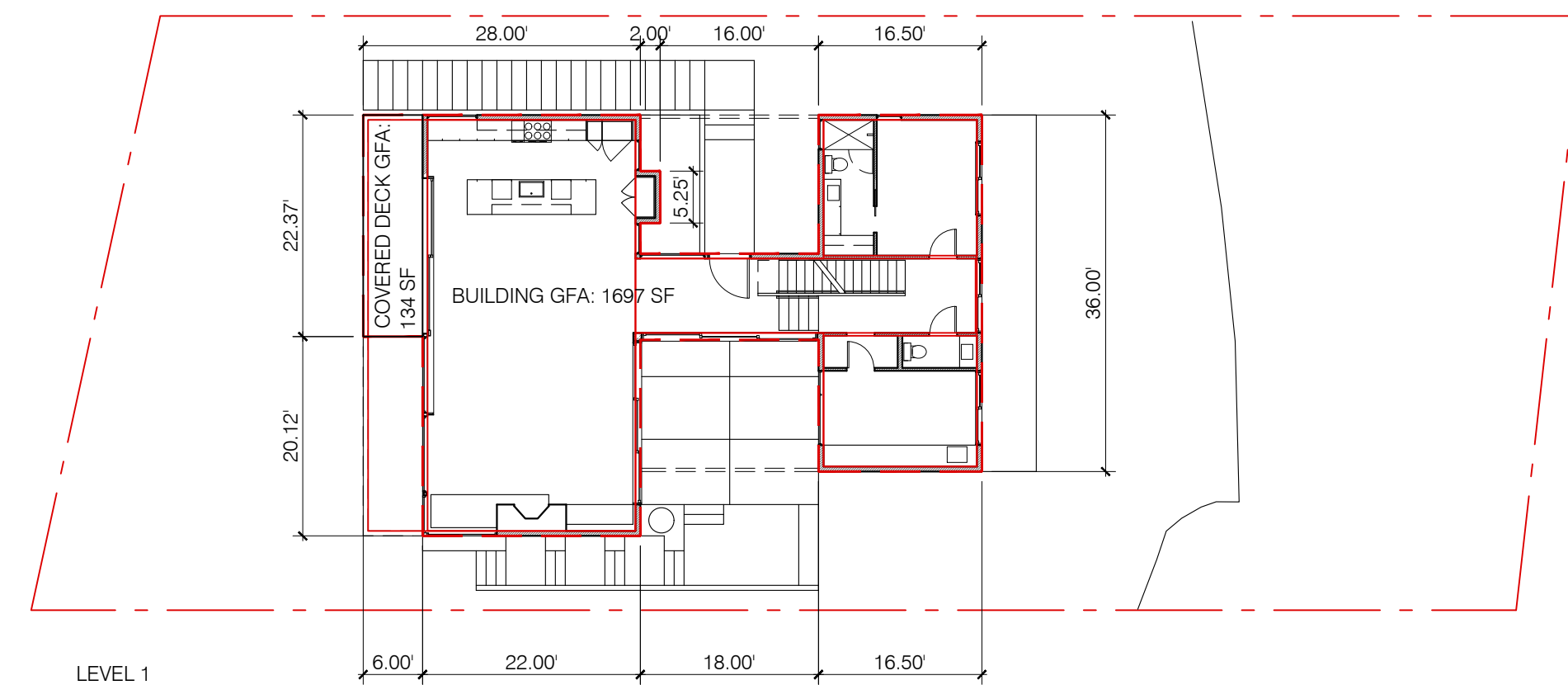

LEVEL 1

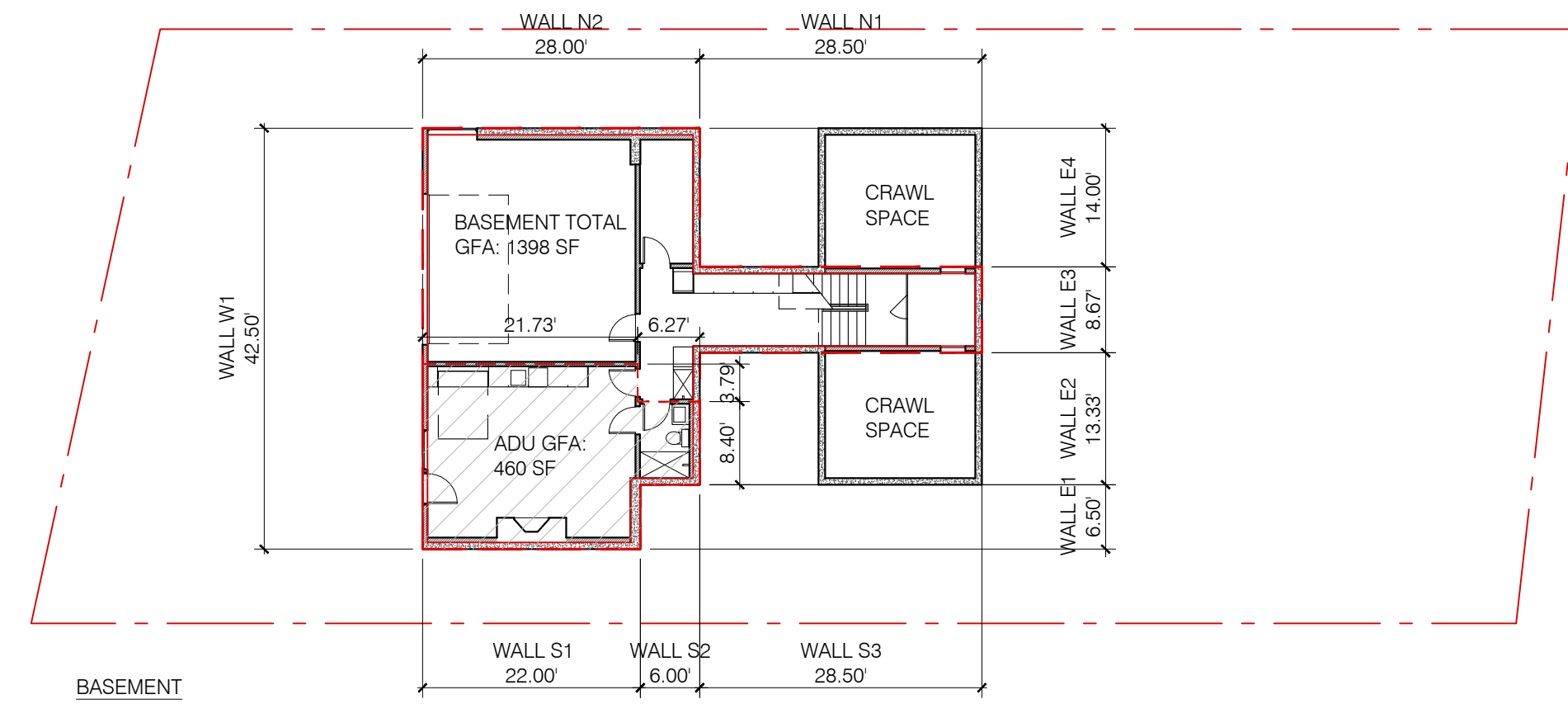

NOTE: ADU GFA INCLUDED IN BASEMENT TOTAL GFA

2 GFA DIAGRAMS
1/16" = 1'-0"

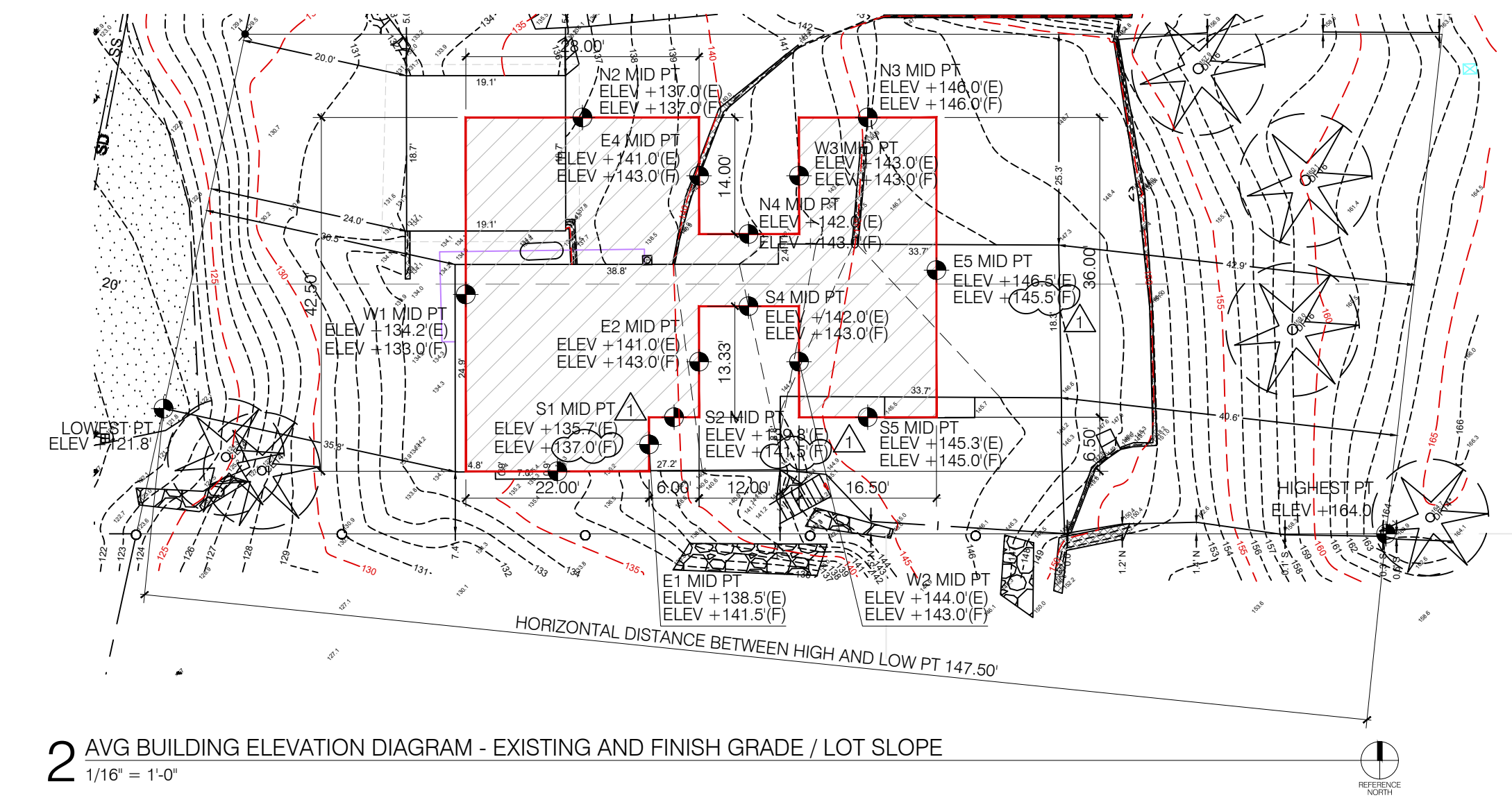

LOT COVERAGE AND HARDSCAPE CALCULATIONS

LOT COVERAGE CALCULATION			
LOT AREA			8,811
MAX COVERAGE (35%)			3,084
PROPOSED COVERAGE			
	BUILDING	2,320	
	DRIVEWAY	638	
TOTAL		2,958	COMPLIES
MAX HARDSCAPE (9%)			
		793	
PROPOSED HARDSCAPE			
	H1	255	
	H2	462	
TOTAL		717	COMPLIES

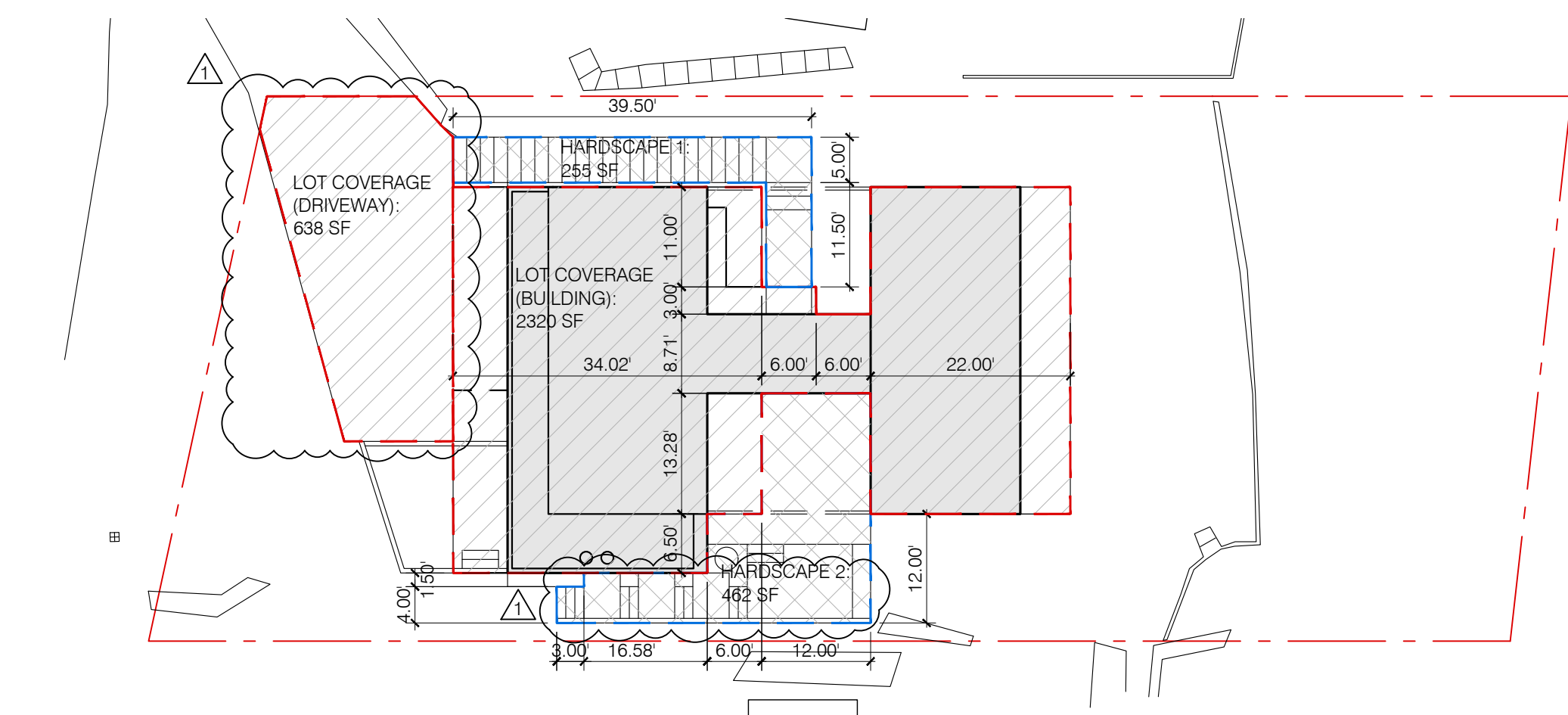

1 LOT COVERAGE PLAN DIAGRAM
1/16" = 1'-0"

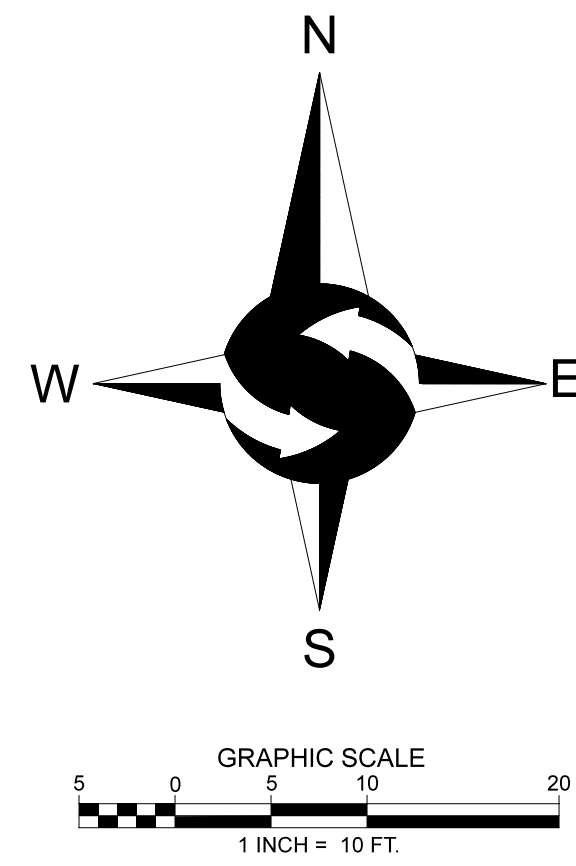

LEGEND

- | | | | |
|--|---|--|-------------------------|
| | FOUND MONUMENT IN CASE | | OHP— OVERHEAD POWER |
| | FOUND REBAR AS DESCRIBED | | —X— CHAINLINK FENCE |
| | SET MAG NAILS AS DESCRIBED | | —□— WOOD FENCE |
| | POWER METER | | — — WIRE FENCE |
| | UTILITY POLE | | —/— TIMBER WALL |
| | MAILBOX | | —/— CONCRETE WALL |
| | STORM DRAIN MANHOLE | | ROCKERY |
| | CATCH BASIN SOLID LID | | ASPHALT SURFACE |
| | CATCH BASIN | | CONCRETE SURFACE |
| | SANITARY SEWER MANHOLE | | GRAVEL SURFACE |
| | WATER VALVE | | BRICK SURFACE |
| | FIRE HYDRANT | | CE CEDAR |
| | WATER METER | | DF DOUGLAS FIR |
| | —SS— APPROXIMATE LOCATION SANITARY SEWER LINE | | * INDICATES MULTI-TRUNK |
| | —SD— APPROXIMATE LOCATION STORM DRAIN LINE | | |
| | —G— APPROXIMATE LOCATION UNDERGROUND GAS LINE | | |
| | —W— APPROXIMATE LOCATION UNDERGROUND WATER LINE | | |

LEGAL DESCRIPTION

LOTS 4 AND 5, BLOCK 39, EAST SEATTLE BLOCKS 39 & 40, ACCORDING TO THE PLAT THEREOF RECORDED IN VOLUME 4 OF PLATS, PAGE 21, RECORDS OF KING COUNTY, WASHINGTON. SITUATE IN THE CITY OF MERCER ISLAND, COUNTY OF KING, STATE OF WASHINGTON.

BASIS OF BEARINGS

RECORD OF SURVEY BY TERRANE FOR LOUIE SCALZO, RECORDED ON OCTOBER 19, 2017, IN VOLUME 372 OF SURVEYS, PAGES 200 AND 201, UNDER RECORDING NO. 20171019900001, RECORDS OF KING COUNTY, WASHINGTON.

PROJECT INFORMATION

PROPERTY OWNER: MARY KAY NELSON
3064 68TH AVENUE SE
MERCER ISLAND, WA 98040

TAX PARCEL NUMBER: 217510-0020

PROJECT ADDRESS: 3064 68TH AVENUE SE
MERCER ISLAND, WA 98040

ZONING: R-8.4

JURISDICTION: CITY OF MERCER ISLAND

PARCEL ACREAGE: 8.811 S.F. (0.202 ACRES) AS SURVEYED

GENERAL NOTES

- THIS SURVEY WAS COMPLETED WITHOUT BENEFIT OF A CURRENT TITLE REPORT. EASEMENTS AND OTHER ENCUMBRANCES MAY EXIST ON THIS PROPERTY THAT ARE NOT SHOWN HEREON.
- INSTRUMENTATION FOR THIS SURVEY WAS A 3-SECOND SPECTRAPRECISION FOCUS 35 TOTAL STATION AND AN EMLID REACH RS2 GPS RECEIVER. PROCEDURES USED IN THIS SURVEY MEET OR EXCEED STANDARDS SET BY WAC 332-130-090.
- THE INFORMATION ON THIS MAP REPRESENTS THE RESULTS OF A SURVEY MADE IN MAY 2022 AND CAN ONLY BE CONSIDERED AS INDICATING THE GENERAL CONDITIONS EXISTING AT THAT TIME.
- UTILITIES SHOWN ON THIS SURVEY ARE BASED UPON ABOVE GROUND OBSERVATIONS AND AS-BUILT PLANS WHERE AVAILABLE. ACTUAL LOCATIONS OF UNDERGROUND UTILITIES MAY VARY AND UTILITIES NOT SHOWN ON THIS SURVEY MAY EXIST ON THIS SITE.
- ALL MONUMENTS WERE LOCATED DURING THIS SURVEY UNLESS OTHERWISE NOTED.

VERTICAL DATUM & CONTOUR INTERVAL

ELEVATIONS SHOWN ON THIS DRAWING WERE DERIVED FROM INFORMATION PROVIDED BY WCCS SURVEY CONTROL DATABASE.

THE MARK IS A MONUMENT IN CASE AT THE INTERSECTION OF SE 32ND STREET AND 68TH AVENUE NE.

POINT ID NO. 502.
ELEVATION: 112.571 FEET - NAVD 88

1.0' CONTOUR INTERVAL - THE EXPECTED VERTICAL ACCURACY IS EQUAL TO 1/2 THE CONTOUR INTERVAL OR PLUS / MINUS 0.5' FOR THIS PROJECT.

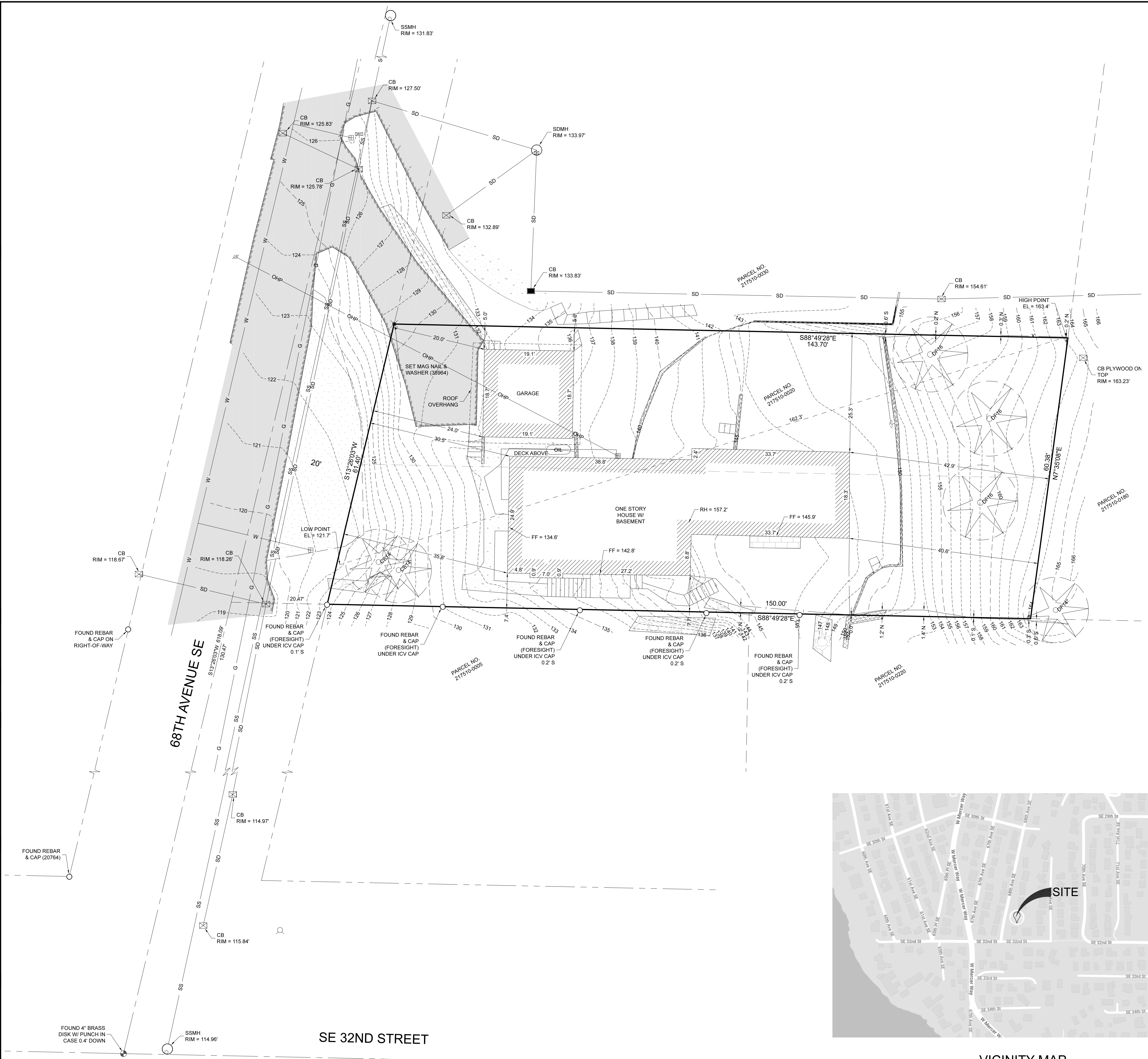

VICINITY MAP
NTS

SW 1/4, NW 1/4, SEC 12, TWP 24N, RNG 4E, W.M.

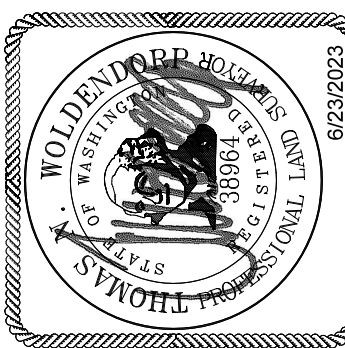

DATE	REVISION	DRN

TOPOGRAPHIC SURVEY

SAM FRANKLIN
3064 68TH AVENUE SE
MERCER ISLAND, WA 98040

PROJECT NO. 22-254

DRAWN BY: MTS
CHECKED BY: TNW
DATE: 5/4/2022

SHEET 1 OF 1



VICINITY MAP

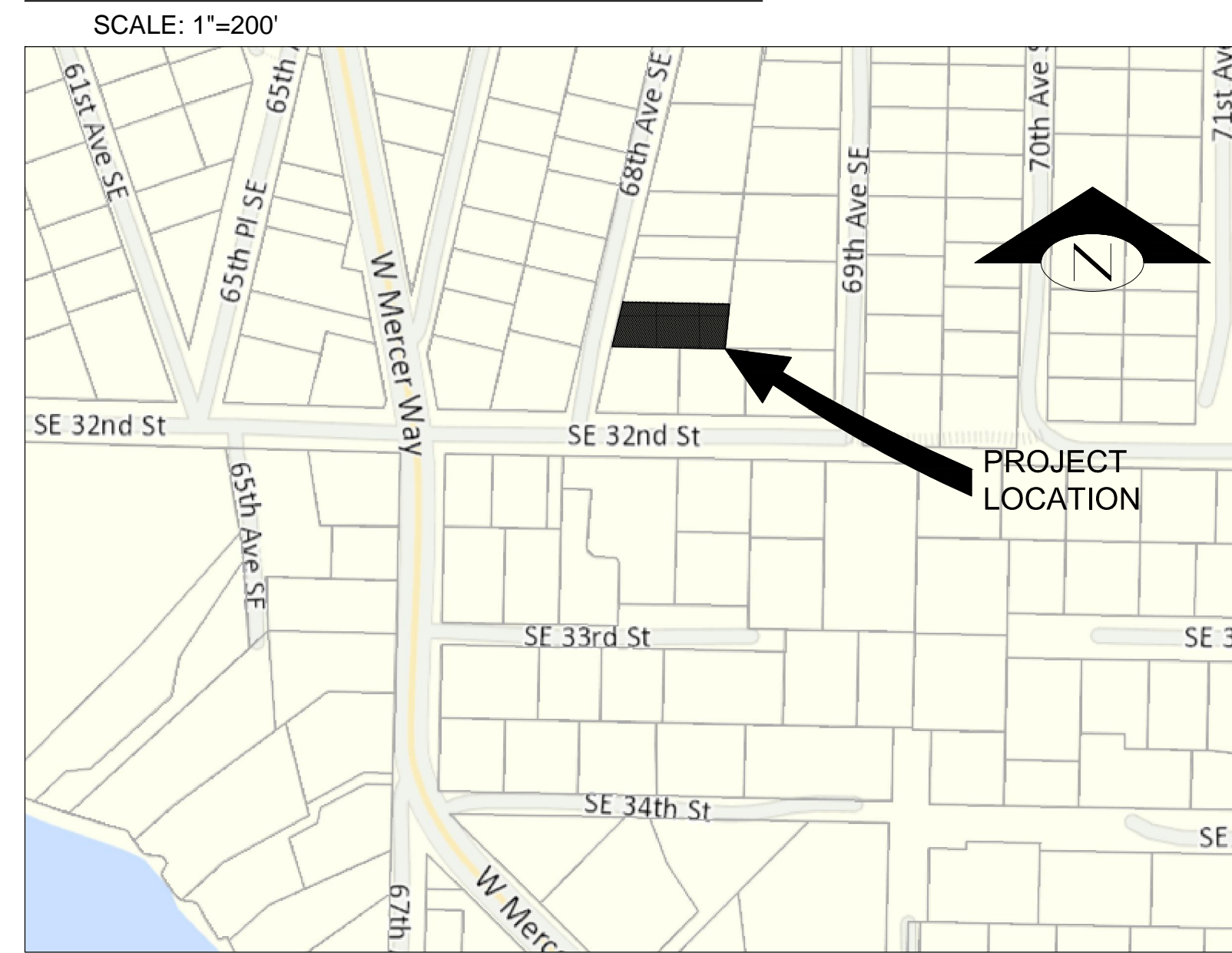

LEGAL DESCRIPTION

LOTS 4 AND 5, BLOCK 39, EAST SEATTLE BLOCKS 39 & 40, ACCORDING TO THE PLAT THEREOF RECORDED IN VOLUME 4 OF PLATS, PAGE 21, RECORDS OF KING COUNTY, WASHINGTON:

SITUATE IN THE CITY OF MERCER ISLAND, COUNTY OF KING, STATE OF WASHINGTON.

NOTES

1. THE CONTRACTOR SHALL PROTECT EXISTING PAVEMENT TO REMAIN. IF ROADWAY SURFACE IS DISTURBED DURING CONSTRUCTION THE CONTRACTOR SHALL COORDINATE RESTORATION LIMITS WITH THE INSPECTOR.
2. ALL ON-SITE STORM LINES SHALL BE 6" PVC, HAVE A MINIMUM 2% SLOPE, AND A MINIMUM COVER OF 1.0' IN LANDSCAPED AREAS AND 2.0' IN AREAS SUBJECT TO VEHICULAR TRAFFIC, UNLESS OTHERWISE NOTED.
3. CONTRACTOR TO VERIFY SIZE, LOCATION AND CONDITION OF EX SSS TO BE REUSED. THE TV INSPECTION OF THE EXISTING SIDE SEWER TO THE CITY SEWER MAIN ON 68TH AVE SE IS REQUIRED PRIOR TO ANY WORK RELATED TO THE SIDE SEWER. IF THE RESULT OF THE TV INSPECTION IS NOT IN SATISFACTORY CONDITION, AS DETERMINED BY THE CITY OF MERCER ISLAND INSPECTOR, THE REPLACEMENT OF THE EXISTING SIDE SEWER IS REQUIRED.
4. PROJECT PROPOSES TO PRODUCE APPROXIMATE 550 CUBIC YARDS OF CUT RELATED TO EXCAVATION FOR CONSTRUCTION OF THE PROPOSED BASEMENT. EXCAVATED SOILS SHALL BE HAULED OFF-SITE.
5. NEW 2-INCH WATER SERVICE WITH 1.5-INCH METER PER STANDARD DETAIL W-14. REFER TO WATER SERVICE PERMIT FOR ACTUAL LOCATION OF NEW WATER METER AND SERVICE LINE BY MERCER ISLAND WATER DEPARTMENT.
6. IF THE EXISTING CATCH BASIN IS NOT IN SATISFACTORY CONDITION, AS DETERMINED BY THE CITY OF MERCER ISLAND INSPECTOR, THE REPLACEMENT OF THE EXISTING CATCH BASIN IS REQUIRED.
7. ESTIMATED INVERT OF EXISTING SIDE SEWER SHOWN ON PLANS. MINIMUM SLOPE OF 4" SANITARY SEWER LATERAL SHALL BE 2%. PIPE SHALL BE PVC SDR 3034 OR APPROVED EQUIVALENT.



Green Lake Engineering, LLC
6045 4th Ave. NE
Seattle, WA 98115
Phone: 206-898-4269

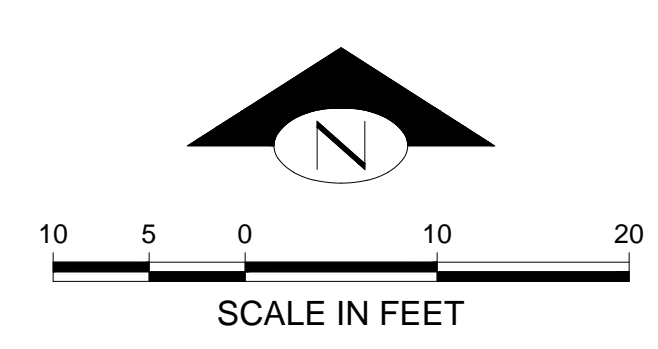
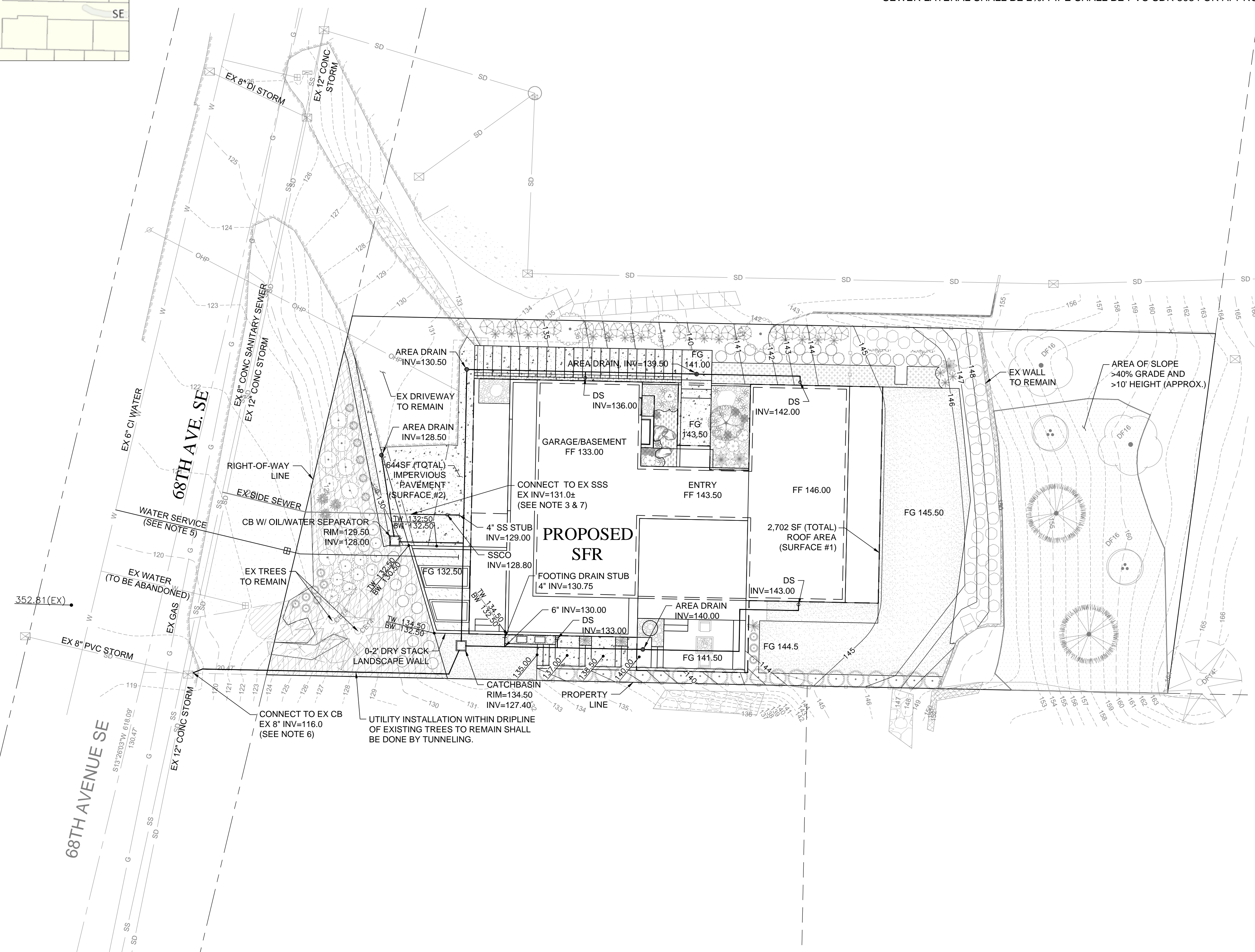

68TH AVE SE
BUILDING PERMIT SUBMITTAL

BUILDING PERMIT SUBMITTAL
12.30.2022
REVISED BUILDING PERMIT SUBMITTAL
07.14.2023

Jurisdiction Review

Owner Name
SAM FRANKLIN + JUNE CADENHEAD
Project Address
3064 68TH AVE SE
MERCER ISLAND, WA 98040

Sheet Information
Job Number 2209
Drawn RMK
Checked RMK
Title

**STORMWATER
SITE PLAN**

Sheet

PREPARED BY GREEN LAKE ENGINEERING, LLC



Green Lake Engineering, LLC
 6045 4th Ave. NE
 Seattle, WA 98115
 Phone: 206-898-4269



NOTES

- AREAS REQUIRED TO PROVIDE POST-CONSTRUCTION SOIL QUALITY AND DEPTH PER MINIMUM REQUIREMENT #5 SHALL PROVIDE A TOPSOIL LAYER WITH A MINIMUM ORGANIC MATTER CONTENT OF TEN PERCENT DRY WEIGHT IN PLANTING BEDS, AND 5% ORGANIC MATTER CONTENT IN TURF AREAS, AND A PH FROM 6.0 TO 8.0 OR MATCHING THE PH OF THE ORIGINAL UNDISTURBED SOIL. THE TOPSOIL LAYER SHALL HAVE A MINIMUM DEPTH OF EIGHT INCHES EXCEPT WHERE TREE ROOTS LIMIT THE DEPTH OF INCORPORATION OF AMENDMENTS NEEDED TO MEET THE CRITERIA. SUBSOILS BELOW THE TOPSOIL LAYER SHOULD BE SCARIFIED AT LEAST 4 INCHES WITH SOME INCORPORATION OF THE UPPER MATERIAL TO AVOID STRATIFIED LAYERS, WHERE FEASIBLE.
- PLANTING BEDS MUST BE MULCHED WITH 2 INCHES OF ORGANIC MATERIAL.
- LANDSCAPED AREAS THAT WILL REQUIRE POST CONSTRUCTION SOIL QUALITY AND DEPTH PER BMP T5.13.
 - LAWN = 991 SF
 - PLANER = 1,927 SF

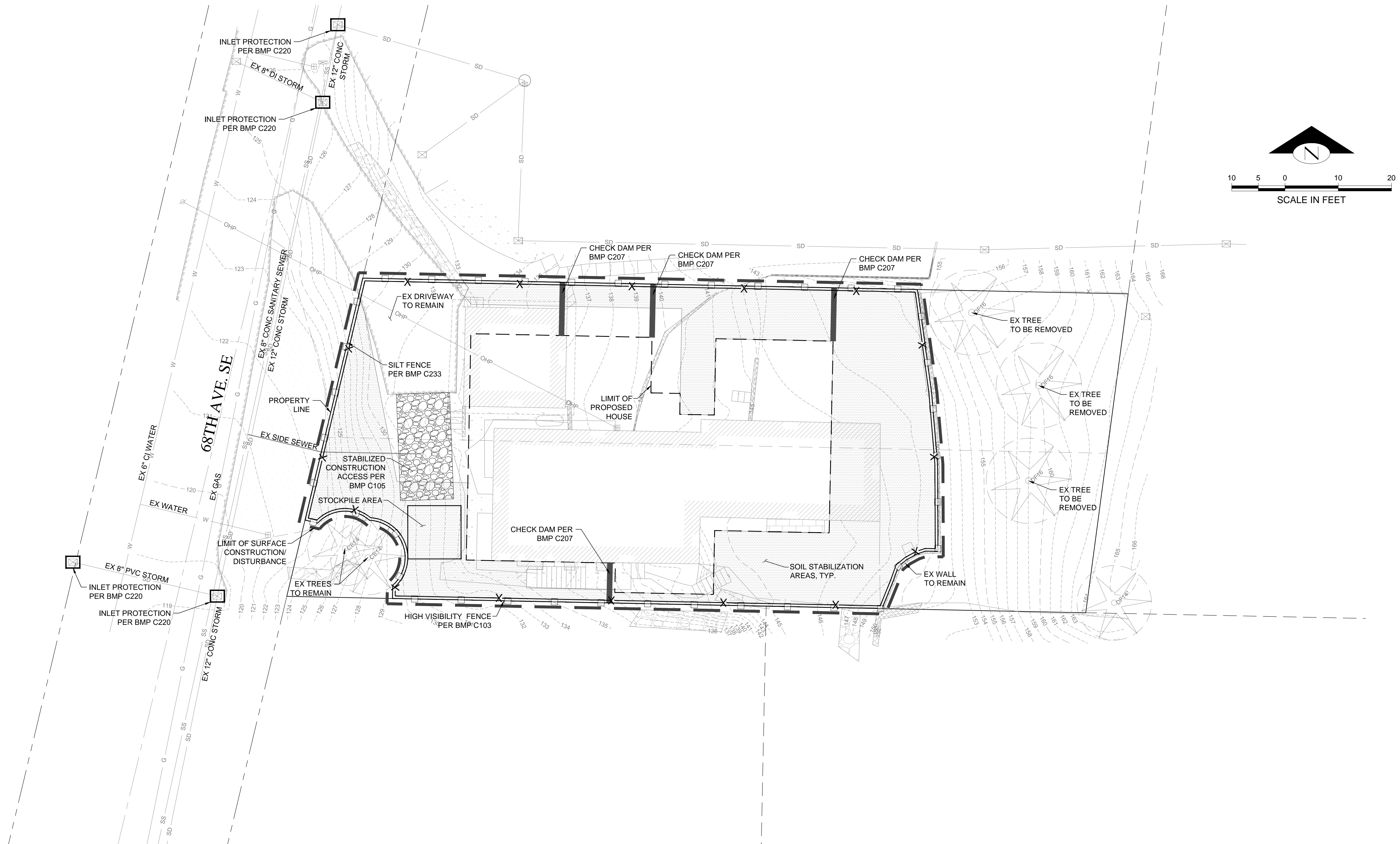

68TH AVE SE
 BUILDING PERMIT SUBMITTAL

BUILDING PERMIT SUBMITTAL
 12.30.2022
 REVISED BUILDING PERMIT SUBMITTAL
 07.14.2023

Jurisdiction Review

Owner Name
 SAM FRANKLIN + JUNE CADENHEAD
 Project Address
 3064 68TH AVE SE
 MERCER ISLAND, WA 98040

Sheet Information	
Job Number	2209
Drawn	RMK
Checked	RMK
Title	

SWPPP Sheet



Green Lake Engineering, LLC
6045 4th Ave. NE
Seattle, WA 98115
Phone: 206-898-4269



68TH AVE SE
BUILDING PERMIT SUBMITTAL

BUILDING PERMIT SUBMITTAL
12.30.2022
REVISED BUILDING PERMIT SUBMITTAL
07.14.2023

Jurisdiction Review

Owner Name
SAM FRANKLIN + JUNE CADENHEAD
Project Address
3064 68TH AVE SE
MERCER ISLAND, WA 98040

Sheet Information
Job Number 2209
Drawn RMK
Checked RMK
Title

SWPPP
DETAILS

Sheet

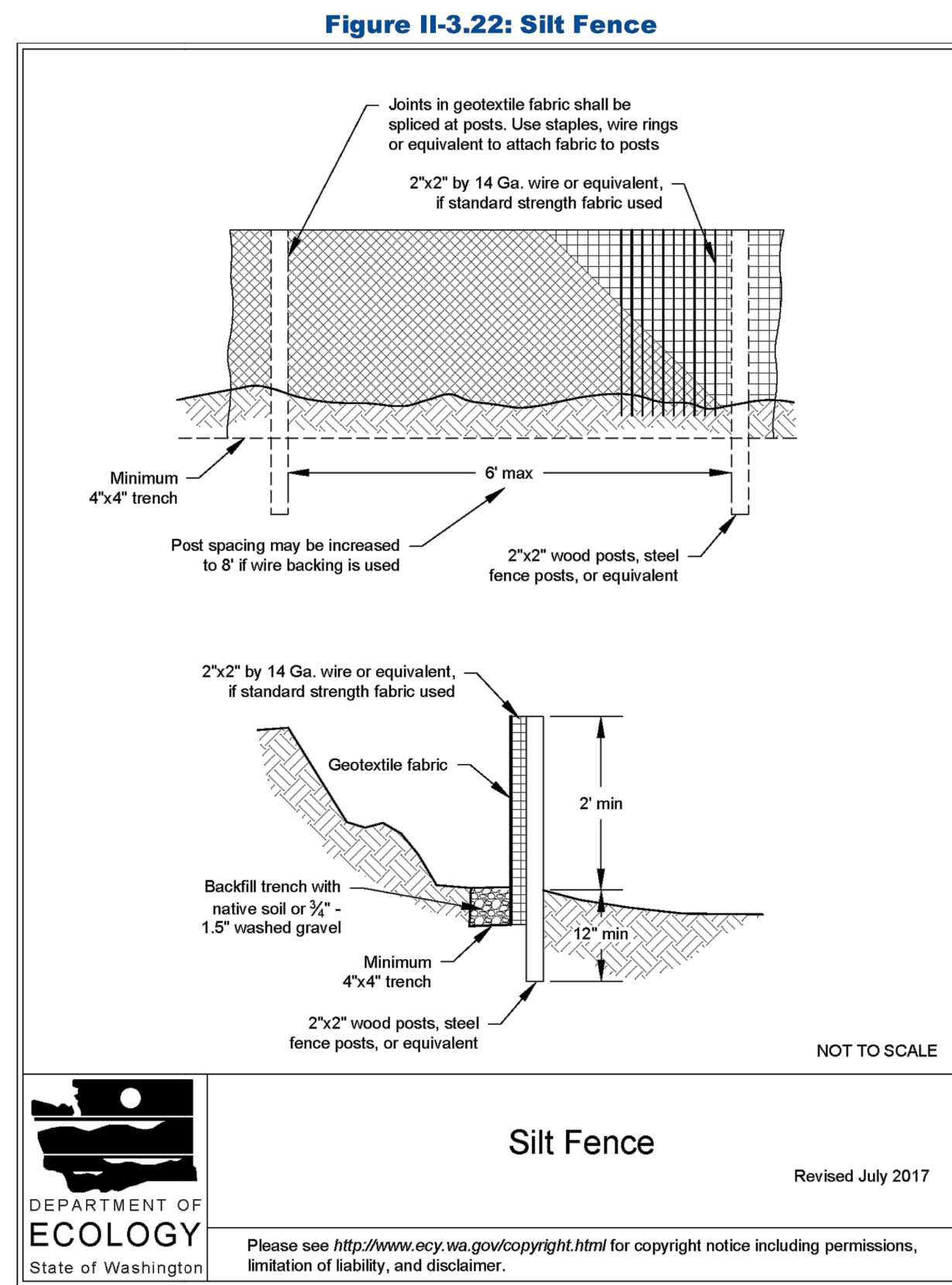

Silt Fence

Revised July 2017



DEPARTMENT OF ECOLOGY
State of Washington
Please see <http://www.ecy.wa.gov/copyright.html> for copyright notice including permissions, limitation of liability, and disclaimer.

2019 Stormwater Management Manual for Western Washington
Volume II - Chapter 3 - Page 371

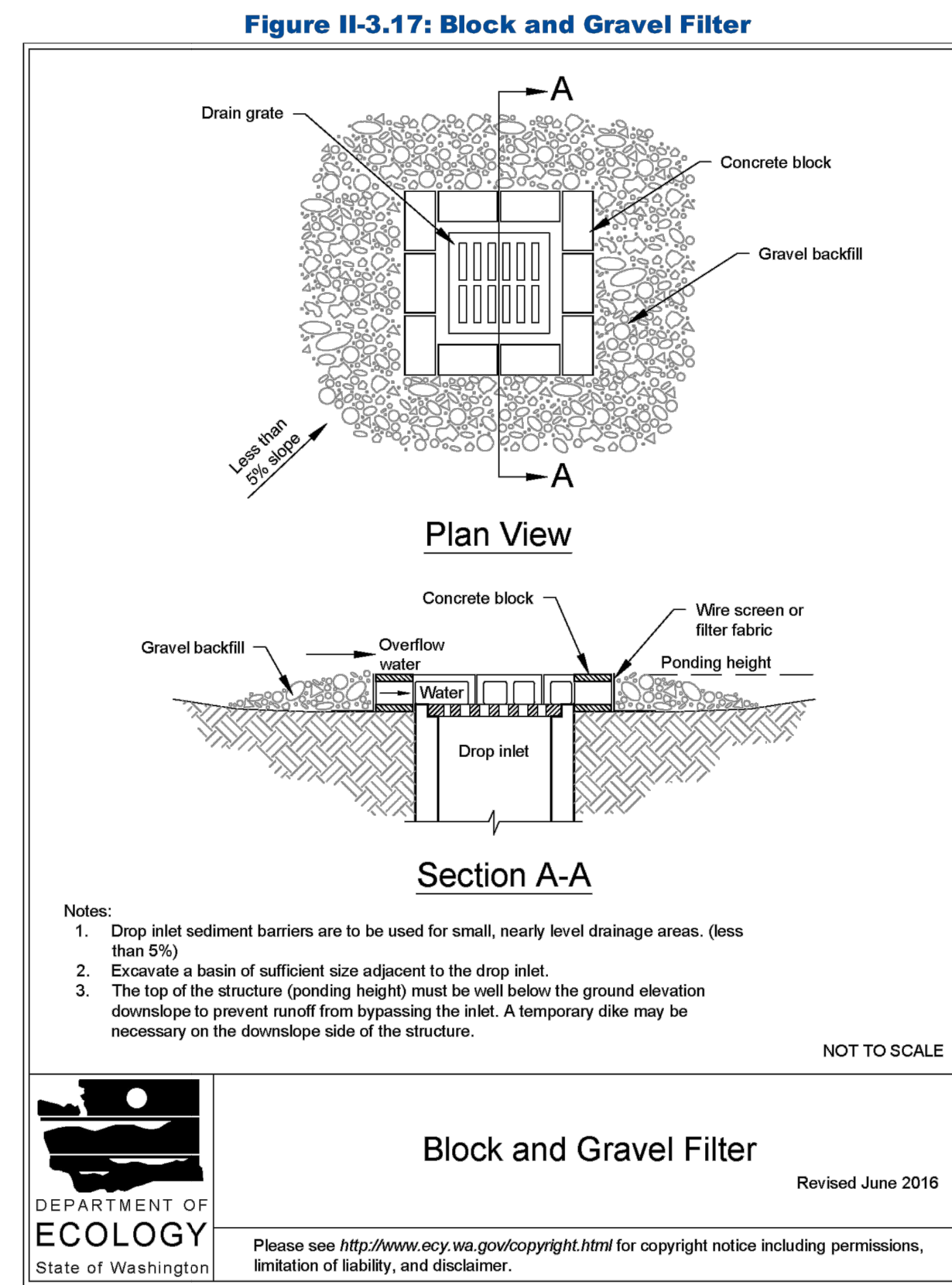

Block and Gravel Filter

Revised June 2016



DEPARTMENT OF ECOLOGY
State of Washington
Please see <http://www.ecy.wa.gov/copyright.html> for copyright notice including permissions, limitation of liability, and disclaimer.

2019 Stormwater Management Manual for Western Washington
Volume II - Chapter 3 - Page 359

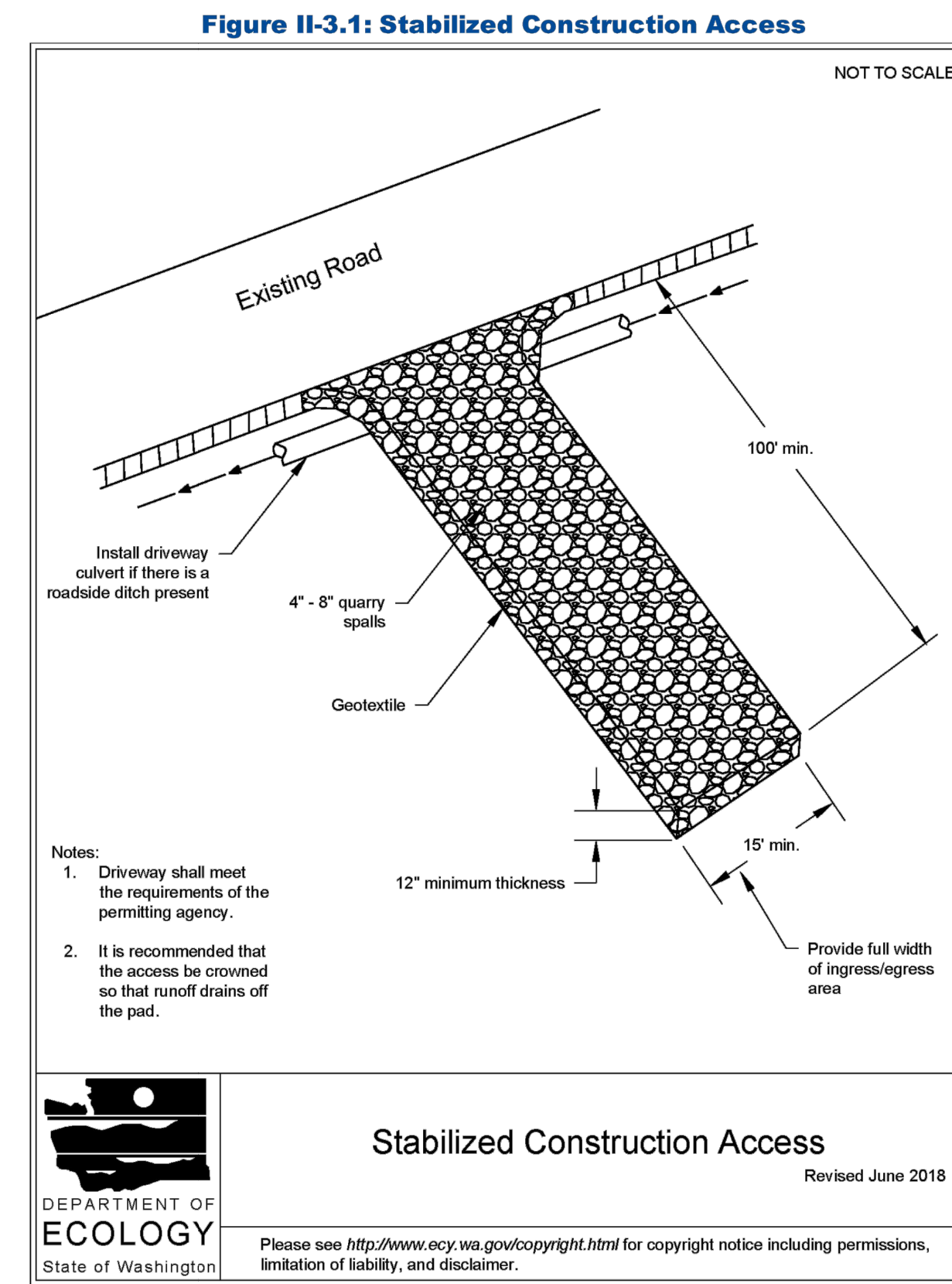

Stabilized Construction Access

Revised June 2018



DEPARTMENT OF ECOLOGY
State of Washington
Please see <http://www.ecy.wa.gov/copyright.html> for copyright notice including permissions, limitation of liability, and disclaimer.

2019 Stormwater Management Manual for Western Washington
Volume II - Chapter 3 - Page 279

DRAWN BY: BILL BERGENS

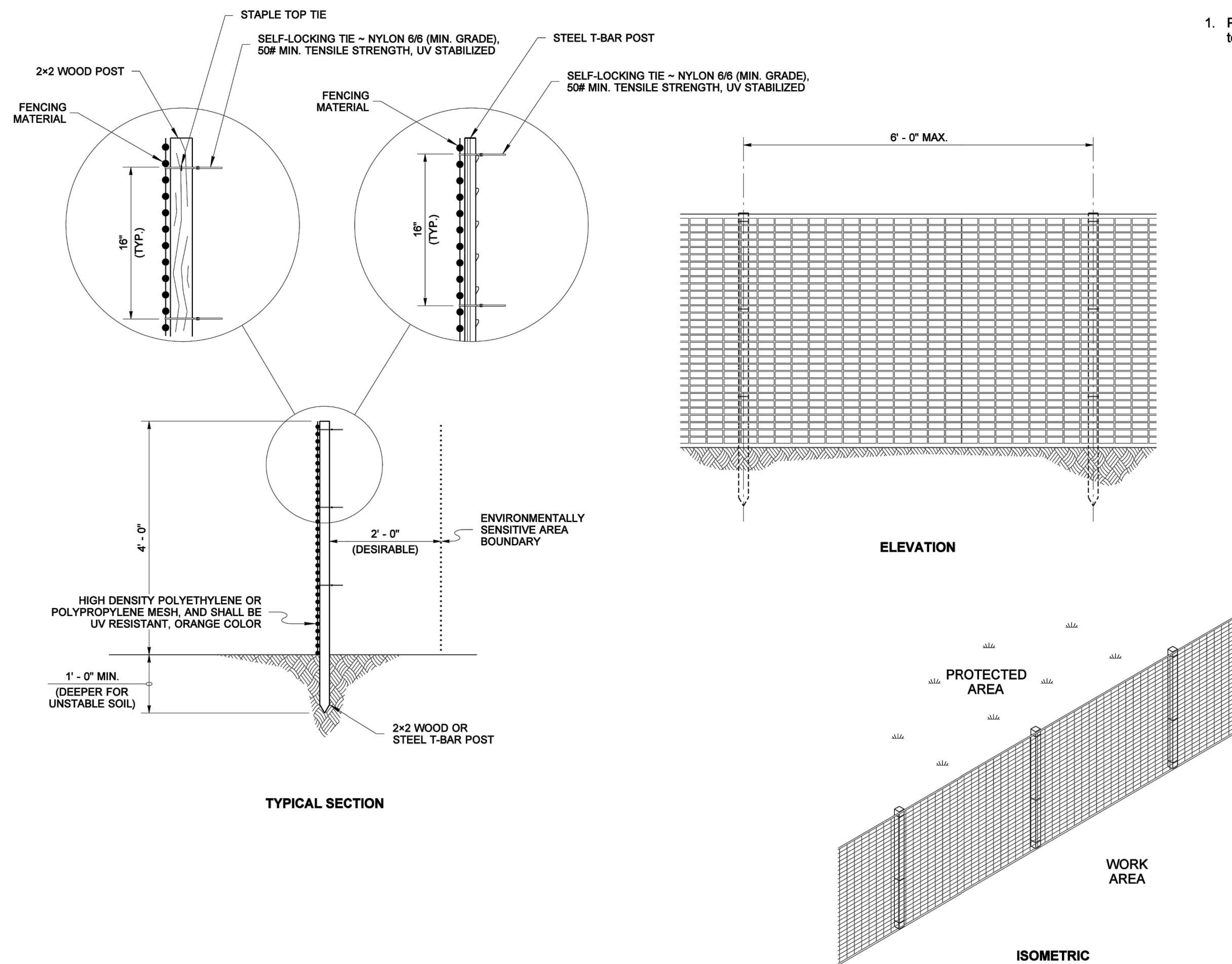

NOTE
1. Post shall have sufficient strength and durability to support the fence through the life of the project.

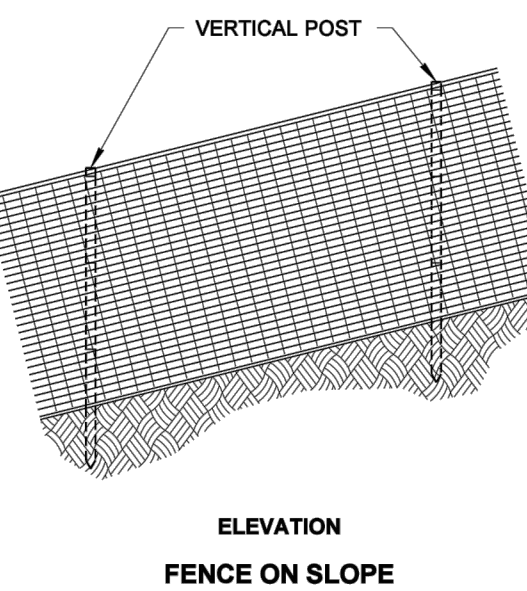

ELEVATION
FENCE ON SLOPE

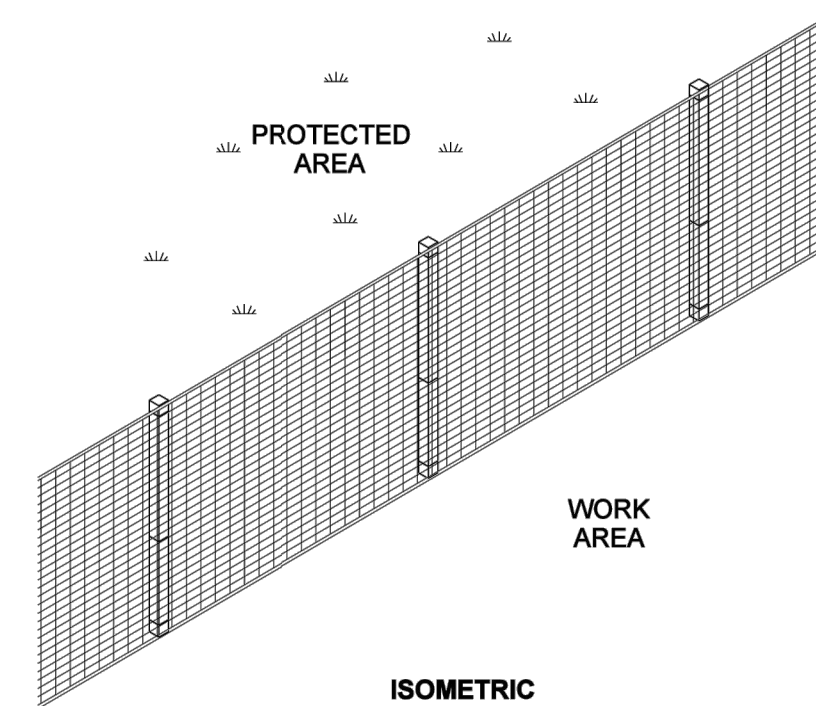

ISOMETRIC



STATE OF WASHINGTON
REGISTERED
LANDSCAPE ARCHITECT
MARK W. MAURER
CERTIFICATE NO. 000598

HIGH VISIBILITY FENCE

STANDARD PLAN I-10.10-01

SHEET 1 OF 1 SHEET

APPROVED FOR PUBLICATION

Pasco Bakotch III 08-11-09

STATE DESIGN ENGINEER DATE
Washington State Department of Transportation

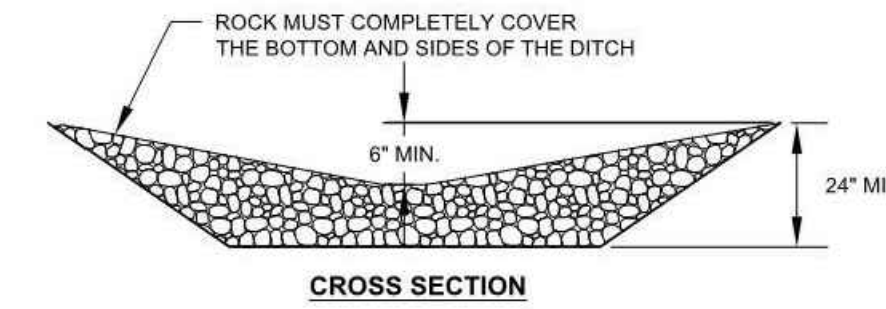

CROSS SECTION

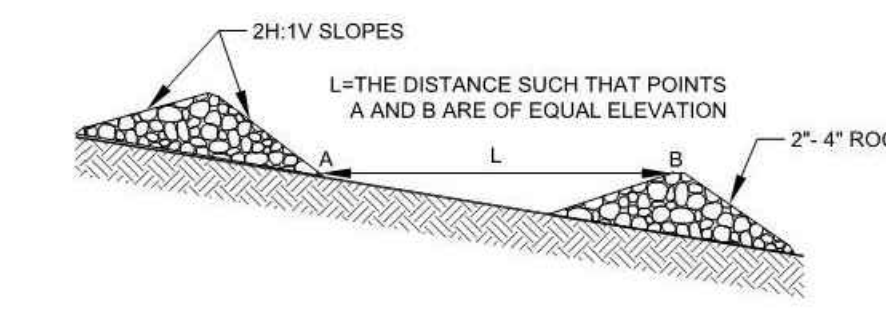

CHECK DAM SPACING

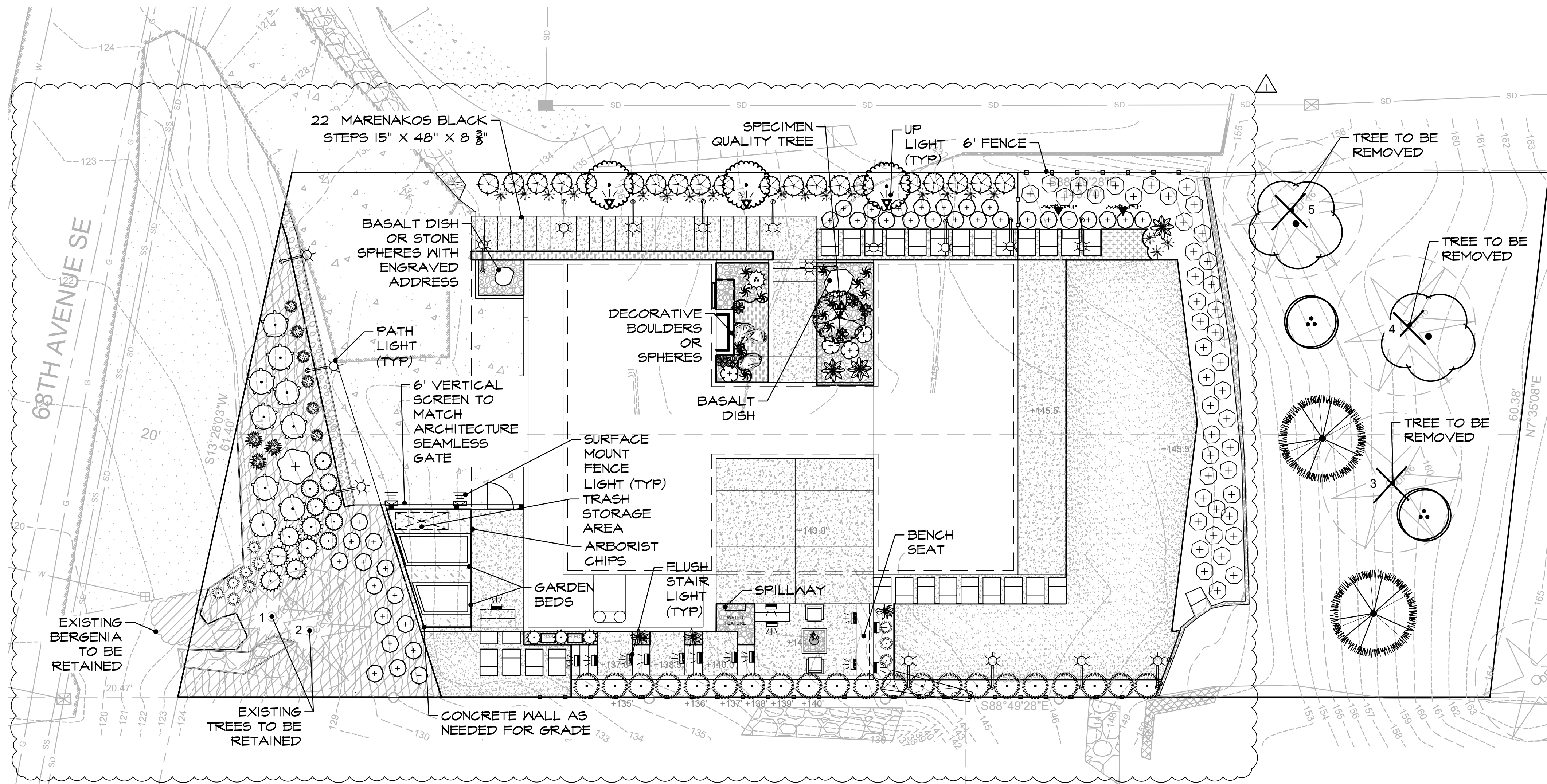

LANDSCAPE NOTES

1. CONTRACTOR SHALL BE RESPONSIBLE FOR FAMILIARIZING THEMSELVES WITH ALL OTHER SITE IMPROVEMENTS AND CONDITIONS PRIOR TO STARTING LANDSCAPE WORK.
2. CONTRACTOR SHALL USE CAUTION WHILE EXCAVATING TO AVOID DISTURBING ANY UTILITIES ENCOUNTERED. CONTRACTOR IS TO PROMPTLY ADVISE OWNER OF ANY DISTURBED UTILITIES. LOCATION SERVICE PHONE 1-800-424-5555.
3. CONTRACTOR SHALL BE RESPONSIBLE FOR COMPUTING SPECIFIC QUANTITIES OF GROUND COVERS AND PLANT MATERIALS UTILIZING ON-CENTER SPACING FOR PLANTS AS STATED ON THE LANDSCAPE PLAN AND MINIMUM PLANTING DISTANCES AS SPECIFIED BELOW IN THESE NOTES.
4. CONTRACTOR SHALL BE RESPONSIBLE FOR PROVIDING THE QUANTITIES OF PLANTS THAT ARE REPRESENTED BY SYMBOLS ON THE DRAWINGS.
5. SUBGRADE IS TO BE WITHIN 1/8" OF ONE FOOT AS PROVIDED BY OTHERS. ALL PLANTING AREAS TO BE CLEARED OF ALL CONSTRUCTION MATERIAL AND ROCKS AND STICKS LARGER THAN 2" DIAMETER.
6. IMPORT 8 INCHES OF COMPOST AMENDED TOPSOIL (25% COMPOST FOR TURF AREAS; 40% COMPOST FOR PLANTING BEDS). SCARIFY SUBSOIL 4" TO INCORPORATE WHERE FEASIBLE WITHOUT IMPACTING TREE ROOTS.
7. 2" DEPTH ORGANIC MULCH IN ALL BED AREAS.
8. ALL PLANT MATERIAL SHALL BE FERTILIZED WITH AGRO TRANSPLANT FERTILIZER 4-2-2 PER MANUFACTURER'S SPECIFICATIONS.
9. ALL PLANT MATERIAL SHALL CONFORM TO AAN STANDARDS FOR NURSERY STOCK, LATEST EDITION. ANY REPLACEMENTS MADE AT ONCE.
 - 9.A. GENERAL: ALL PLANT MATERIAL FURNISHED SHALL BE HEALTHY REPRESENTATIVES, TYPICAL OF THEIR SPECIES OF VARIETY AND SHALL HAVE A NORMAL GROWTH HABIT. THEY SHALL BE FULL, WELL BRANCHED, WELL PROPORTIONED, AND HAVE A VIGOROUS, WELL DEVELOPED ROOT SYSTEM. ALL PLANTS SHALL BE HARDY UNDER CLIMATIC CONDITIONS SIMILAR TO THOSE IN THE LOCALITY OF THE PROJECT.
 - 9.B. TREES, SHRUBS, AND GROUND COVER: QUANTITIES, SPECIES, AND VARIETIES, SIZES AND CONDITIONS AS SHOWN ON THE PLANTING PLAN. PLANTS TO BE HEALTHY, VIGOROUS, WELL FOLIATED WHEN IN LEAF. FREE OF DISEASE, INJURY, INSECTS, DECAY, HARMFUL DEFECTS, AND ALL WEEDS. NO SUBSTITUTIONS SHALL BE MADE WITHOUT WRITTEN APPROVAL FROM LANDSCAPE ARCHITECT OR OWNER.
10. ALUMINUM EDGING, PERMALOC OR APPROVED EQUAL, TO BE INSTALLED BETWEEN BARK AND COBBLE.

IRRIGATION: A TEMPORARY IRRIGATION SYSTEM IS REQUIRED FOR ALL REPLACEMENT TREES. EACH TREE TO BE IRRIGATED WITH DRIP BUBBLERS FOR A MINIMUM OF 5 YEARS.
 AFTER INITIAL PLANTING, DRIP SYSTEM SHOULD BE SCHEDULED TO RUN THREE DAYS A WEEK FOR 30 MINUTES MONITOR SOIL MOISTURE DAILY.
 AFTER ONE GROWING SEASON, SCHEDULE IRRIGATION TO RUN ONE DAY A WEEK DURING APRIL, MAY, SEPTEMBER AND OCTOBER.
 TWICE A WEEK FROM JUNE THROUGH AUGUST.
 SET THE RUN TIME BETWEEN 45-60 MINUTES.
 AFTER WATERING, CHECK THE SOIL MOISTURE AT THE ROOT (AT LEAST 6 INCHES DEEP) AND ADJUST THE RUN TIME IF NEEDED.
 -CHECK THE DRIP SYSTEM TWICE A MONTH TO ENSURE THE SYSTEM IS RUNNING PROPERLY.
 -HAND CLEAR AND GRUB A 3' DIAMETER RING OF ALL GRASS, WEEDS AND INVASIVE SPECIES AROUND EACH REPLACEMENT TREE AND INSTALL 3" DEPTH OF ARBORIST CHIP MULCH IN PLANTING RING.

TREE RETENTION REQUIREMENTS
 MINIMUM 30% LARGE TREES RETAINED
 TOTAL LARGE TREES ON SITE: 5
 TREES TO BE REMOVED: 3 (TREE #3, #4, #5)
 TREES TO TO BE RETAINED: 2 (TREE #1, #2)= 40%

TREE REPLACEMENT CALCULATIONS
 LARGE TREES TO BE REMOVED: 3 (TREE #3, #4, #5)
 REPLACEMENT REQUIRED 2:1 RATIO:
 6 REPLACEMENT TREES REQUIRED- 6'TALL MIN
 CONIFERS #1.5" CAL DECIDUOUS TREES
 REPLACEMENTS PROVIDED: 6
 2-ACER CIRCINATUM
 2-CORNUS NUTTALLII

Root of Design
 206.441.4545
 2020 Maitby Rd
 Ste 7, FMB 370
 Bothell, WA 98021
 www.rootofdesign.com

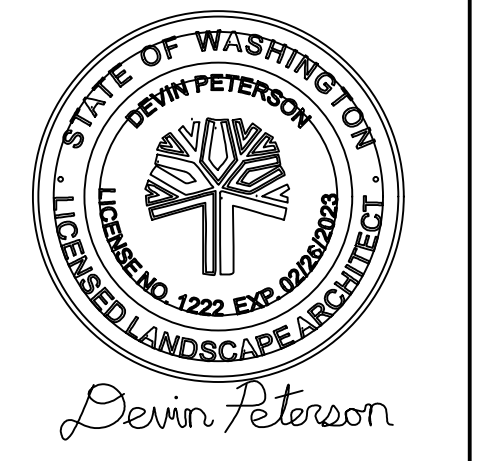

PROJECT TITLE

LANDSCAPE PLAN

3064 68TH AVE SE MERCER ISLAND, WA

DRAWN	DATE
KL	12.22.22
REVISED	DATE
KL	05.01.23
KL	07.05.23

1/8" = 1'-0"

L1

PLANT SCHEDULE *

TREES	BOTANICAL / COMMON NAME	SIZE	QTY
	Acer circinatum / Vine Maple Replacement Tree	1.5" Cal, 6' Ht min.	2
	Acer palmatum 'Sango-kaku' / Coral Bark Japanese Maple	2"-2.5" Cal B4B	1
	Cornus nuttallii / Pacific Dogwood Replacement Tree	1.5" Cal, 6' Ht min.	2
	Pinus contorta / Shore Pine Replacement Tree	6'-7' Ht.	2
	Populus tremula 'Erecta' / Swedish Columnar Aspen	1.75" Cal.	3

GROUND COVERS	BOTANICAL / COMMON NAME	SIZE	SPACING	QTY
	Ophiopogon japonicus 'Nanus' / Dwarf Mondo Grass	4"pot	15" o.c.	36
	Rubus calycinoides 'Emerald Carpet' / Creeping Raspberry	4"pot	24" o.c.	116
	Sagina subulata / Irish Moss	4"pot	18" o.c.	50
	Sedum rupestre 'Angelina' / Yellow Stonecrop	4"pot	18" o.c.	7
	Turf Sod / Drought Tolerant Fescue Blend	sod		491 sf

SITE	BOTANICAL / COMMON NAME	SIZE	SPACING	QTY
	Arborist Chips 3" Depth	N/A		50 sf
	Black Polished Mexican Beach Pebbles 1"-2"	N/A		112 sf
	Cobble 1"-3"	N/A		43 sf

PLANT SCHEDULE *

SHRUBS	BOTANICAL / COMMON NAME	SIZE	QTY
	Azalea x 'Sumpo White' / Gumpo White Satsuki Azalea	1 gal	4
	Berberis thunbergii 'Crimson Pygmy' / Crimson Pygmy Barberry	5 gal	6
	Calamagrostis x acutiflora 'Karl Foerster' / Feather Reed Grass	1 gal	6
	Camellia sasanqua 'Yuletide' / Yuletide Camellia	5 gal, Espaller	2
	Carex oshimensis 'CaritO!' / EverColor® Everest Japanese Sedge	1 gal	19
	Carex oshimensis 'Everillo' / Everillo Japanese Sedge	1 gal	13
	Carex testacea / Orange Sedge	1 gal	10
	Cholsya ternata 'Sundance' / Sundance Mexican Mock Orange	3 gal	9
	Cotinus coggygria 'Royal Purple' / Royal Purple Smoke Tree	5 gal	1
	Gaultheria shallon / Salal	1 gal	44
	Ilex crenata 'Sky Pencil' / Sky Pencil Japanese Holly	20" Ht min	3
	Lonicera pileata 'Moss Green' / Moss Green Honeysuckle	2 gal	7
	Mahonia eurybracteata 'Soft Caress' / Mahonia Soft Caress	2 gal	3
	Miscanthus sinensis 'Purpurescens' / Purple Eulalia Grass	2 gal	3
	Phormium tenax / New Zealand Flax	2 gal	3
	Pinus mugo 'Slowmound' / Slowmound Mugo Pine	2 gal	1
	Polystichum polyblepharum / Japanese Tassel Fern	1 gal	6
	Prunus laurocerasus 'Mount Vernon' / Mount Vernon Laurel	2 gal	37
	Taxus x media 'H.M. Eddie' / H.M Eddie Yew	3'-5' Ht	20
	Thuja occidentalis 'Smaragd' / Emerald Green Arborvitae	8'-9' Ht.	21

LIGHTING SCHEDULE *

SYMBOL	MANUFACTURER/MODEL/DESCRIPTION	QTY
	FX Luminaire M-PL Die-cast aluminum path light with powder-coated finish. 2.2in. W x 7.4in. H x 21.3in. H. Order code: M-PL, Aluminum, (FB) Flat Black, Deck Mount Lamp: M-PL-ILED, 2W/2.4VA, 2700K, Beamspread: Flood	17
	UP LIGHT Lamp: LED	4
	FX Luminaire RH Recessed wall/step light. Order code: RH, Aluminum, (FB) Flat Black, Direct Mount Lamp: RH-ILED, 1.9W/2.2VA, 2700K, Beamspread: Wide	15
	FX Luminaire H5 H5 floor-grazing, recessed hardscape light. 8in. W x 2.3in. H x 4.5in. D. Order code: H5, Aluminum, (FB) Flat Black Lamp: H5-2LED, 3.5W/3.8VA, 2700K, Beamspread: Wide	2

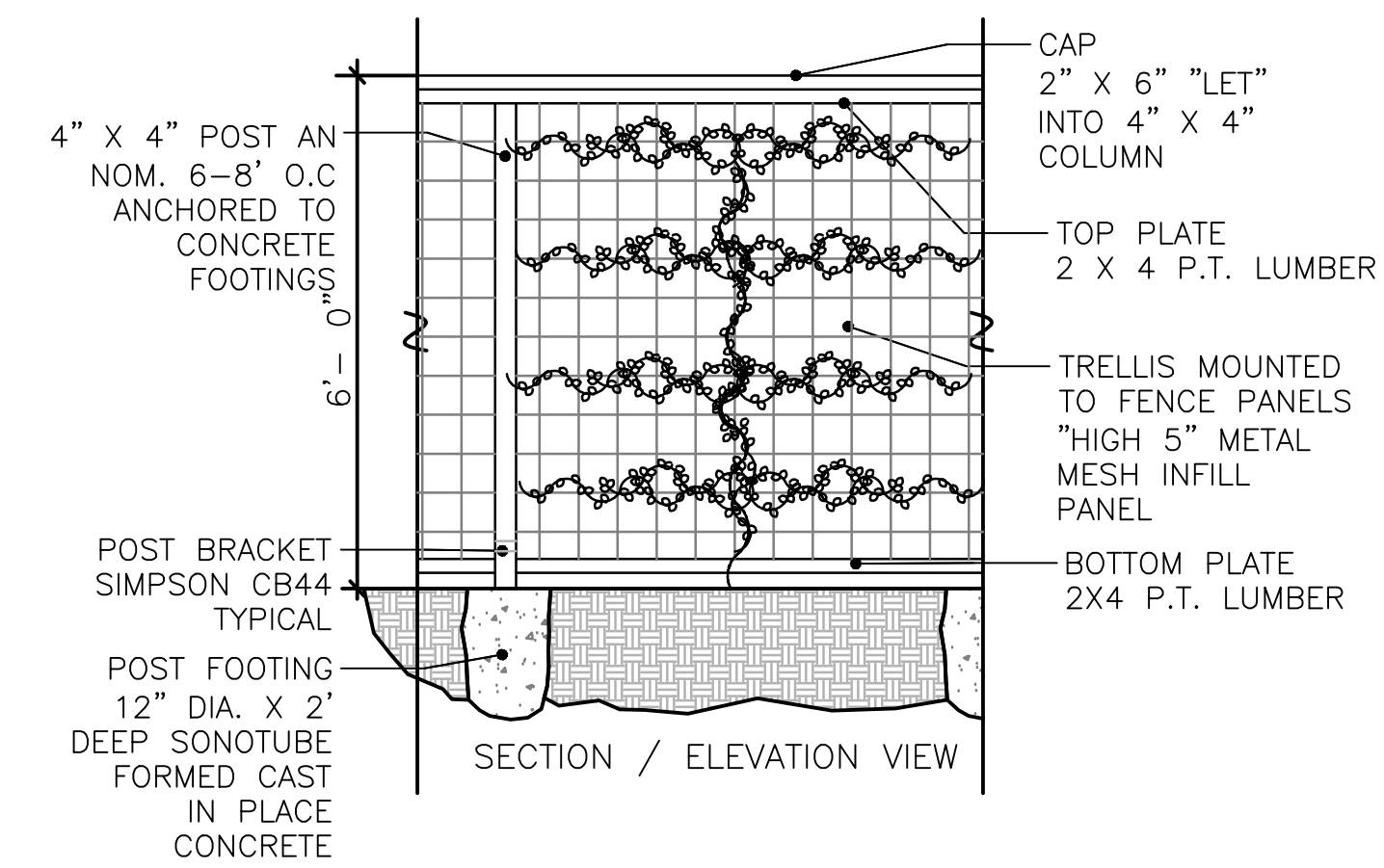

5 ESPALIER ON FENCE DETAIL
NTS

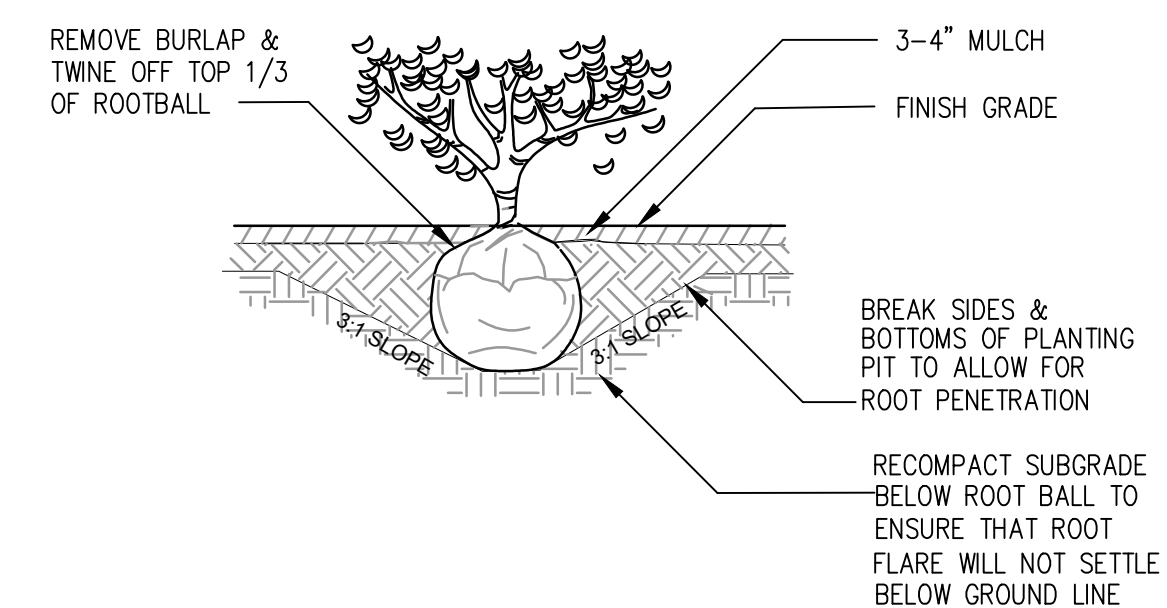

4 TYPICAL SHRUB PLANTING DETAIL
NTS

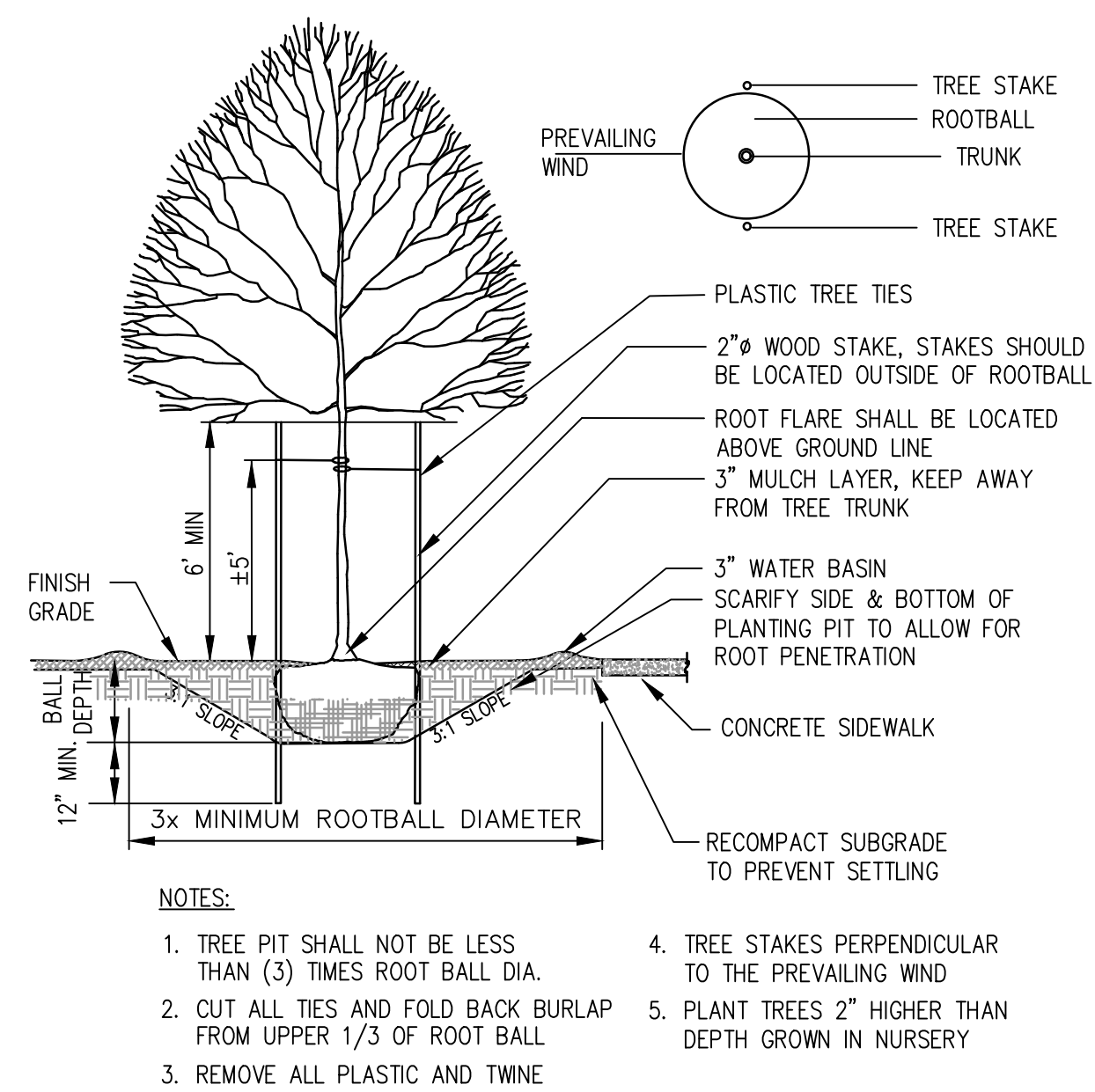

1 TYPICAL DECIDUOUS TREE PLANTING DETAIL
NTS

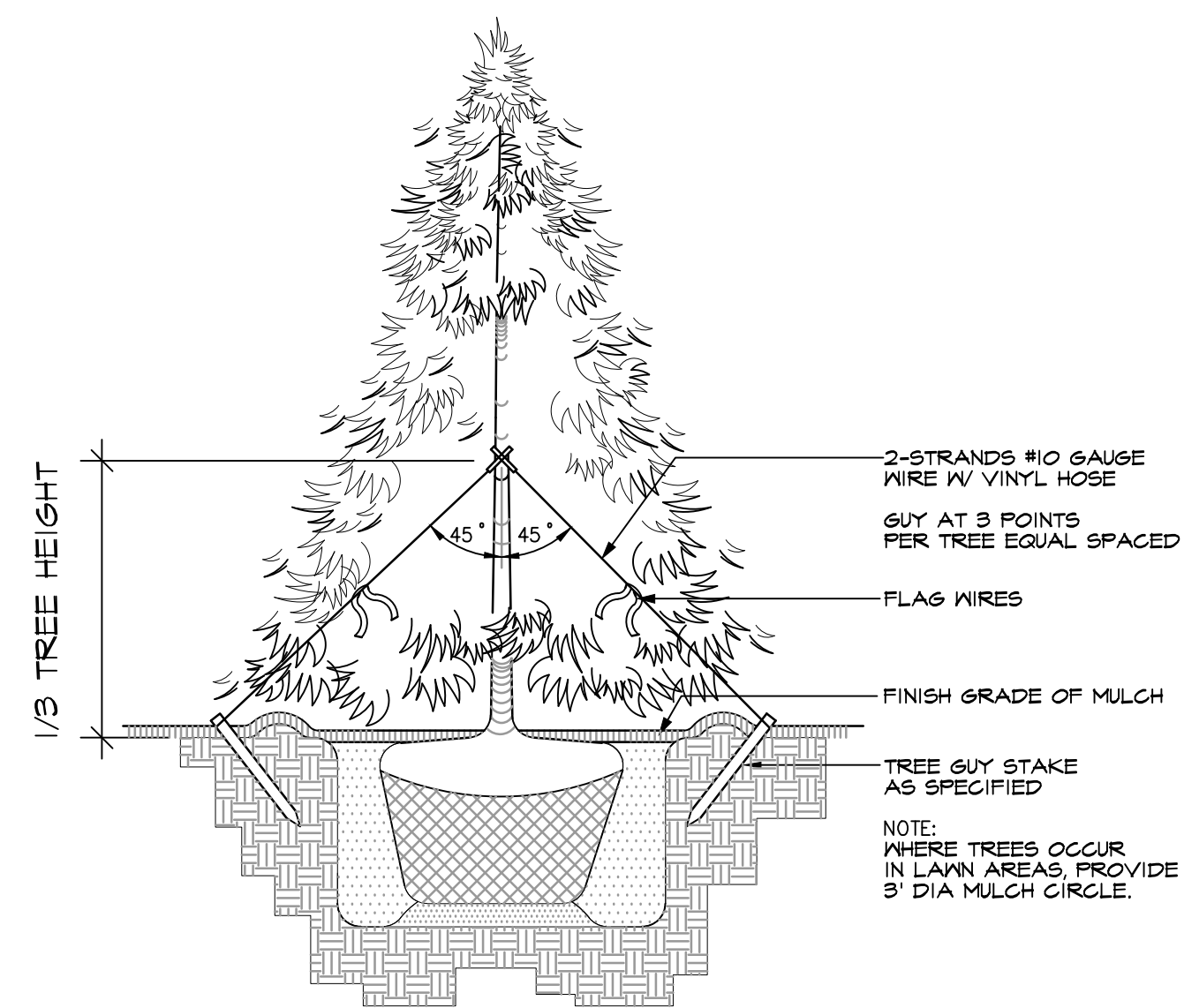

2 TYPICAL EVERGREEN TREE PLANTING DETAIL
NTS

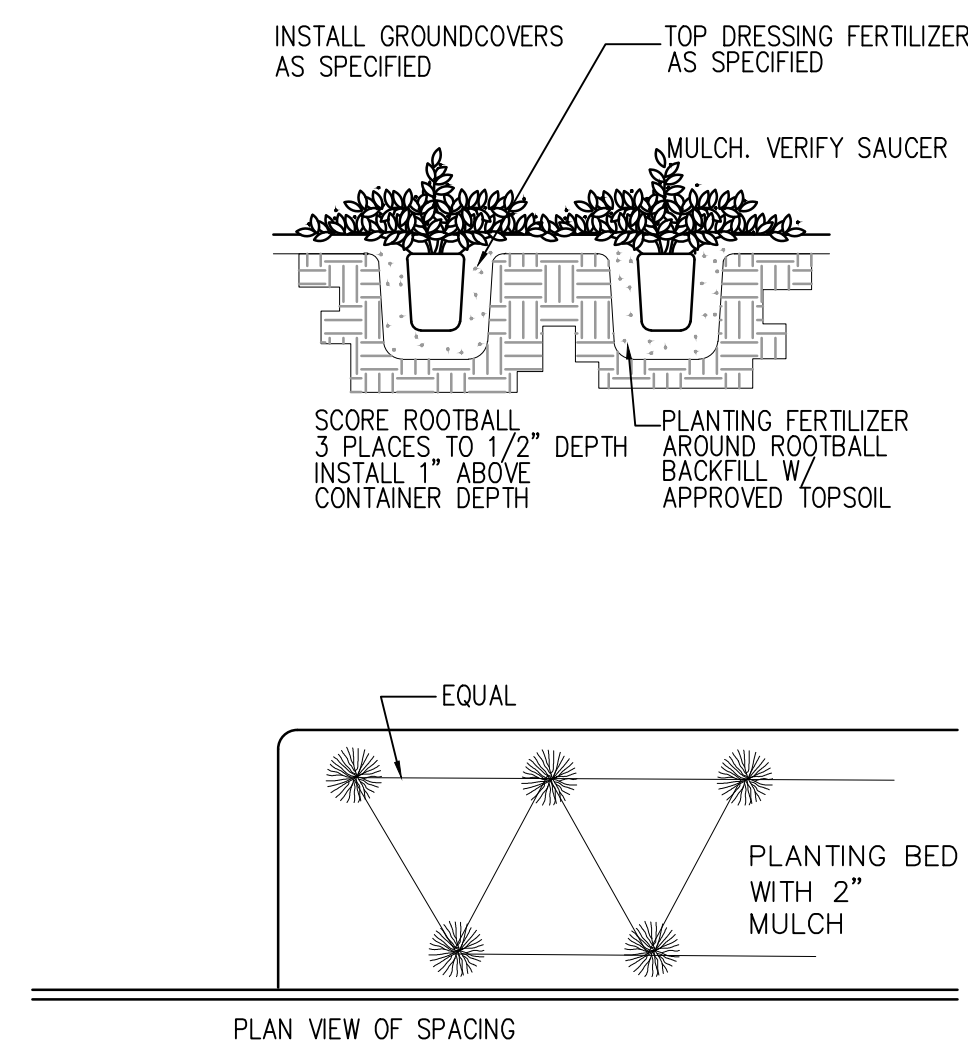

3 TYPICAL GROUNDCOVER PLANTING DETAIL
NTS

Root of Design
206.441.4545
2020 Maitby Rd
Ste 7, FMB 370
Bothell, WA 98021
www.rootofdesign.com



PROJECT TITLE

LANDSCAPE PLAN

3064 68TH AVE SE MERCER ISLAND, WA

DRAWN DATE 12.22.22

REVISED DATE 05.01.23
DATE 07.05.23

NTS

L2

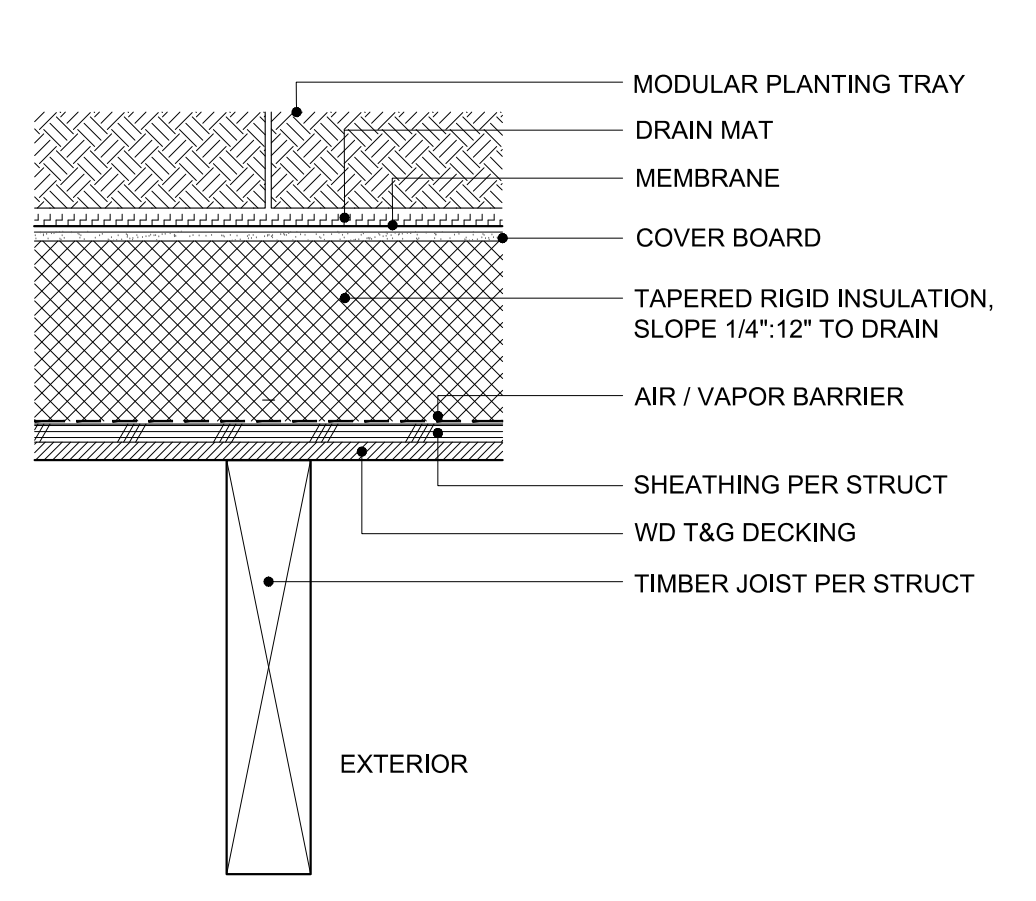

R5 ROOF - WEST OVERHANG
1 1/2"=1'-0"

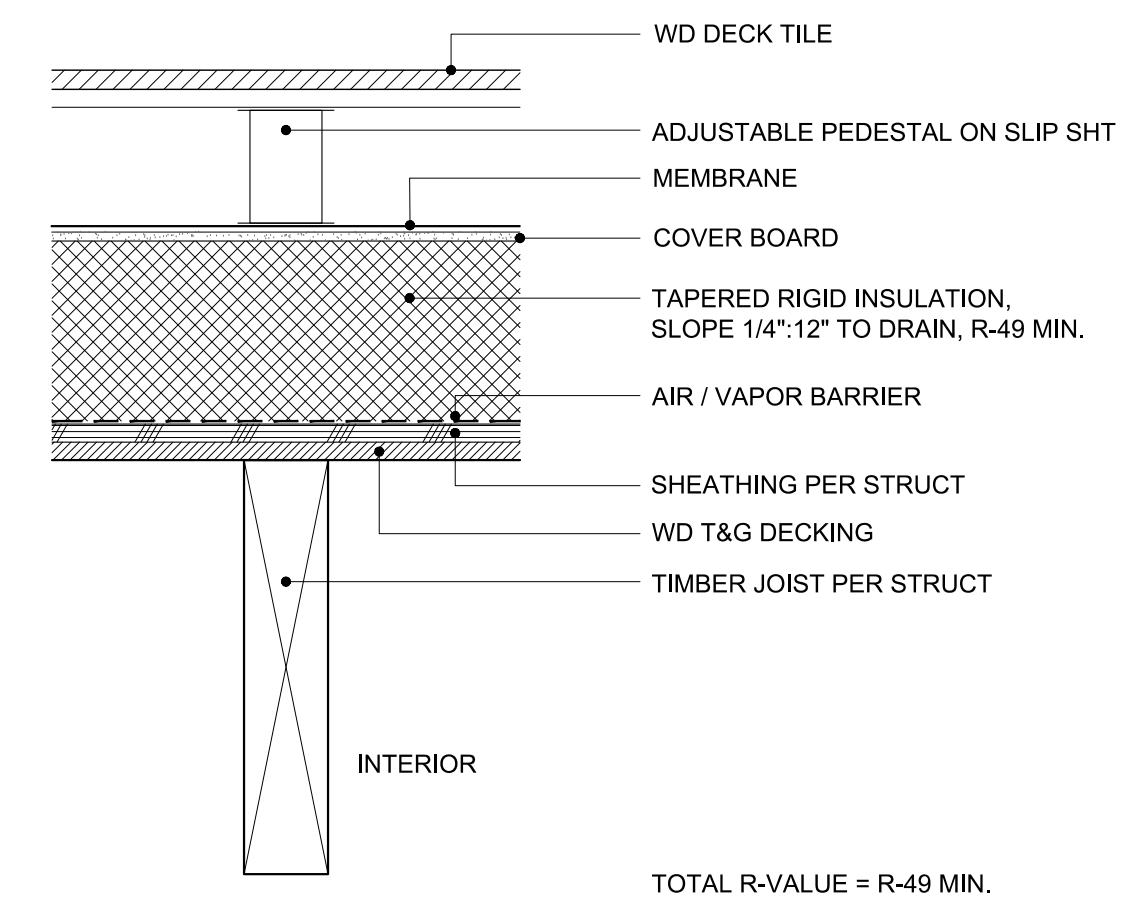

R4 ROOF - WOOD DECK OVER HEATED SPACE
1 1/2"=1'-0"

TOTAL R-VALUE = R-49 MIN.

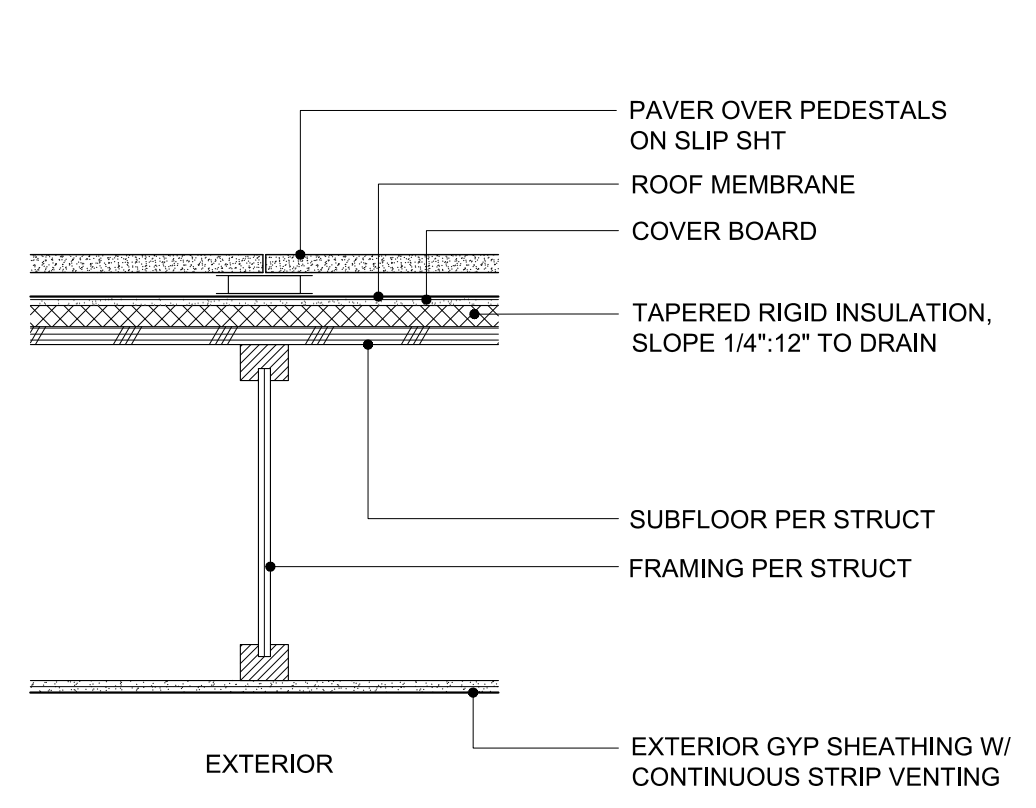

R3 ROOF - LEVEL 1 DECK & SOFFIT
1 1/2"=1'-0"

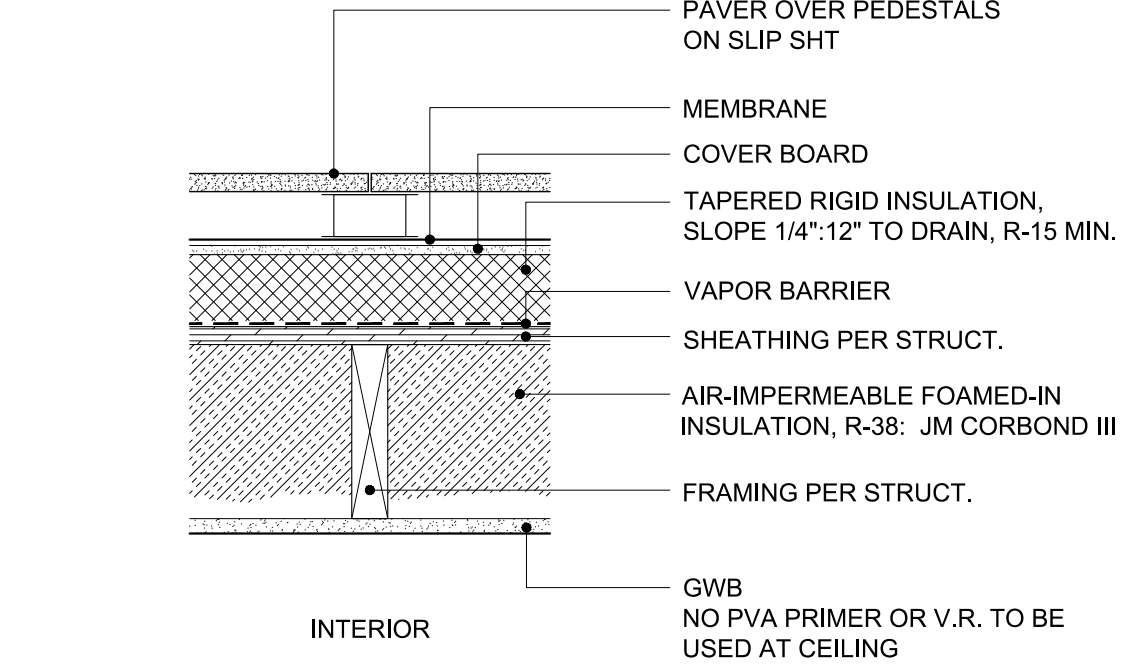

R2 ROOF - COURTYARD
1 1/2"=1'-0"

NOTE:
1. A COPY OF THE ICC-ES REPORT FOR THE INSULATION PRODUCT MUST BE PROVIDED ON SITE FOR THE FIELD INSPECTOR.
2. THE APPLIED FOAMED-IN PRODUCT MUST BE INSTALLED BY A CERTIFIED INSTALLER IN ACCORDANCE WITH THE MANUFACTURER'S INSTRUCTIONS.
TOTAL R-VALUE = R-53 MIN.

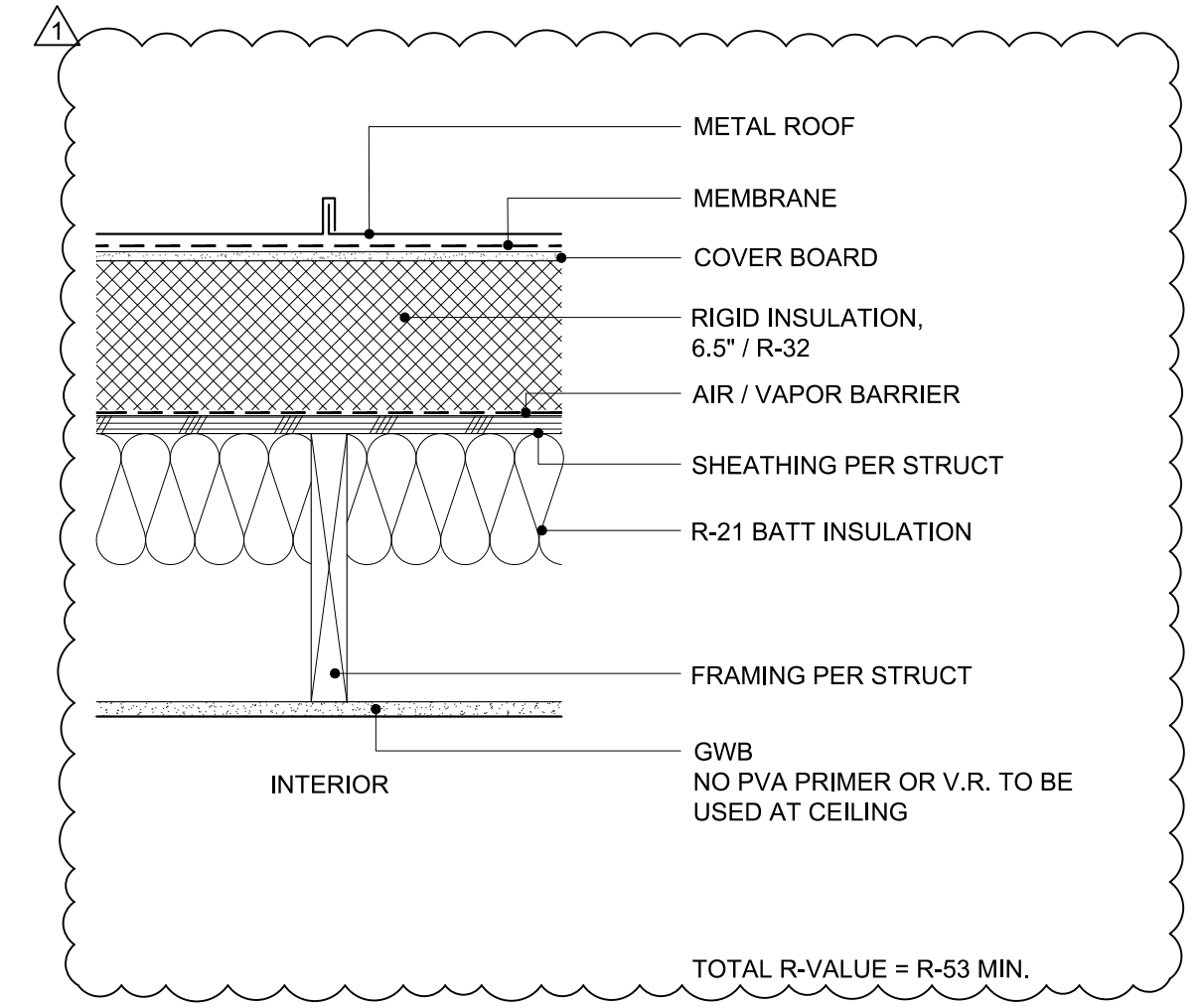

R1 ROOF - TYPICAL
1 1/2"=1'-0"

TOTAL R-VALUE = R-53 MIN.

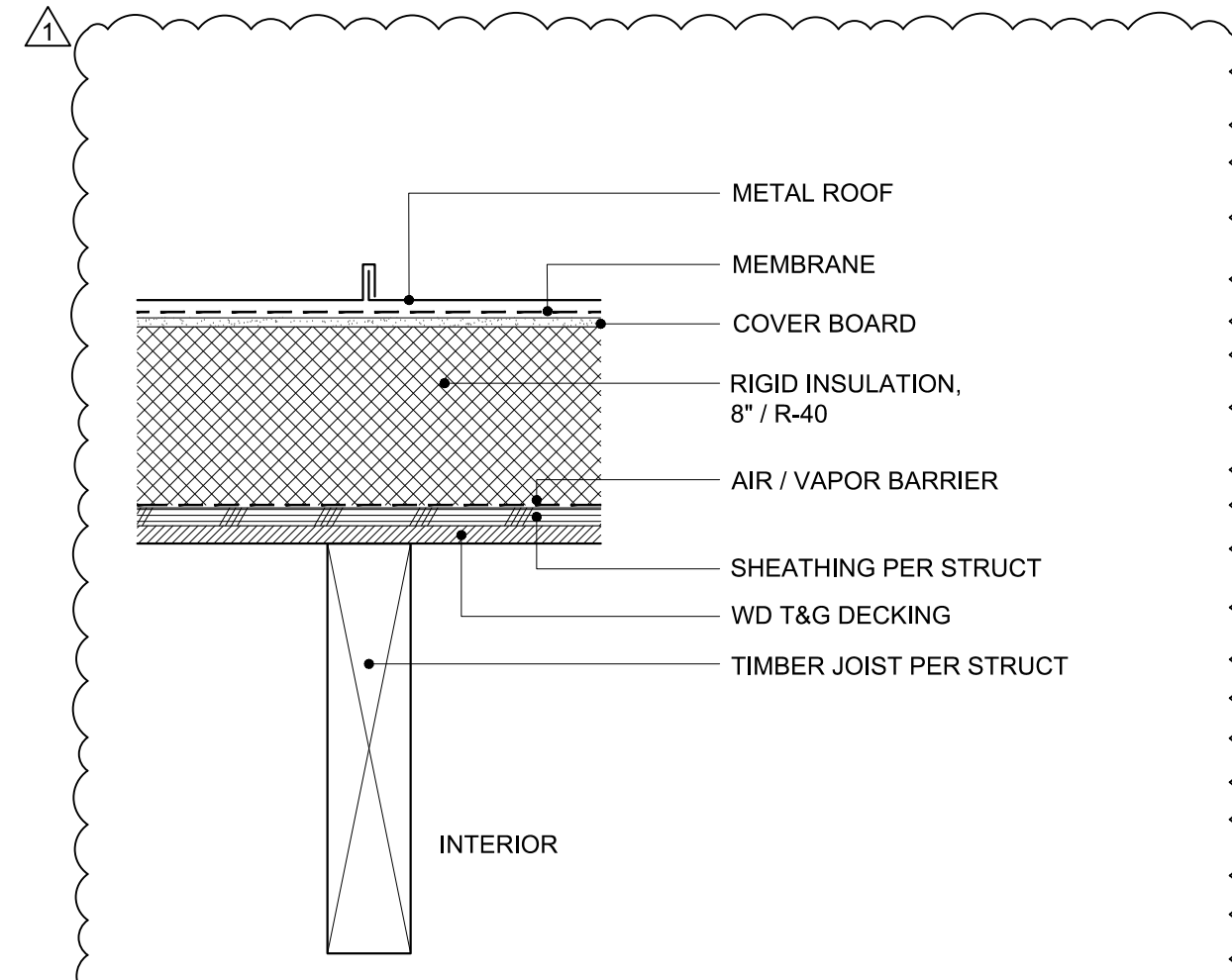

R6 ROOF - EXPOSED JOISTS
1 1/2"=1'-0"

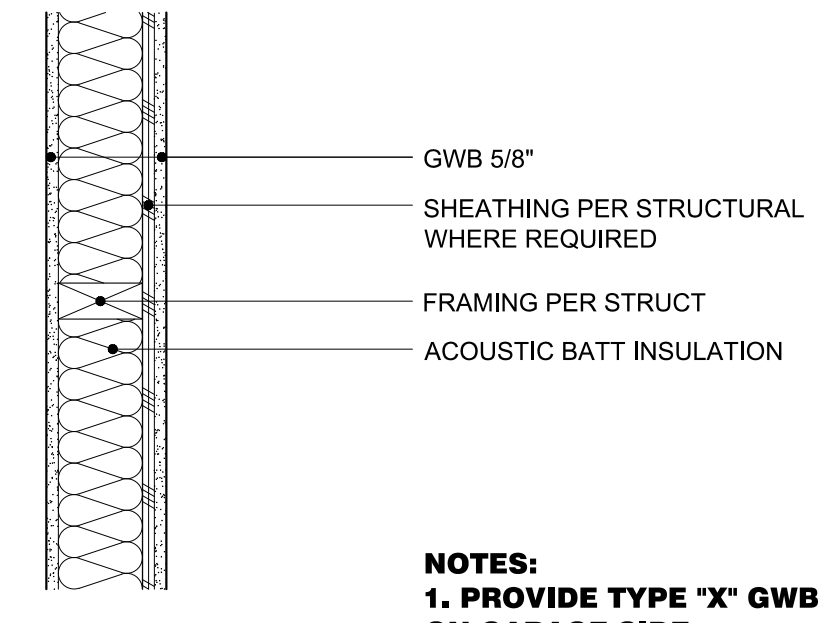
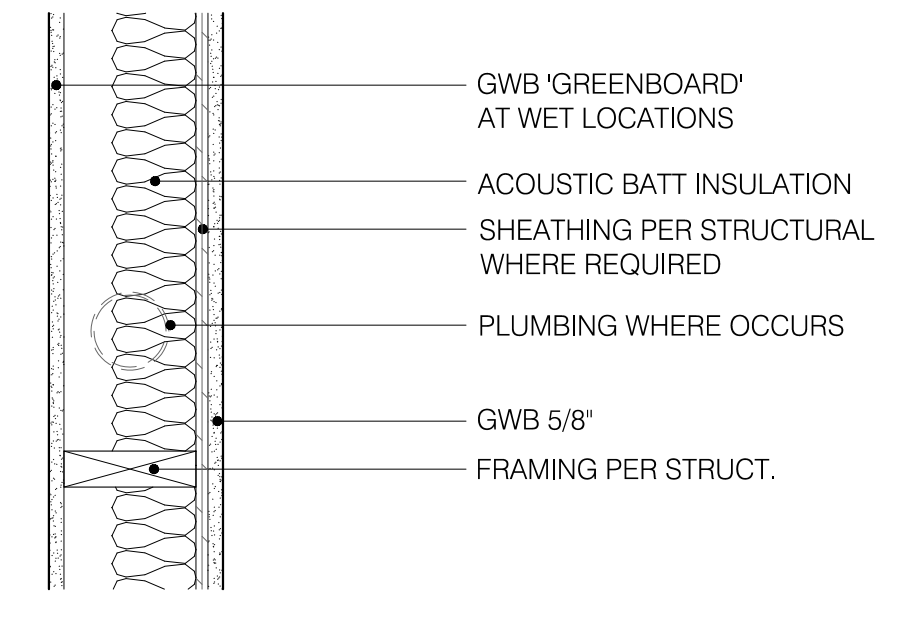

NOTES:
1. PROVIDE TYPE "X" GWB ON GARAGE SIDE
2. PROVIDE 1/2" RESILIENT CHANNEL ON ADU SIDE

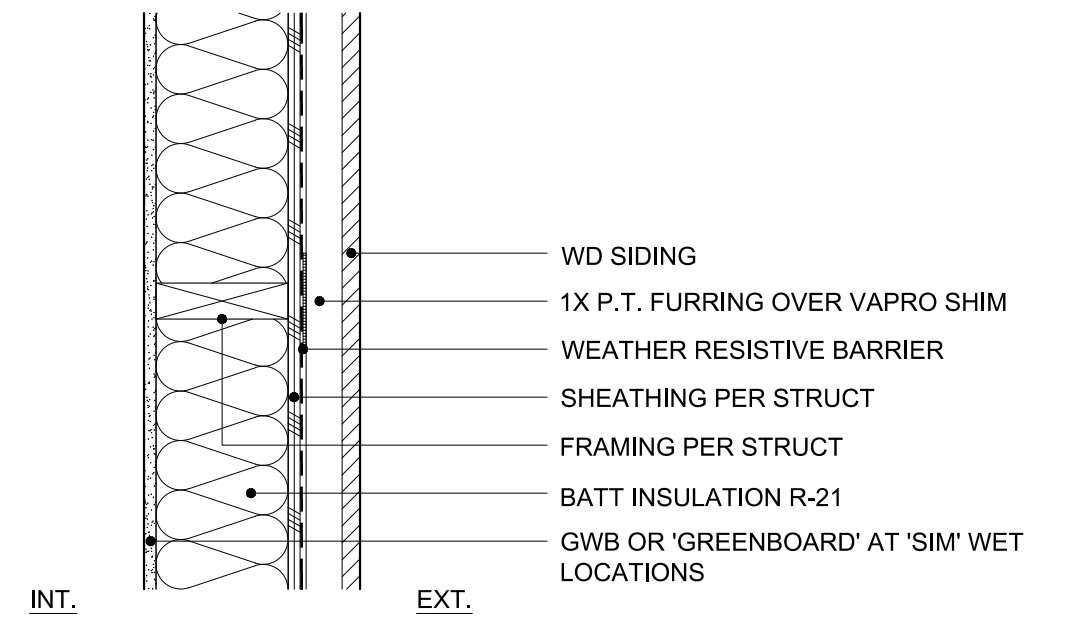

TOTAL R-VALUE = R-21

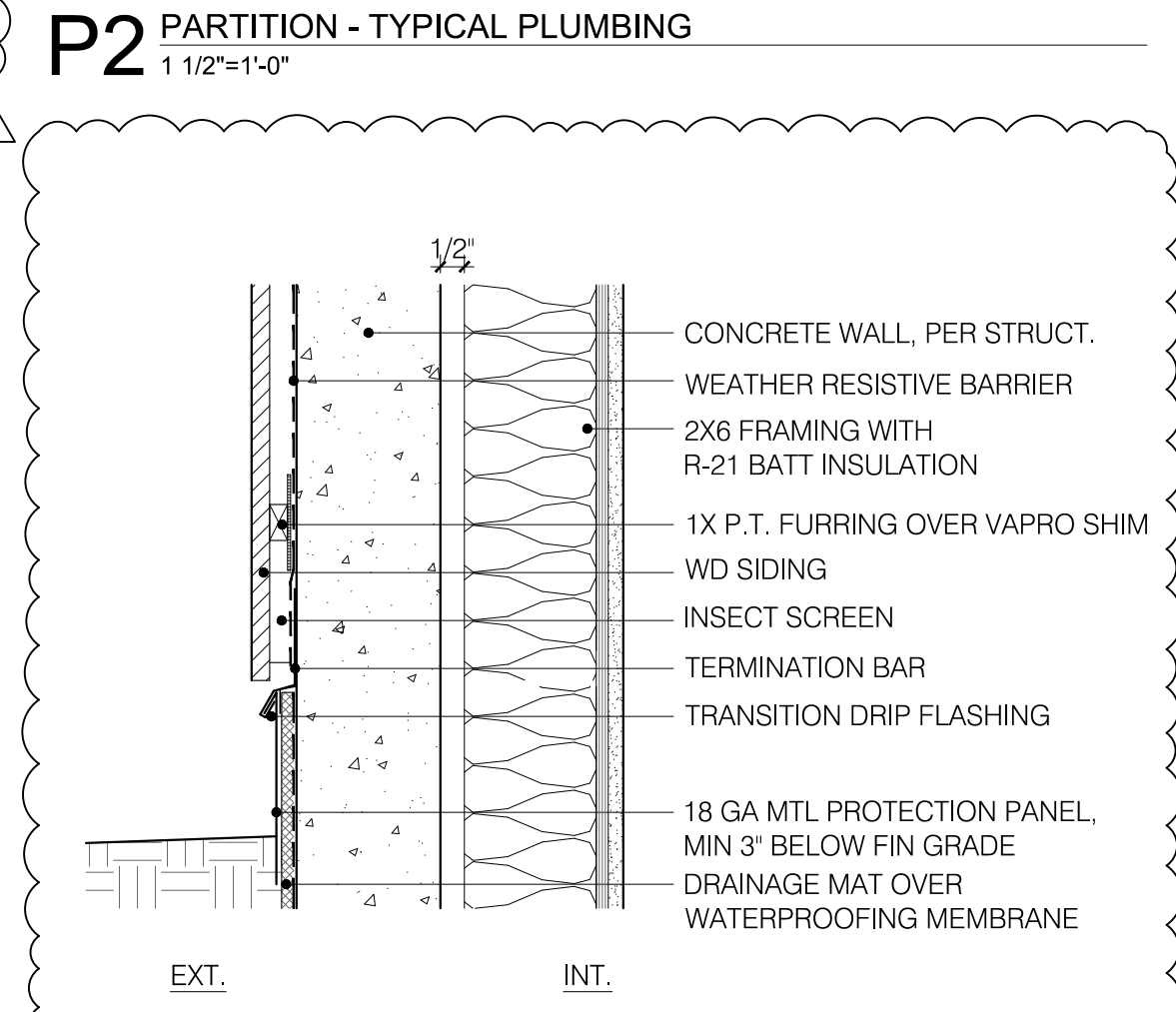

P2 PARTITION - TYPICAL PLUMBING
1 1/2"=1'-0"

TOTAL R-VALUE = R10 MIN. C.I.

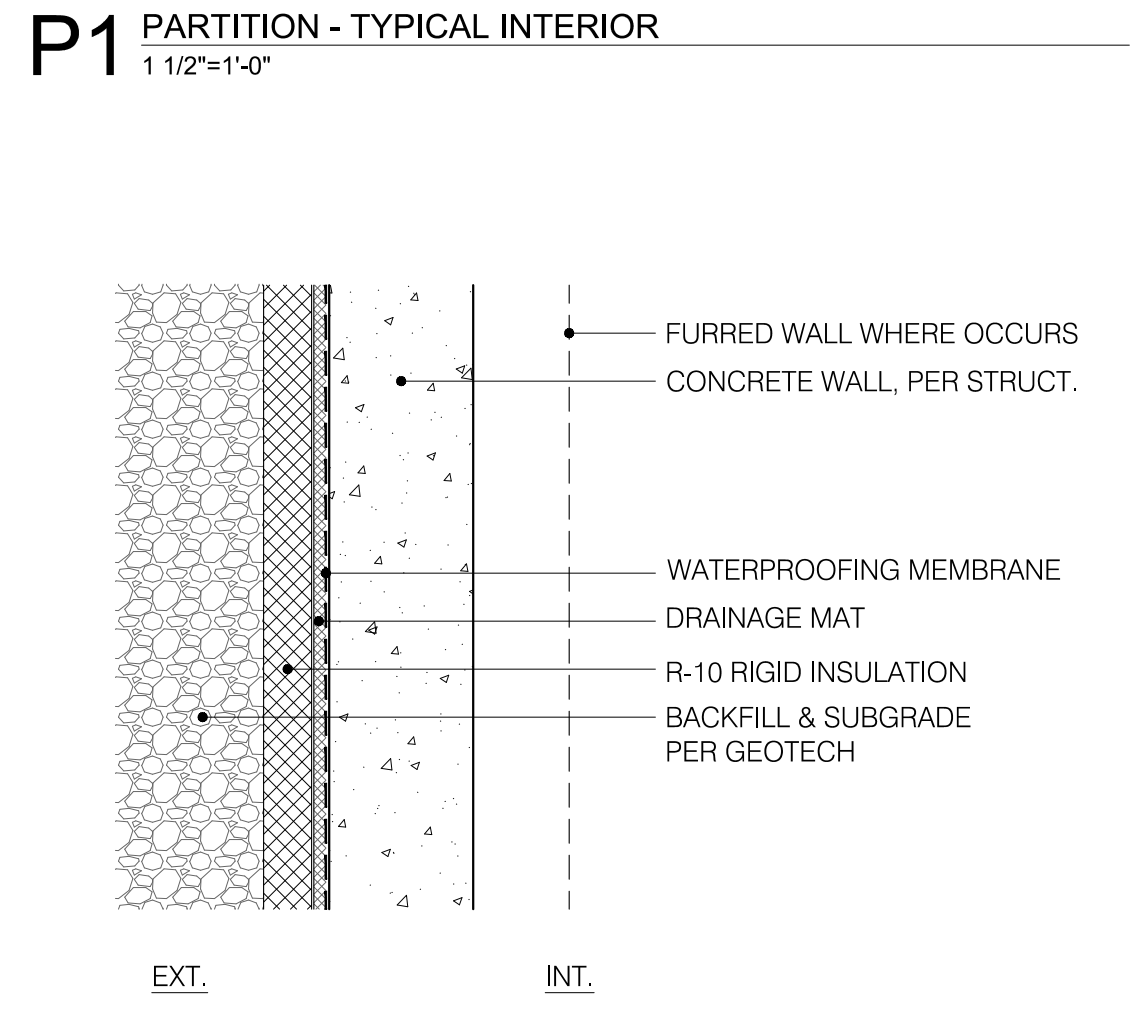

P1 PARTITION - TYPICAL INTERIOR
1 1/2"=1'-0"

TOTAL R-VALUE = R10 MIN. C.I.

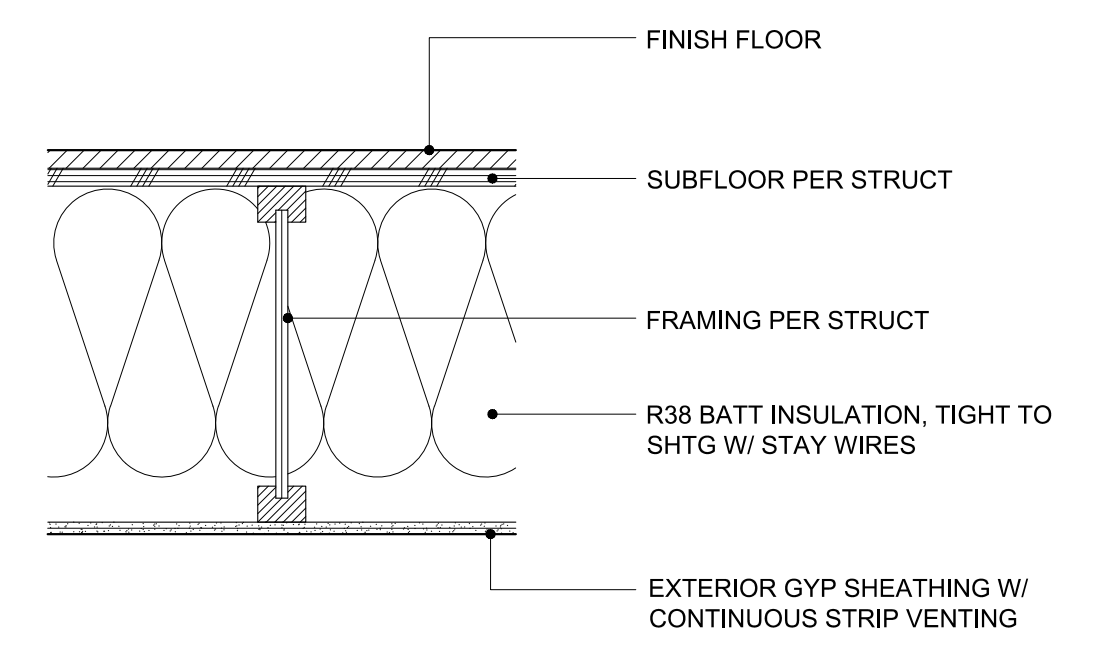

F7 FLOOR - LEVEL 2 OVERHANG
1 1/2"=1'-0"

TOTAL R-VALUE = R-38 MIN.

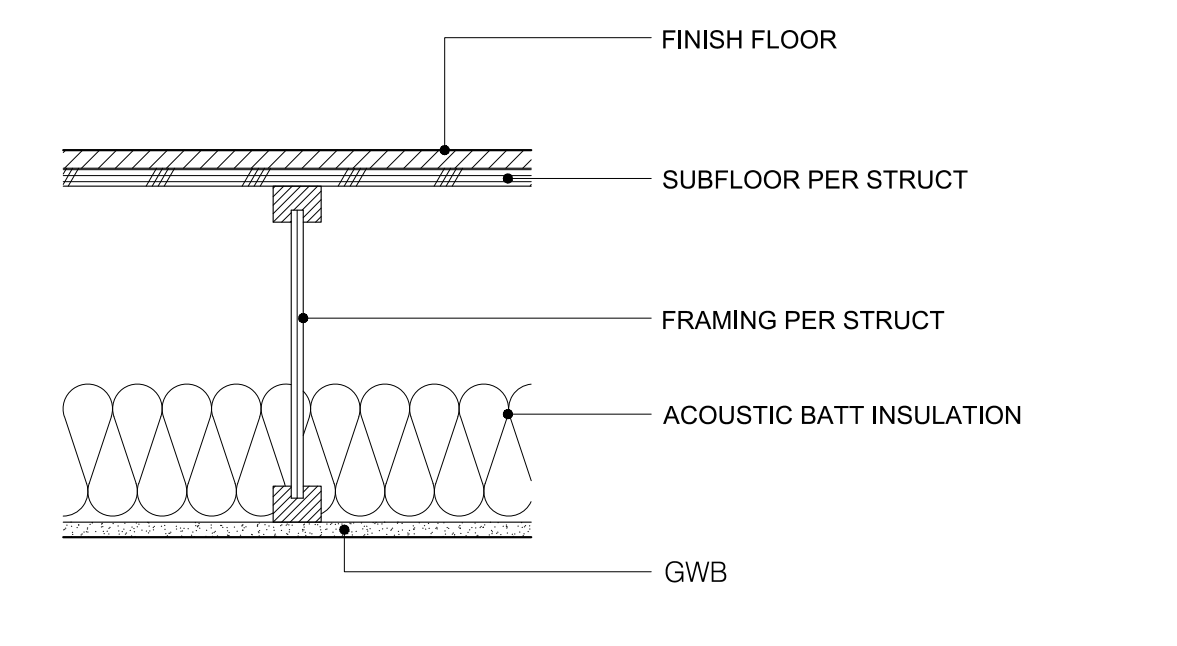

W1 WALL - TYPICAL EXTERIOR
1 1/2"=1'-0"

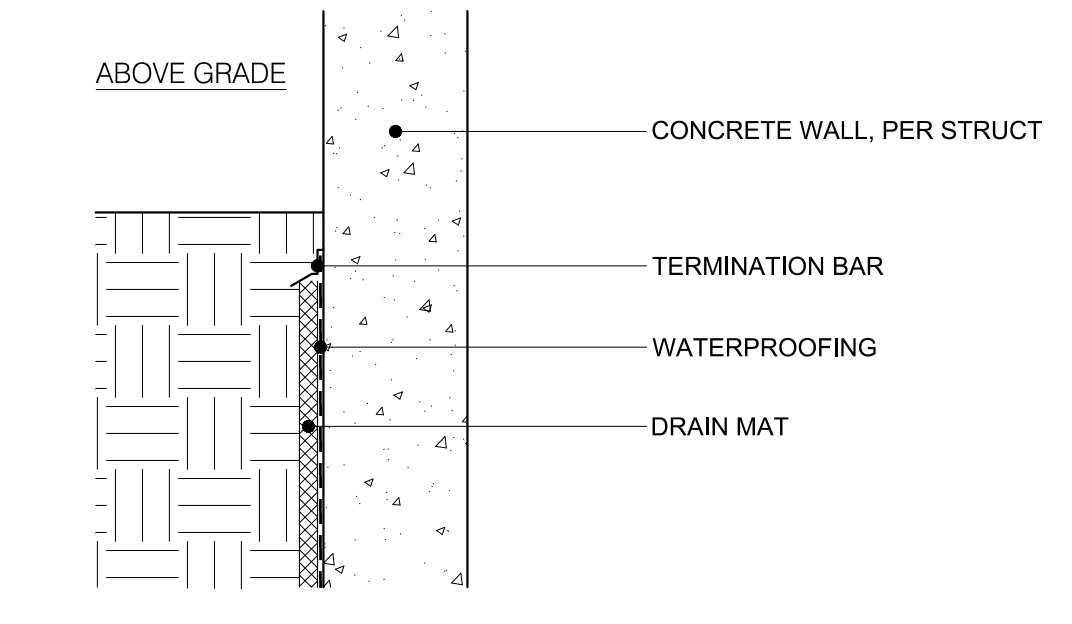

C3 WALL - CRAWL SPACE
1 1/2"=1'-0"

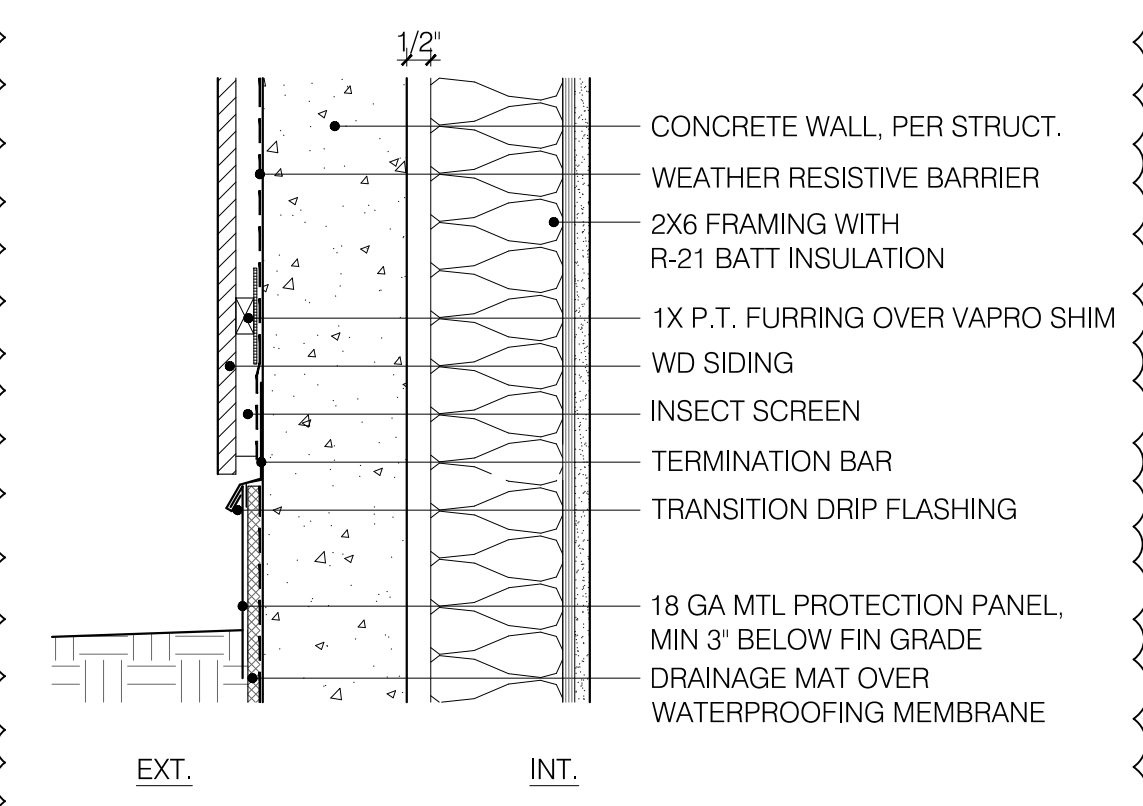

C2 WALL - CONCRETE ABOVE GRADE AT HEATED SPACE
1 1/2"=1'-0"

TOTAL R-VALUE = R10 MIN. C.I.

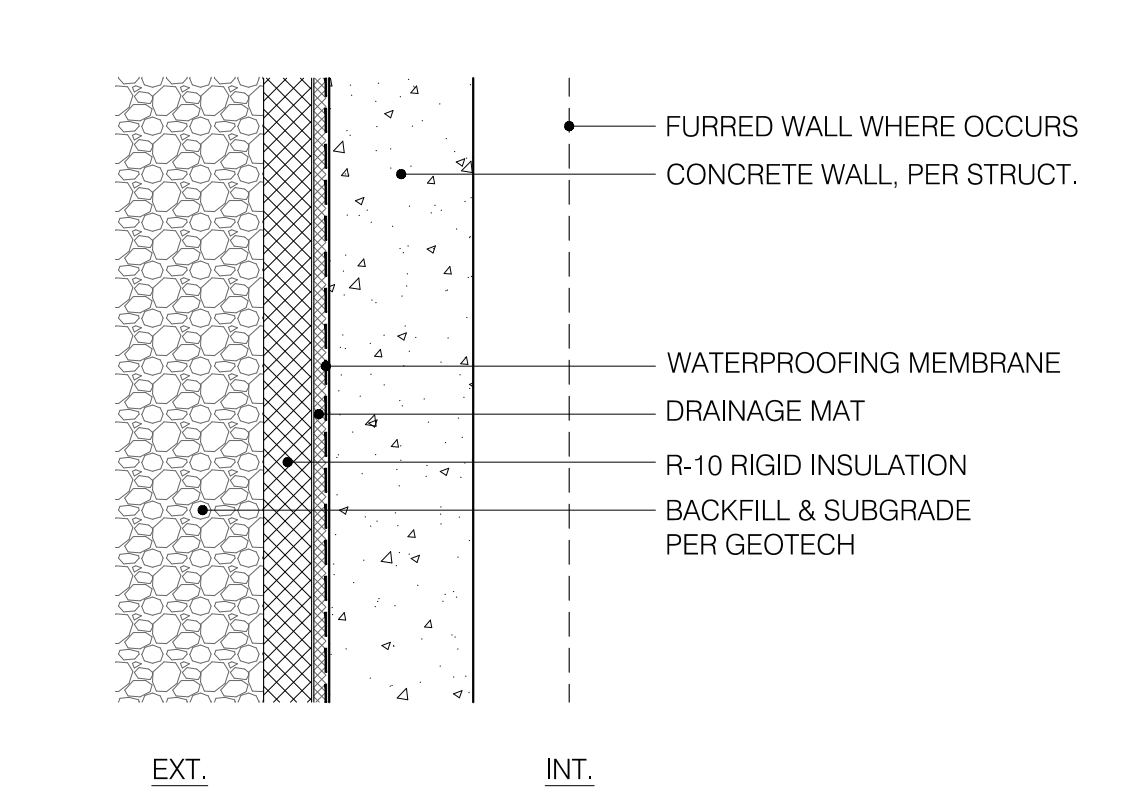

C1 WALL - CONCRETE BELOW GRADE AT HEATED SPACE
1 1/2"=1'-0"

TOTAL R-VALUE = R10 MIN. C.I.

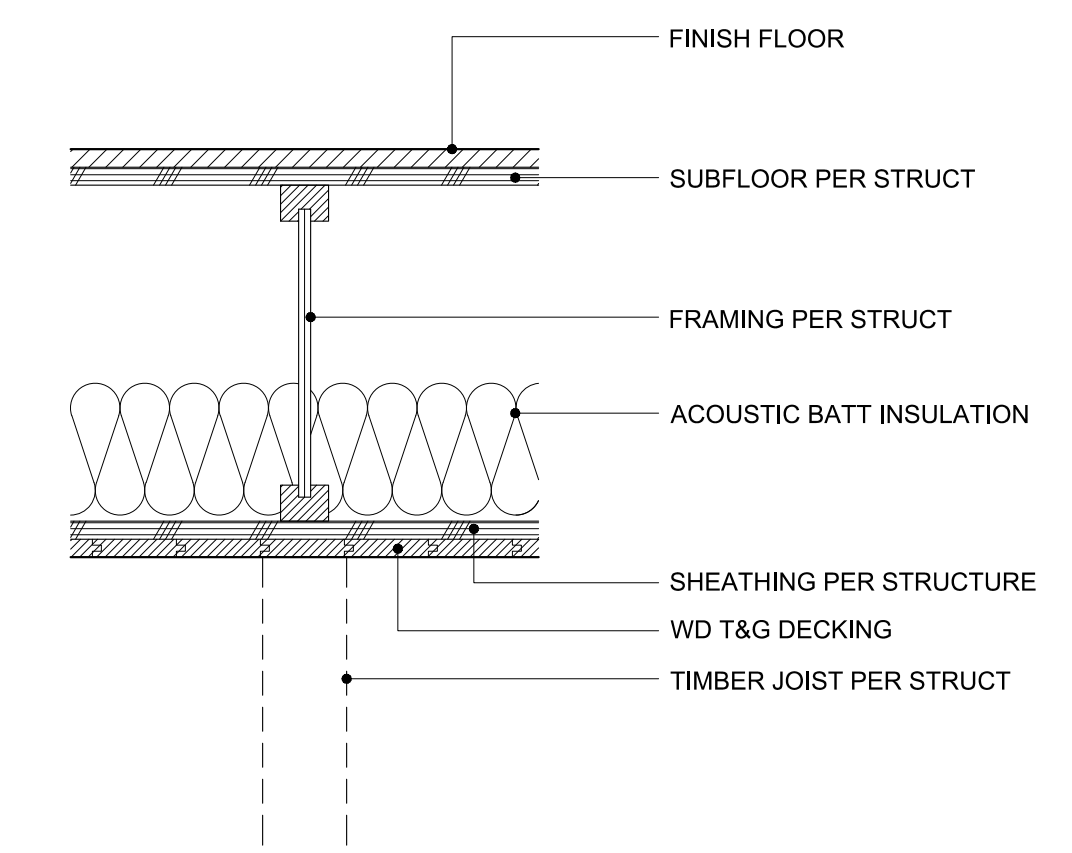

F5 FLOOR - TYPICAL LEVEL 2
1 1/2"=1'-0"

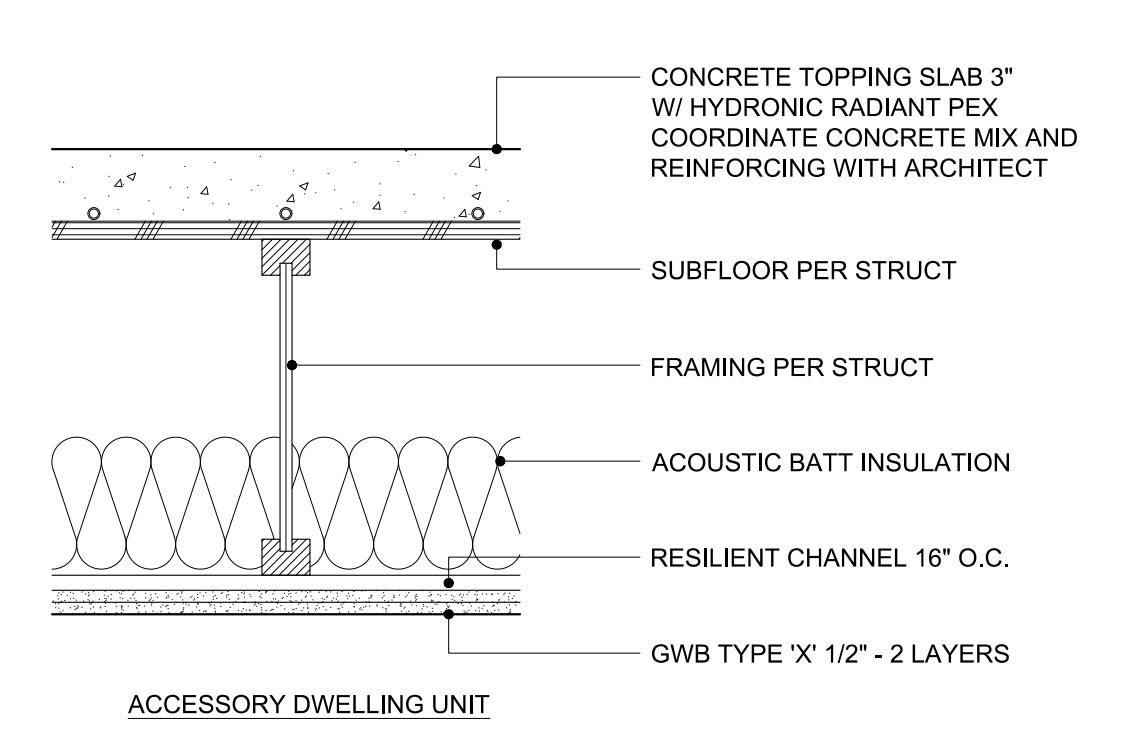

F4 FLOOR - LEVEL 1 OVER ADU
1 1/2"=1'-0"

STC | IIC = 50 MIN

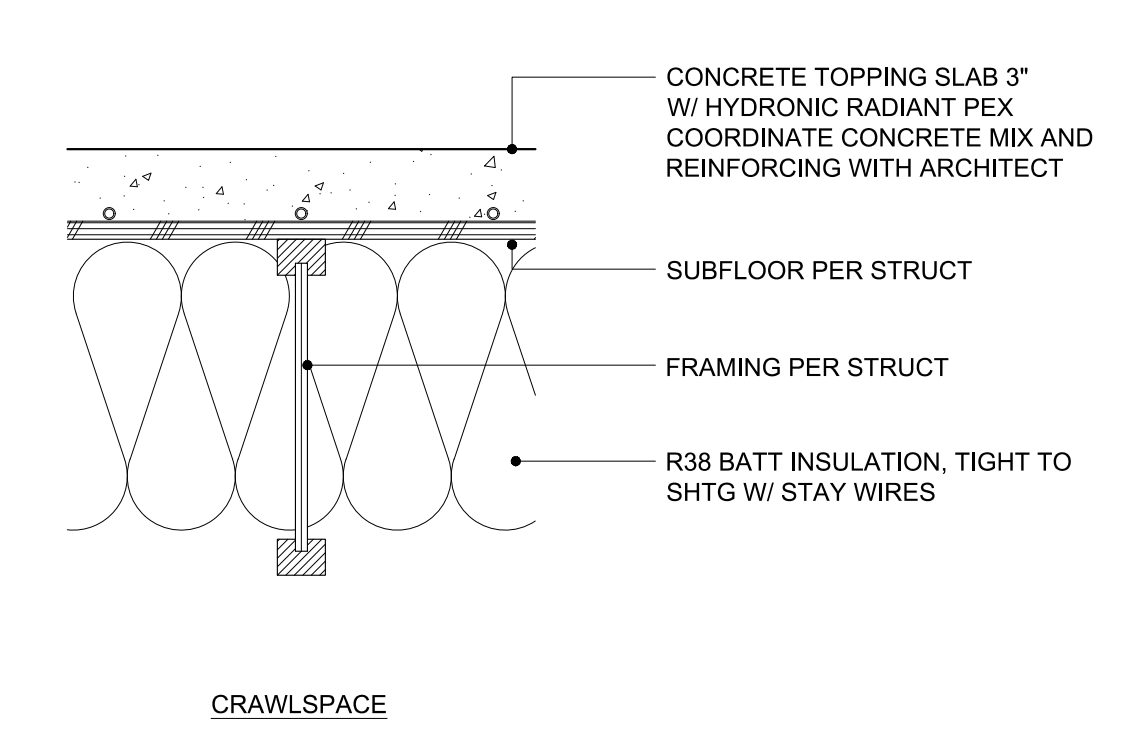

F3 FLOOR - TYPICAL OVER CRAWL SPACE
1 1/2"=1'-0"

TOTAL R-VALUE = R-38 MIN.

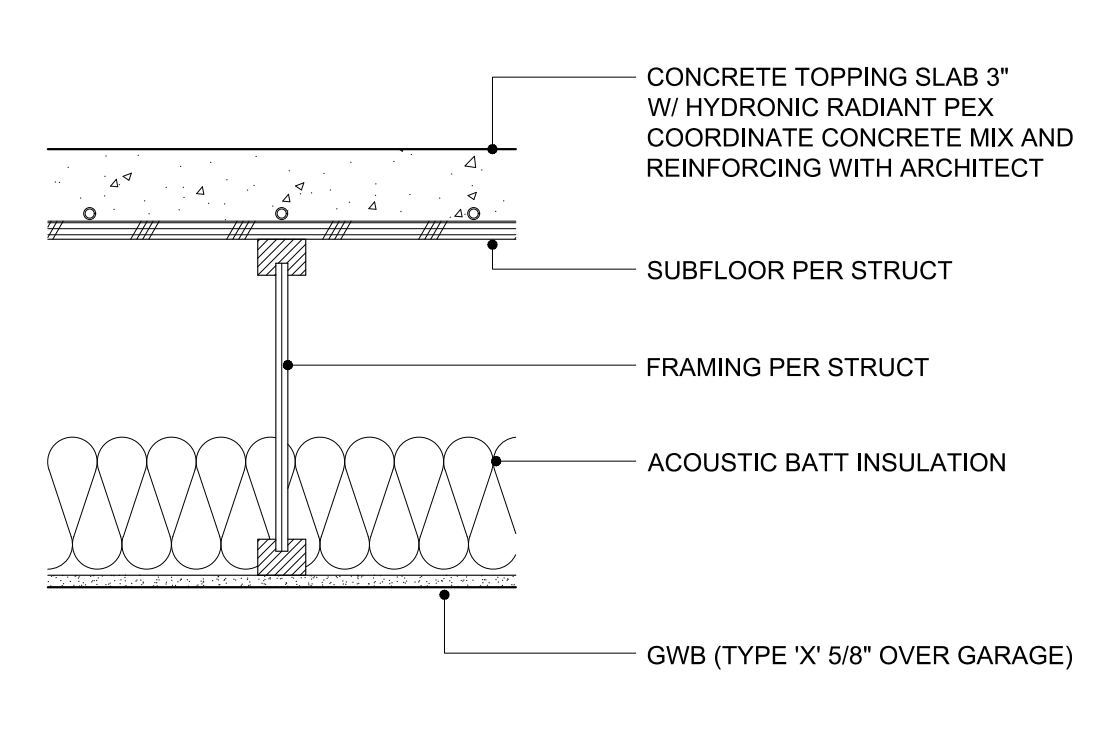

F2 FLOOR - TYPICAL LEVEL 1
1 1/2"=1'-0"

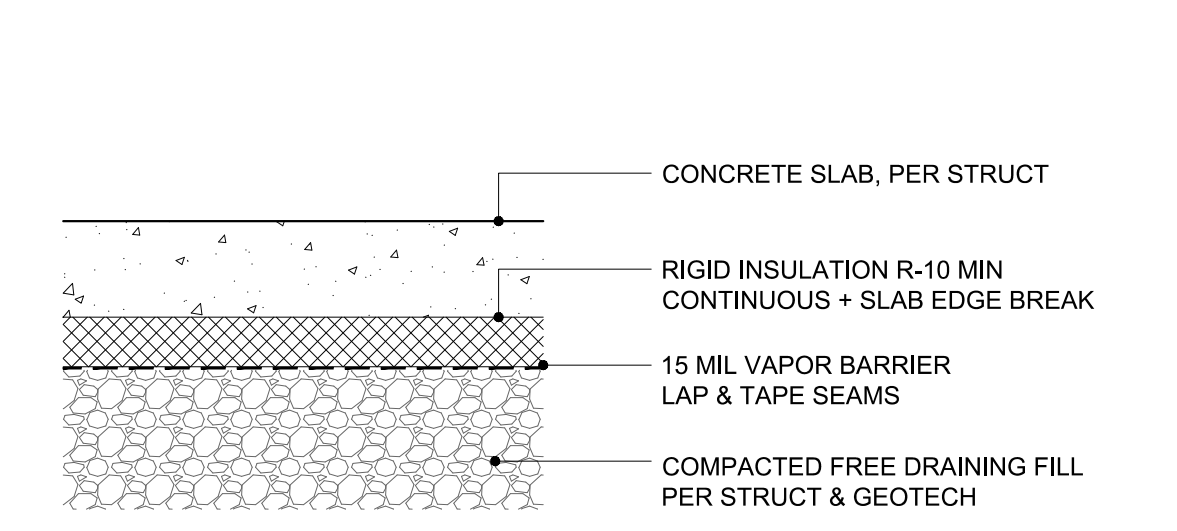

F6 FLOOR - TYPICAL LEVEL 2
1 1/2"=1'-0"

BUILDING PERMIT SUBMITTAL
JAN.18, 2023
BUILDING PERMIT CORRECTION 1
JULY 7, 2023

Jurisdiction Review

Owner Name
SAM FRANKLIN + JUNE CADENHEAD
Project Address
3064 68TH AVE SE
MERCER ISLAND, WA 98040

Sheet Information
Job Number 2209
Drawn DR / TL
Checked SB
Title ASSEMBLIES

Sheet

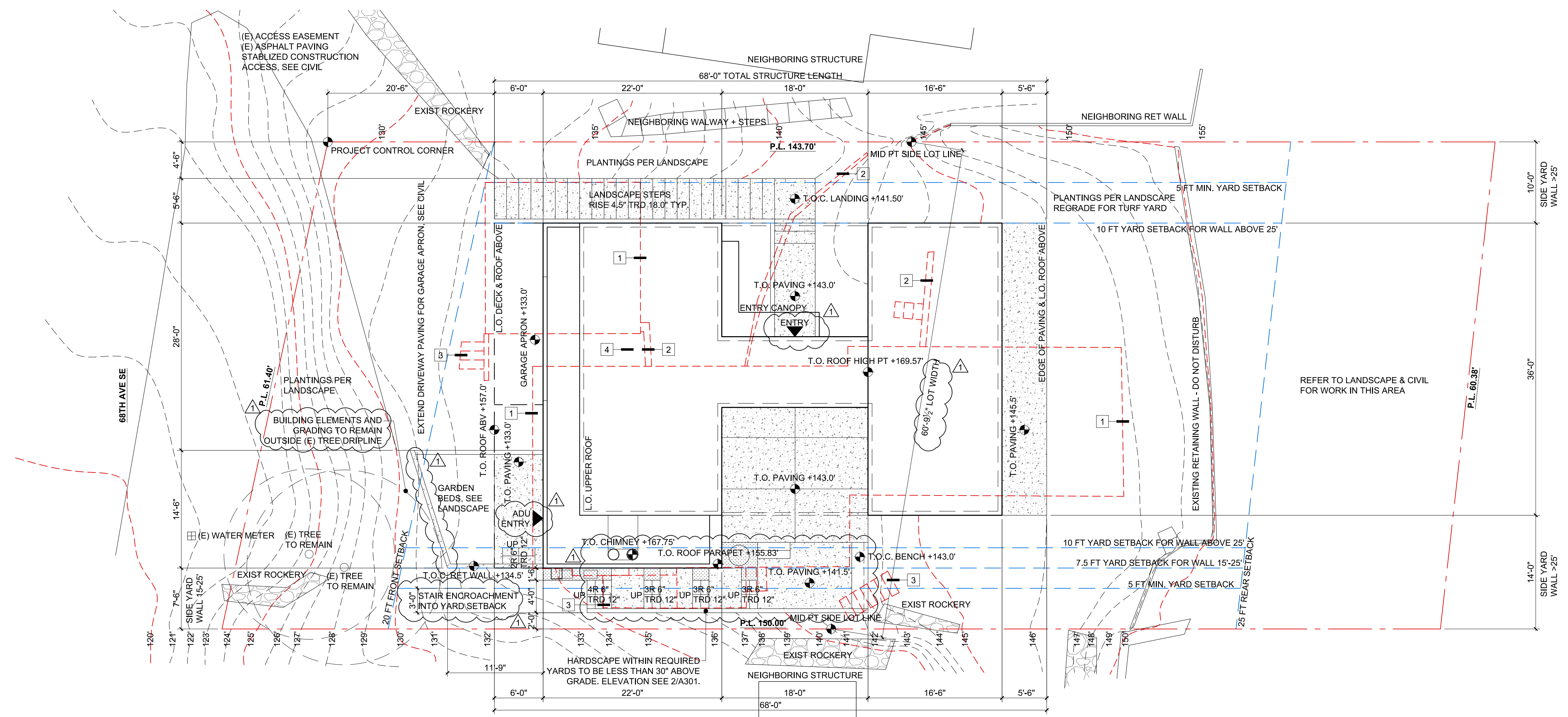

1 SITE PLAN
1/8" = 1'-0"



- SITE DEMO KEY NOTES:**
1. REMOVE STRUCTURE INCLUDING ALL FOUNDATIONS & SLABS
 2. REMOVE RETAINING WALL
 3. REMOVE STEPS & WALKWAYS
 4. DECOMMISSION AND REMOVE ABOVE GROUND OIL TANK

workshop AD

310 South Washington Street
Seattle, WA 98104
206.903.5414 T
206.682.0317 F
www.workshopad.com

3064 68TH AVE SE
BUILDING PERMIT SUBMITTAL

BUILDING PERMIT SUBMITTAL
JAN. 18, 2023
BUILDING PERMIT CORRECTION 1
JULY 7, 2023

Jurisdiction Review

Owner Name
SAM FRANKLIN + JUNE CADENHEAD
Project Address
3064 68TH AVE SE
MERCER ISLAND, WA 98040

Sheet Information
Job Number 2209
Drawn DR / TL
Checked SB
Title
SITE PLAN

Sheet

A100

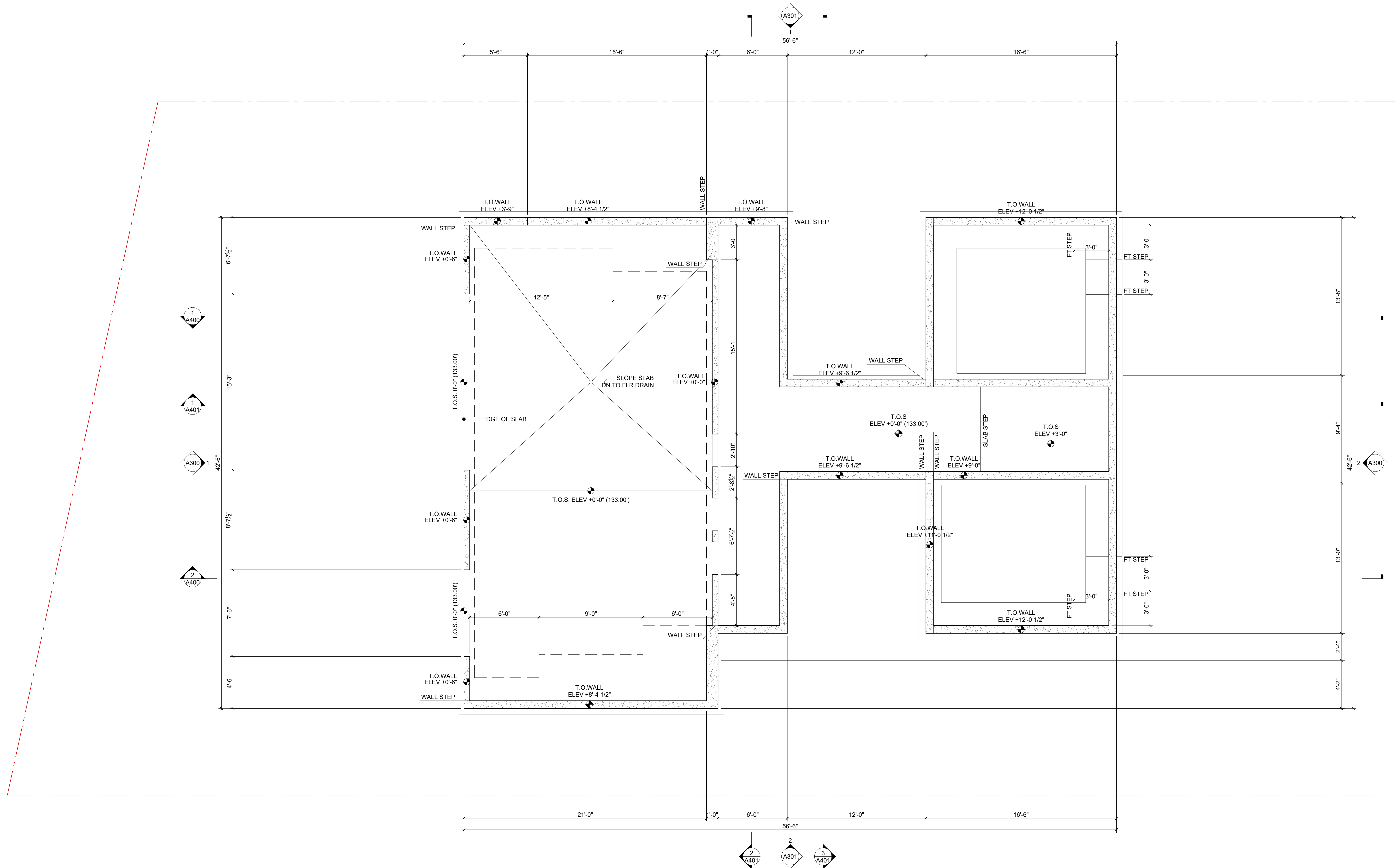

1 FOUNDATION PLAN
1/4" = 1'-0"

GENERAL FOUNDATION NOTES

1. DIMENSIONS TO F.O. CONCRETE. F.O. WALL SHEATHING ALIGNS WITH F.O. CONCRETE.
2. SEE SHEET A000 FOR TYPICAL PARTITION ASSEMBLIES.
3. ALL WOOD FRAMING IN CONTACT WITH CONCRETE TO BE TREATED.
4. FOUNDATION DRAINAGE TO BE PROVIDED PER R405.1.
5. FOUNDATION TO BE DAMP-PROOFED FROM TOP OF FOOTING TO FINISHED GRADE PER R406.1.
6. PROVIDE CLASS I VAPOR RETARDER, LAPPED & SEALED JOINTS, EXTEND MIN 6" UP AND SEAL TO STEM WALL PROVIDE 5 CFM MIN CONTINUOUSLY OPERATING EX-HAUST FAN WITH DISCHARGE TO EXTERIOR PER R408.3

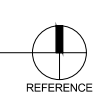

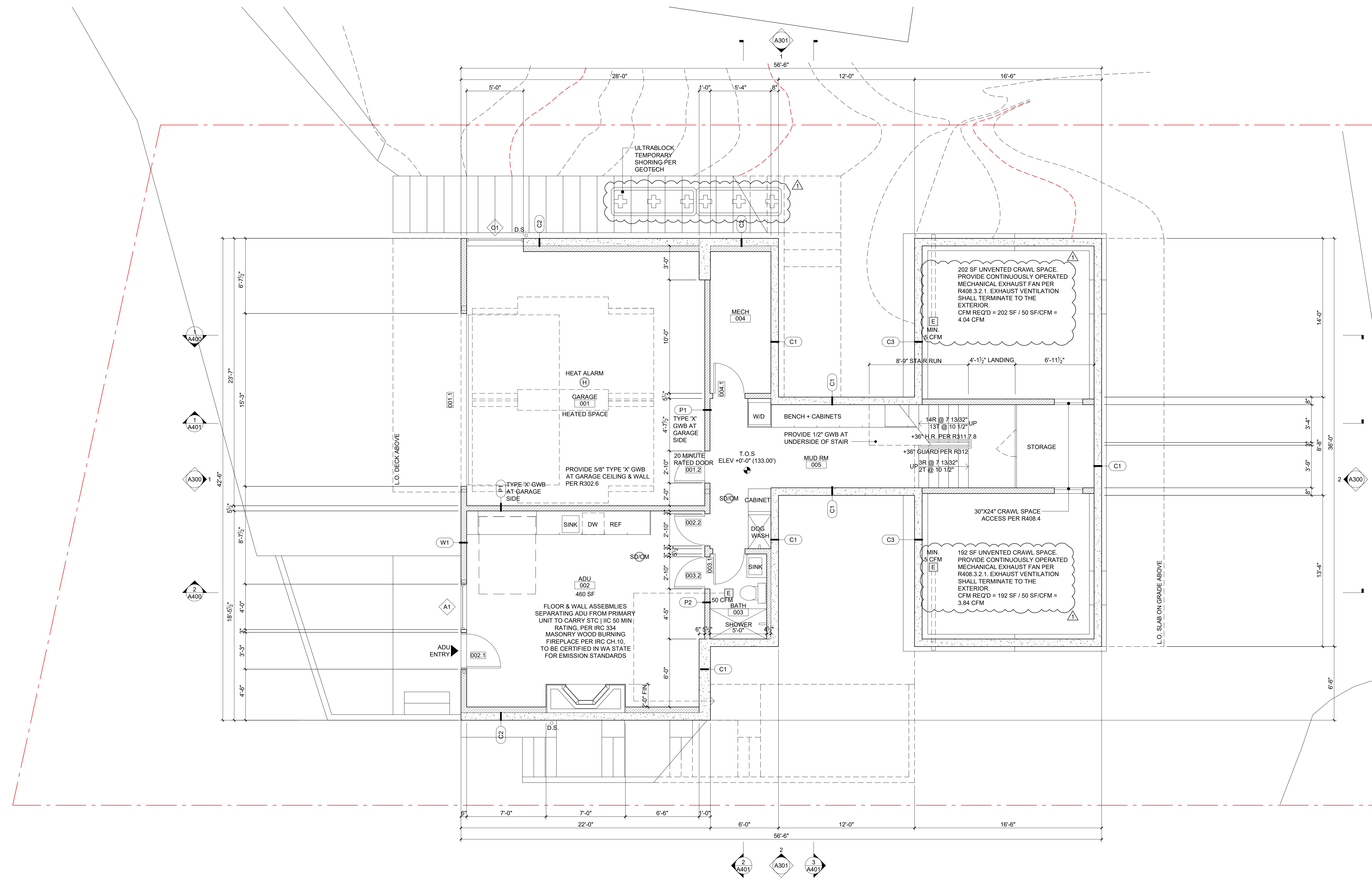

1 BASEMENT PLAN
1/4" = 1'-0"

GENERAL PLAN NOTES

1. SEE SHEET A000 FOR TYPICAL PARTITION ASSEMBLIES
2. ALL WOOD FRAMING IN CONTACT WITH CONCRETE TO BE TREATED
3. DIMENSIONS TO F.O. CONCRETE. F.O. WALL SHEATHING ALIGNS WITH F.O. CONCRETE.
4. PROVIDE GFI OUTLETS AT ALL WET AREAS

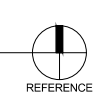

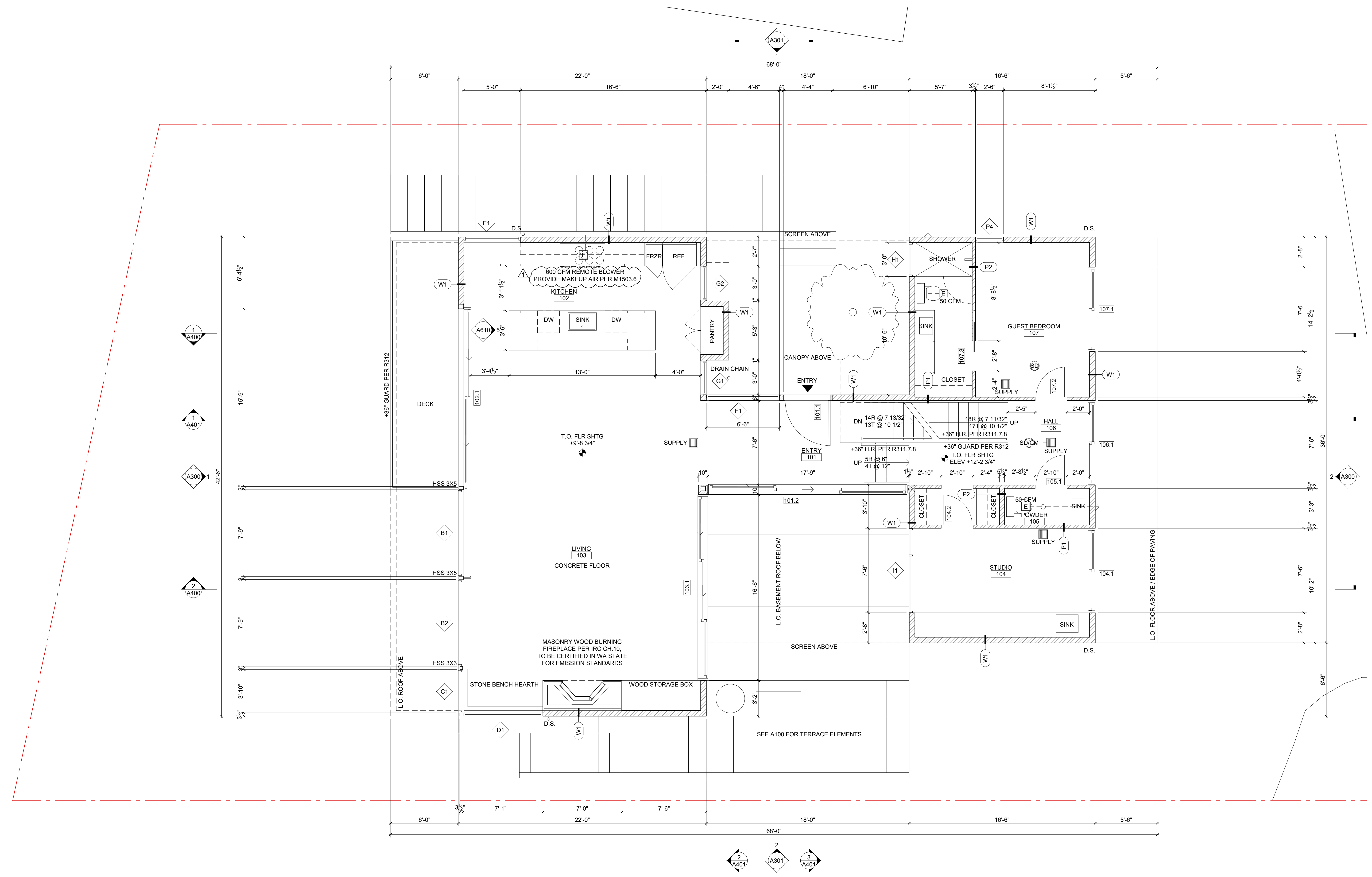

1 LEVEL 1 PLAN
1/4" = 1'-0"

GENERAL PLAN NOTES

- SEE SHEET A000 FOR TYPICAL PARTITION ASSEMBLIES
- ALL WOOD FRAMING IN CONTACT WITH CONCRETE TO BE TREATED
- DIMENSIONS TO F.O. CONCRETE, F.O. WALL SHEATHING ALIGNS WITH F.O. CONCRETE.
- PROVIDE GFI OUTLETS AT ALL WET AREAS

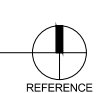

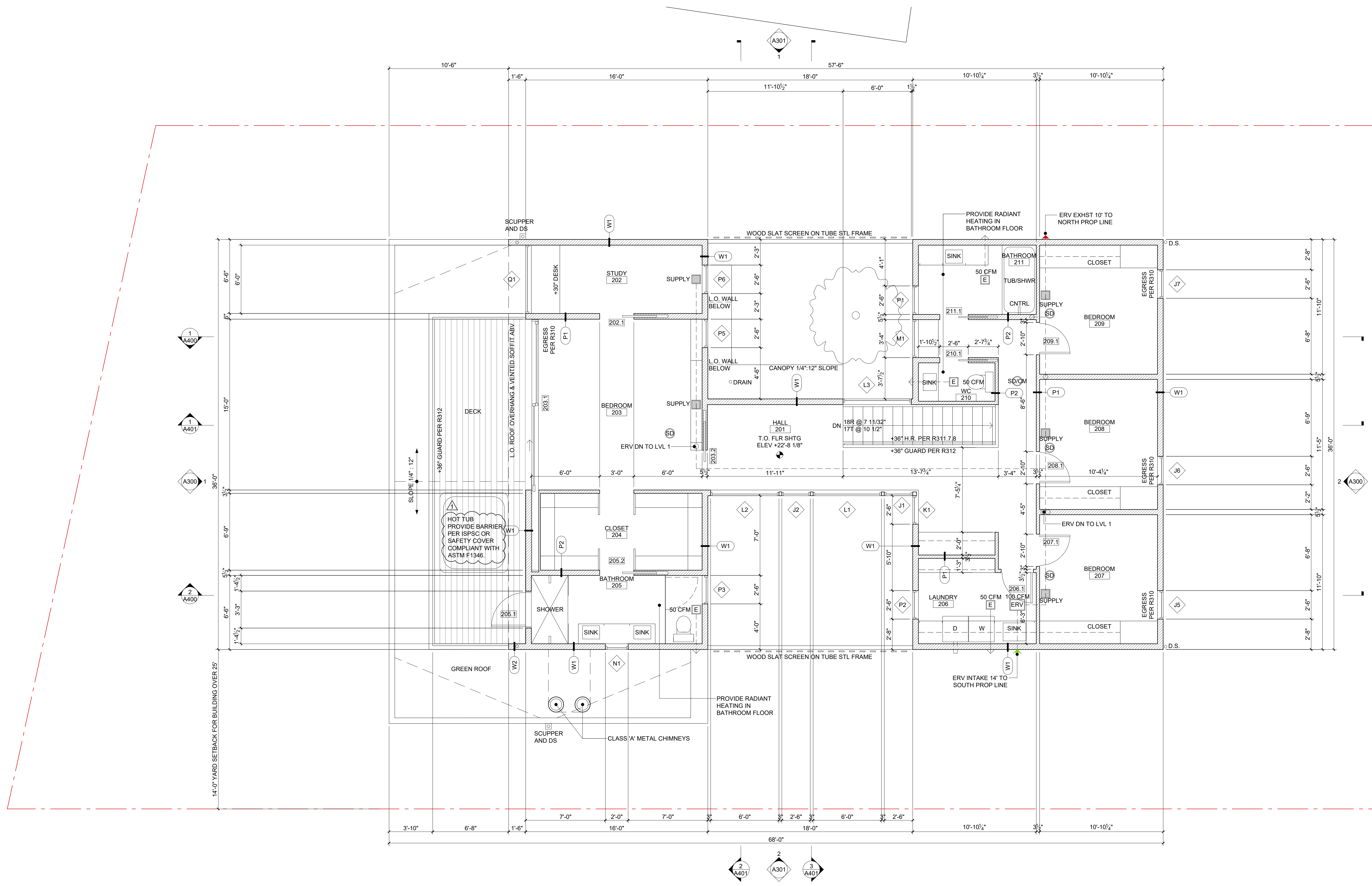

1 LEVEL 2 PLAN
1/4" = 1'-0"

- GENERAL PLAN NOTES
- SEE SHEET A000 FOR TYPICAL PARTITION ASSEMBLIES
 - ALL WOOD FRAMING IN CONTACT WITH CONCRETE TO BE TREATED
 - DIMENSIONS TO F.O. CONCRETE. F.O. WALL SHEATHING ALIGNS WITH F.O. CONCRETE.
 - PROVIDE GFI OUTLETS AT ALL WET AREAS

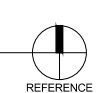

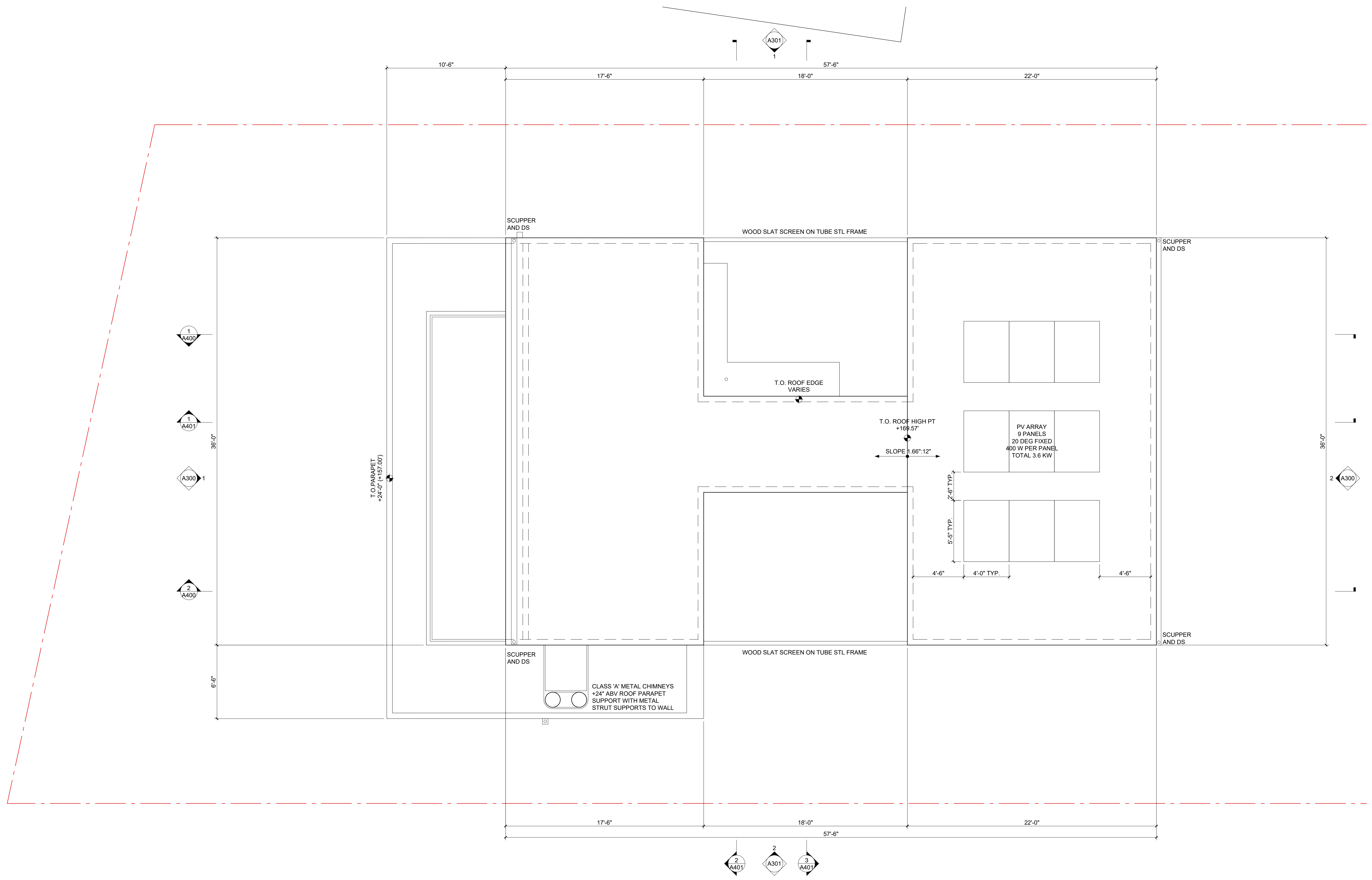

1 ROOF PLAN
1/4" = 1'-0"

Month	Solar Radiation (kWh/m ² /day)	AC Energy (kWh)
January	1.05	104
February	2.01	202
March	3.07	304
April	4.08	410
May	5.11	511
June	6.08	608
July	6.94	694
August	5.88	582
September	4.03	393
October	2.07	204
November	1.07	105
December	1.01	101
Annual	3.82	3,788

Month	Jan	Feb	Mar	Apr	May	Jun	Jul	Aug	Sep	Oct	Nov	Dec
Monthly Production (kWh)	104	202	304	410	511	608	694	582	393	204	105	101

Parameter	Value
Location	3064 68th Ave SE
Latitude	47.37 N
Longitude	122.20 W
PV System Specifications	
DC System Size	4.5 kW
Module Type	Monocrystalline
Array Type	Fixed (roof mount)
System Losses	14.0%
Array Tilt	20°
Array Azimuth	180°
DC to AC Conversion	1.1
Inverter Efficiency	96%
Ground Coverage Ratio	0.4%
Albedo	0.2 (from weather file)
Shading	No Shading
Monthly Production Loss	Jan: 7%, Feb: 10%, Mar: 12%, Apr: 14%, May: 15%, Jun: 16%, Jul: 15%, Aug: 12%, Sep: 10%, Oct: 7%, Nov: 5%, Dec: 4%
Performance Ratio	76.0%
DC Capacity Factor	10.0%

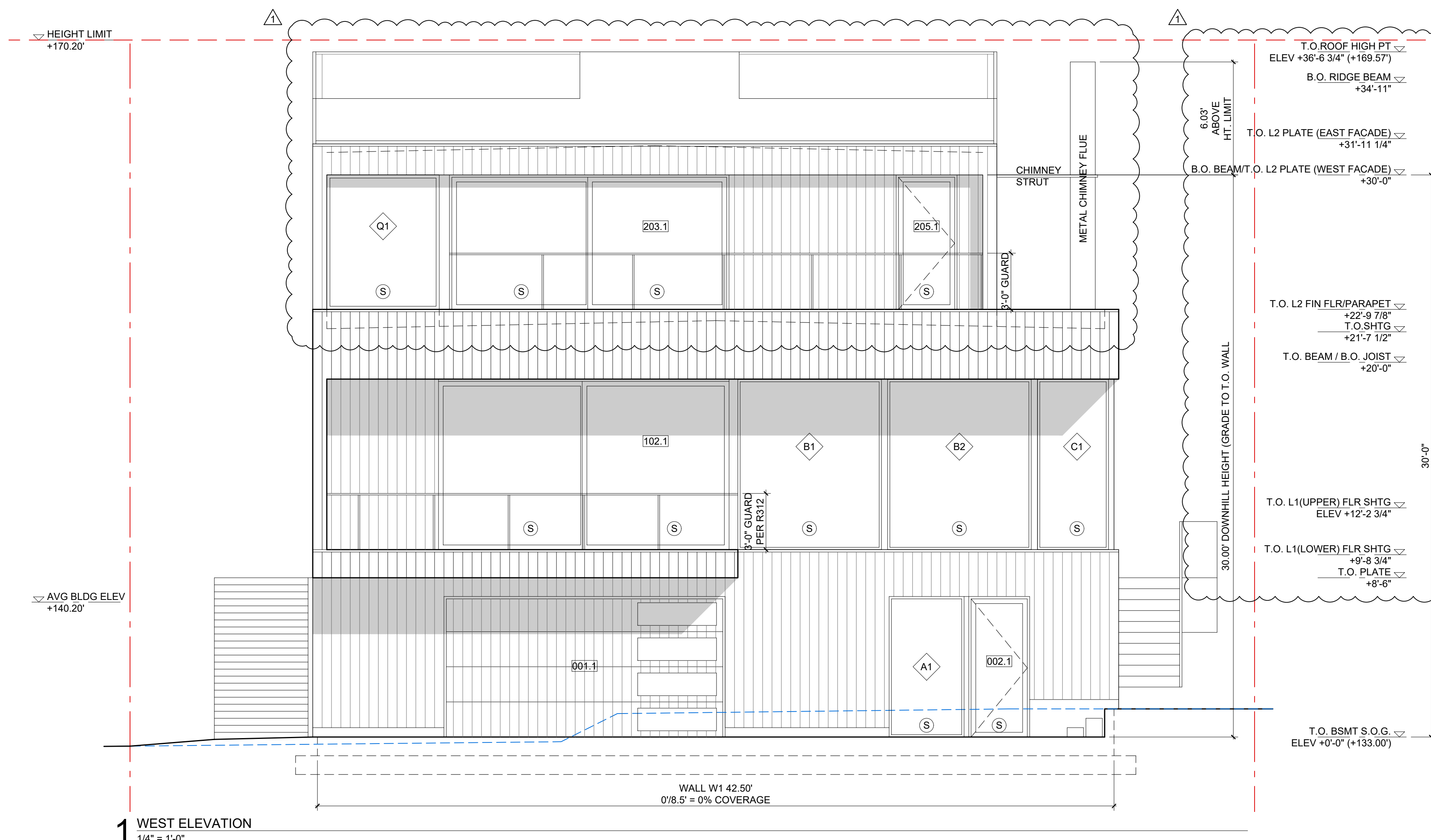

1 WEST ELEVATION
1/4" = 1'-0"

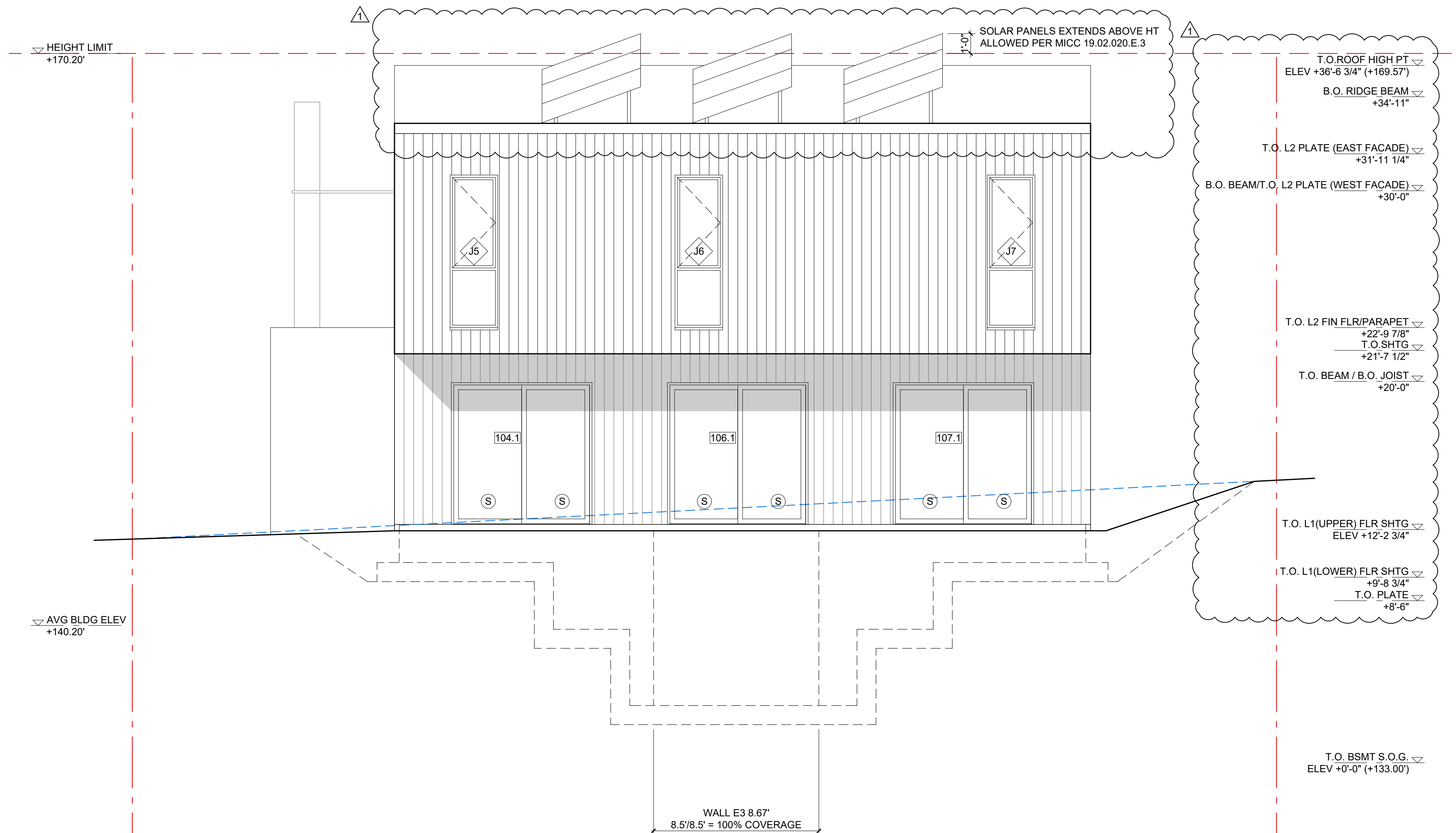

2 EAST ELEVATION
1/4" = 1'-0"

- GENERAL ELEVATION & SECTION NOTES:**
1. SAFETY GLAZING (S) REQUIRED PER R308.
 2. VERTICAL GLAZING TO HAVE A MAX. U-VALUE OF 0.28 PER PRESCRIPTIVE REQUIREMENTS - SEE G000.
 3. SEE A800 FOR DOOR & WINDOW SCHEDULES.
 4. EGRESS PER R310 & R311.
 5. EXHAUST OUTLETS TO BE A MINIMUM OF (3) THREE FEET FROM ANY OPENING.
 6. SEE A000 FOR FLOOR, WALL, AND ROOF ASSEMBLIES.
 7. HANDRAIL REQUIREMENTS PER R311.7.8
 8. GUARDS PER R312.1.3. MAX 4-INCH SPHERE PASS THROUGH.
 9. PER R301.5 GUARD INFILL COMPONENTS DESIGNED TO WITHSTAND A HORIZONTALLY NORMAL APPLIED LOAD OF 50 PSF ON AN AREA EQUAL TO ONE SQFT. ALL TOP RAILS TO RESIST A 200 LB CONCENTRATED LOAD.
 10. PROVIDE STRIP VENTILATION AT EAVES PER R806.

workshop AD

310 South Washington Street
Seattle, WA 98104
206.903.5414 T
206.682.0317 F
www.workshopad.com

3064 68TH AVE SE
BUILDING PERMIT SUBMITTAL

BUILDING PERMIT SUBMITTAL
JAN 18, 2023
BUILDING PERMIT CORRECTION 1
JULY 7, 2023

Jurisdiction Review

Owner Name
SAM FRANKLIN + JUNE CADENHEAD
Project Address
3064 68TH AVE SE
MERCER ISLAND, WA 98040

Sheet Information
Job Number 2209
Drawn DR / TL
Checked SB
Title
ELEVATIONS

Sheet

A300

GENERAL ELEVATION & SECTION NOTES:

1. SAFETY GLAZING (S) REQUIRED PER R308.
2. VERTICAL GLAZING TO HAVE A MAX. U-VALUE OF 0.28 PER PRESCRIPTIVE REQUIREMENTS - SEE G000.
3. SEE A800 FOR DOOR & WINDOW SCHEDULES.
4. EGRESS PER R310 & R311.
5. EXHAUST OUTLETS TO BE A MINIMUM OF (3) THREE FEET FROM ANY OPENING.
6. SEE A000 FOR FLOOR, WALL, AND ROOF ASSEMBLIES.
7. HANDRAIL REQUIREMENTS PER R311.7.8
8. GUARDS PER R312.1.3. MAX 4-INCH SPHERE PASS THROUGH.
9. PER R301.5 GUARD INFILL COMPONENTS DESIGNED TO WITHSTAND A HORIZONTALLY NORMAL APPLIED LOAD OF 50 PSF ON AN AREA EQUAL TO ONE SQFT. ALL TOP RAILS TO RESIST A 200 LB CONCENTRATED LOAD.
10. PROVIDE STRIP VENTILATION AT EAVES PER R806.

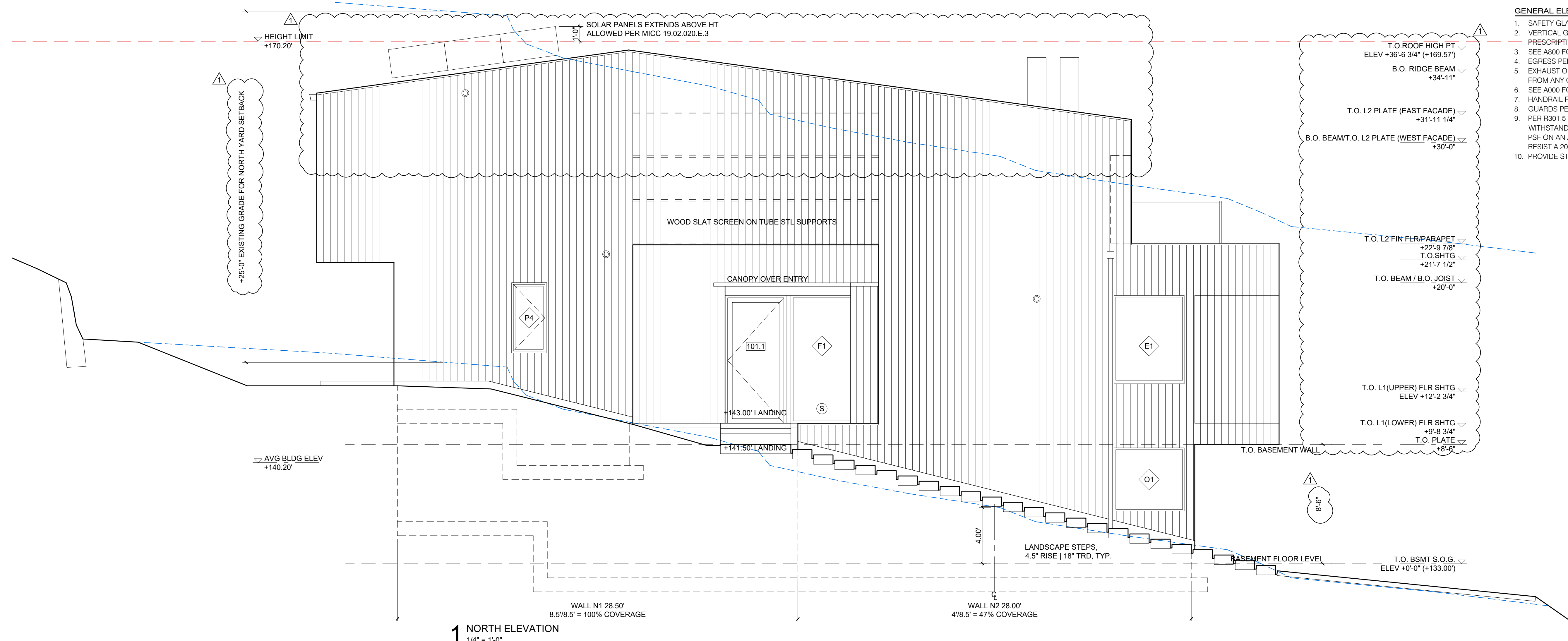

1 NORTH ELEVATION
1/4" = 1'-0"

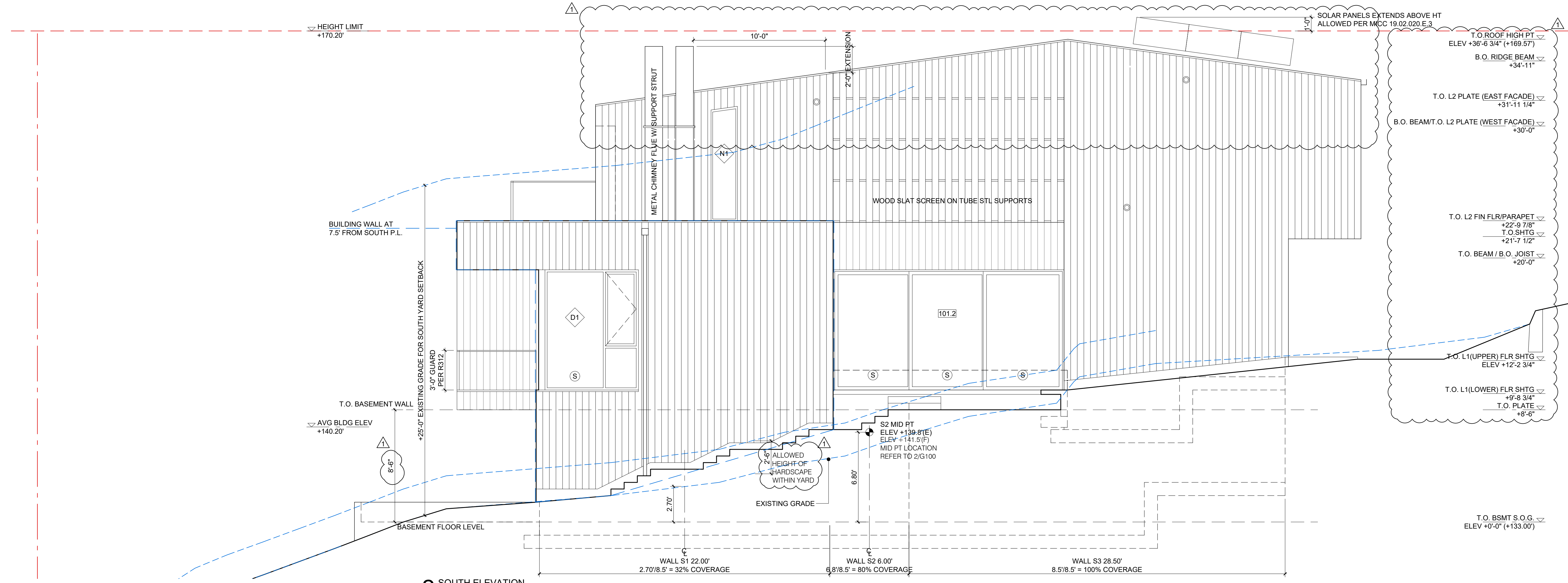

2 SOUTH ELEVATION
1/4" = 1'-0"

BUILDING PERMIT SUBMITTAL	JAN 18, 2023
BUILDING PERMIT CORRECTION 1	JULY 7, 2023

Jurisdiction Review

Owner Name
SAM FRANKLIN + JUNE CADENHEAD
Project Address
3064 68TH AVE SE
MERCER ISLAND, WA 98040

Sheet Information	
Job Number	2209
Drawn	DR / TL
Checked	SB
Title ELEVATIONS	

Sheet

GENERAL ELEVATION & SECTION NOTES:

- SAFETY GLAZING (S) REQUIRED PER R308.
- VERTICAL GLAZING TO HAVE A MAX. U-VALUE OF 0.28 PER PRESCRIPTIVE REQUIREMENTS - SEE G000.
- SEE A800 FOR DOOR & WINDOW SCHEDULES.
- EGRESS PER R310 & R311.
- EXHAUST OUTLETS TO BE A MINIMUM OF (3) THREE FEET FROM ANY OPENING.
- SEE A300 FOR FLOOR, WALL, AND ROOF ASSEMBLIES.
- HANDRAIL REQUIREMENTS PER R311.7.8
- GUARDS PER R312.1.3, MAX 4-INCH SPHERE PASS THROUGH.
- PER R301.5 GUARD INFILL COMPONENTS DESIGNED TO WITHSTAND A HORIZONTALLY NORMAL APPLIED LOAD OF 50 PSF ON AN AREA EQUAL TO ONE SQFT. ALL TOP RAILS TO RESIST A 200 LB CONCENTRATED LOAD.
- PROVIDE STRIP VENTILATION AT EAVES PER R806.

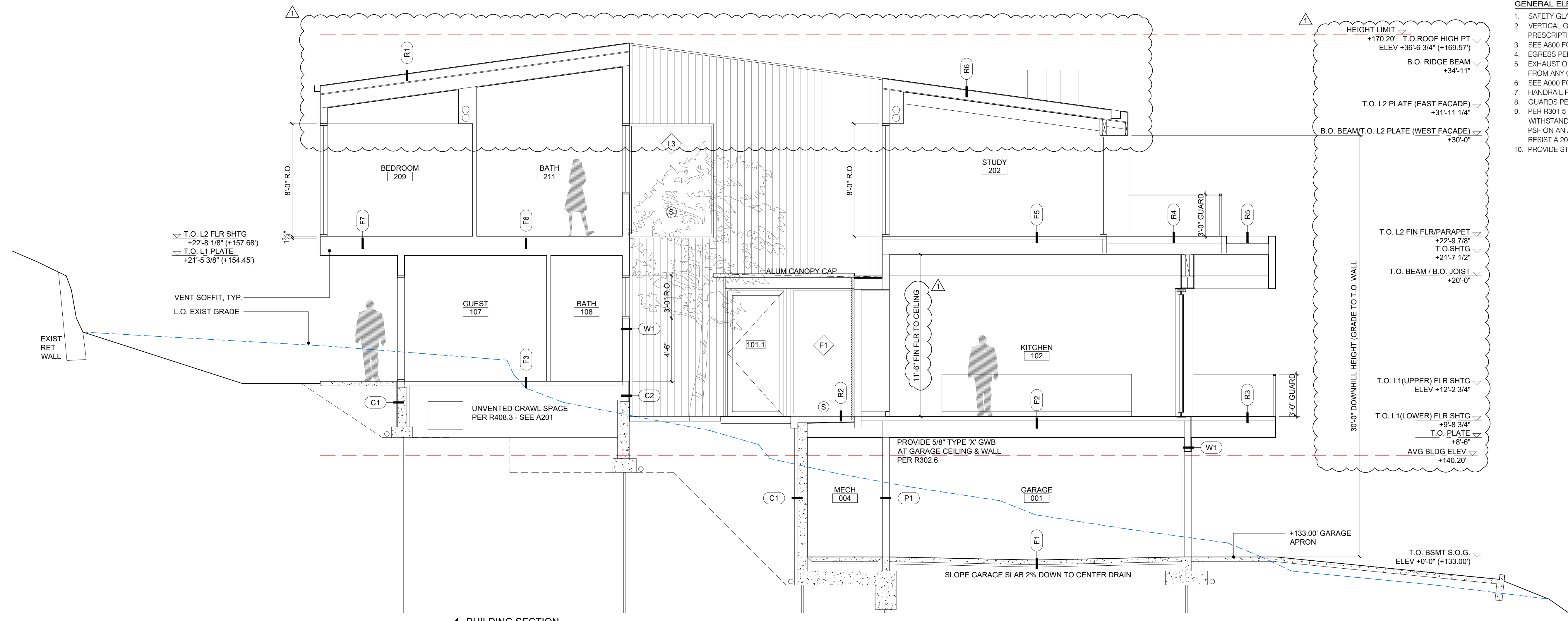

1 BUILDING SECTION
1/4" = 1'-0"

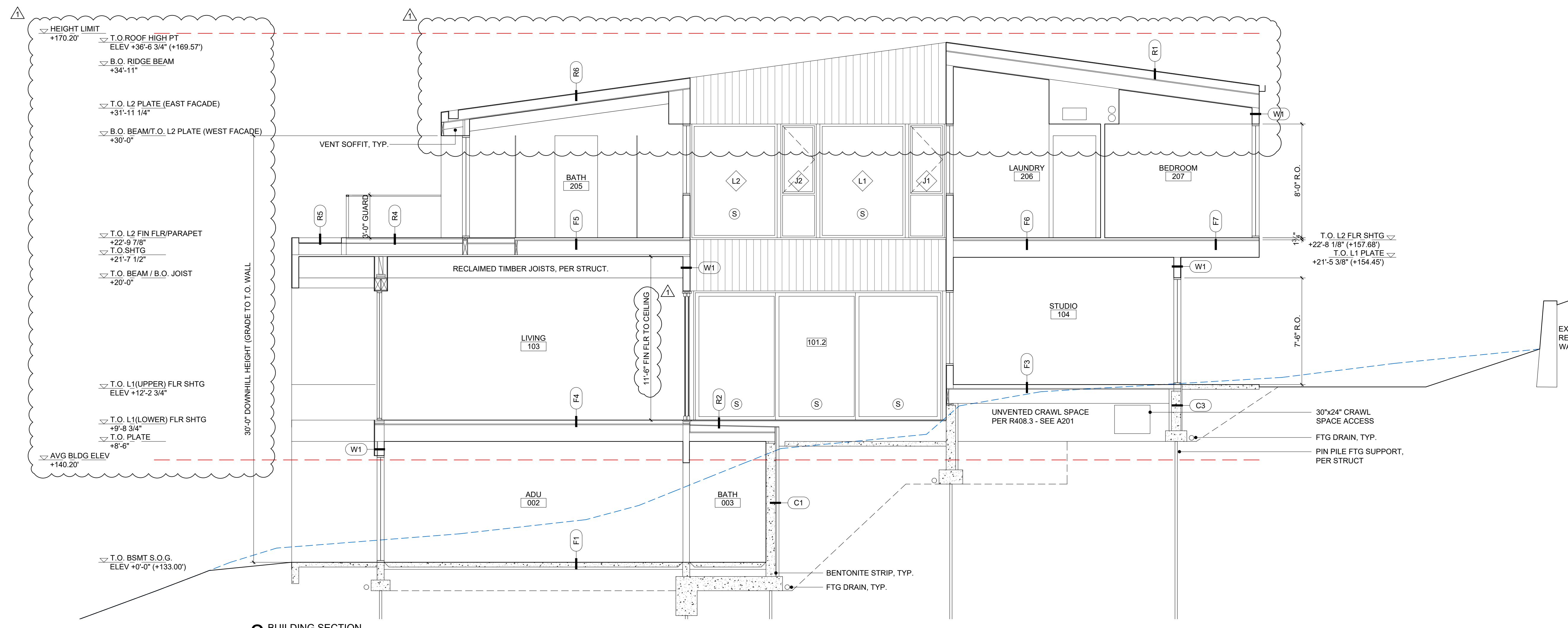

2 BUILDING SECTION
1/4" = 1'-0"

BUILDING PERMIT SUBMITTAL
JAN 18, 2023
BUILDING PERMIT CORRECTION 1
JULY 7, 2023

Jurisdiction Review

Owner Name
SAM FRANKLIN + JUNE CADENHEAD
Project Address
3064 68TH AVE SE
MERCER ISLAND, WA 98040

Sheet Information	
Job Number	2209
Drawn	DR / TL
Checked	SB
Title	BUILDING SECTIONS

Sheet

GENERAL ELEVATION & SECTION NOTES:

- SAFETY GLAZING (S) REQUIRED PER R308.
- VERTICAL GLAZING TO HAVE A MAX. U-VALUE OF 0.28 PER PRESCRIPTIVE REQUIREMENTS - SEE G000.
- SEE A800 FOR DOOR & WINDOW SCHEDULES.
- EGRESS PER R310 & R311.
- EXHAUST OUTLETS TO BE A MINIMUM OF (3) THREE FEET FROM ANY OPENING.
- SEE A000 FOR FLOOR, WALL, AND ROOF ASSEMBLIES.
- HANDRAIL REQUIREMENTS PER R311.7.8
- GUARDS PER R312.1.3. MAX 4-INCH SPHERE PASS THROUGH.
- PER R301.5 GUARD INFILL COMPONENTS DESIGNED TO WITHSTAND A HORIZONTALLY NORMAL APPLIED LOAD OF 50 PSF ON AN AREA EQUAL TO ONE SQFT. ALL TOP RAILS TO RESIST A 200 LB CONCENTRATED LOAD.
- PROVIDE STRIP VENTILATION AT EAVES PER R806.

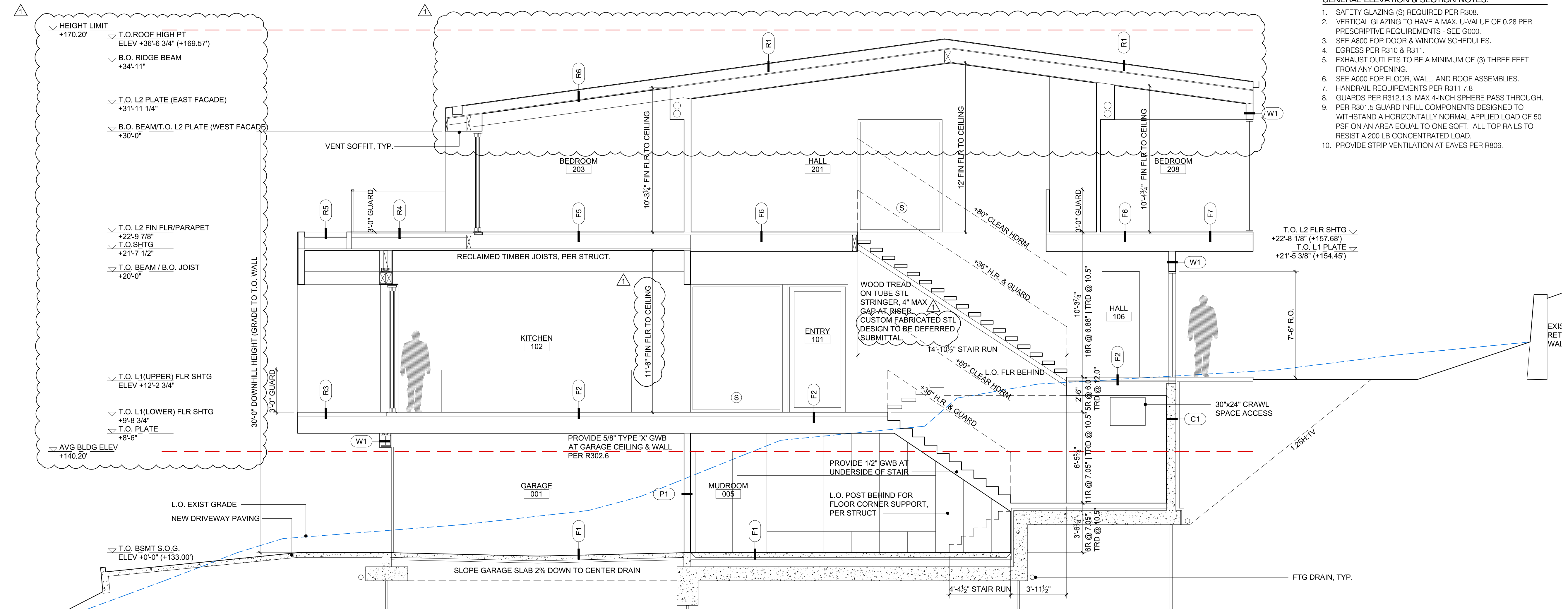

1 BUILDING SECTION
1/4" = 1'-0"

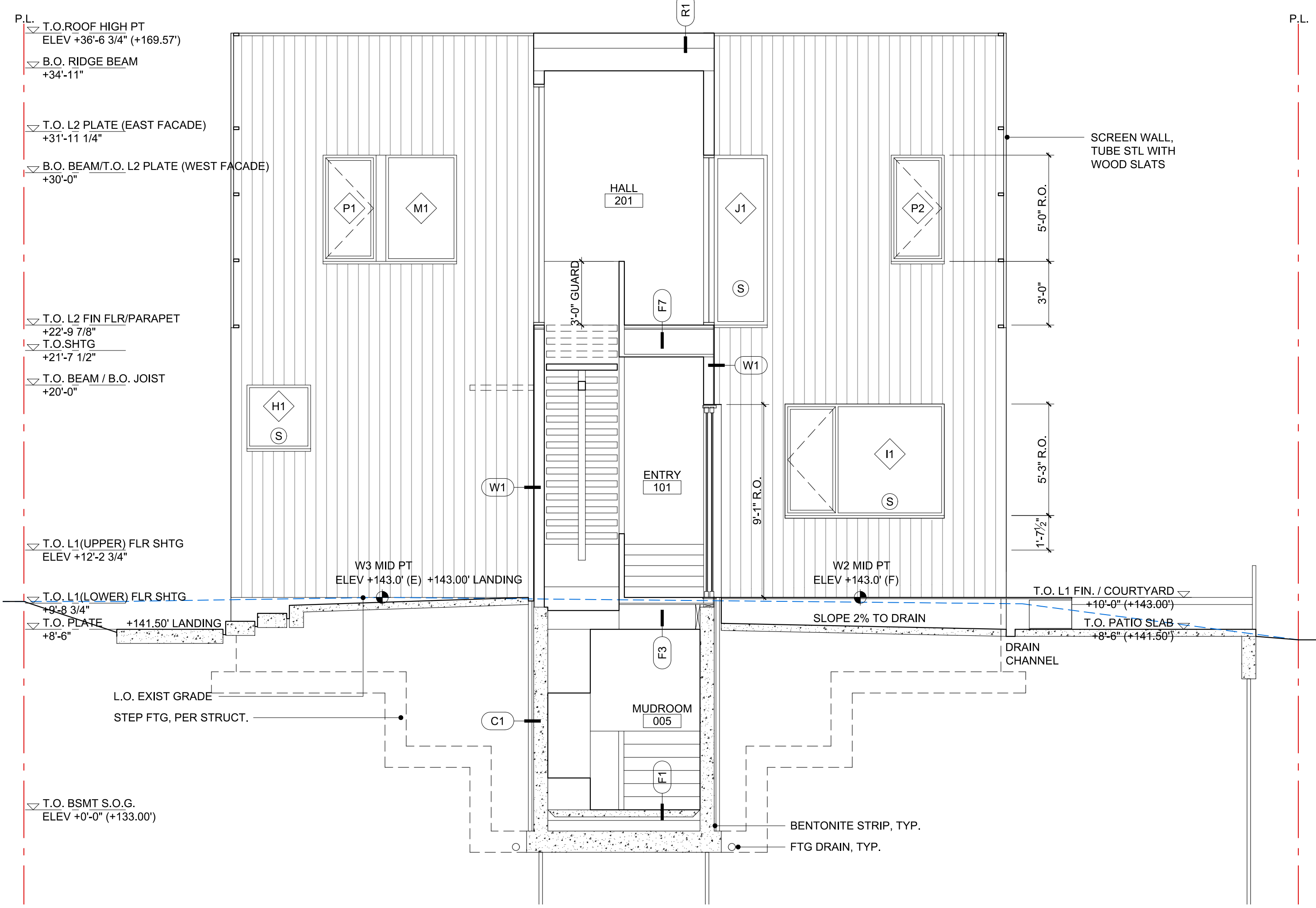

3 BUILDING SECTION | COURTYARD EAST ELEVATION
1/4" = 1'-0"

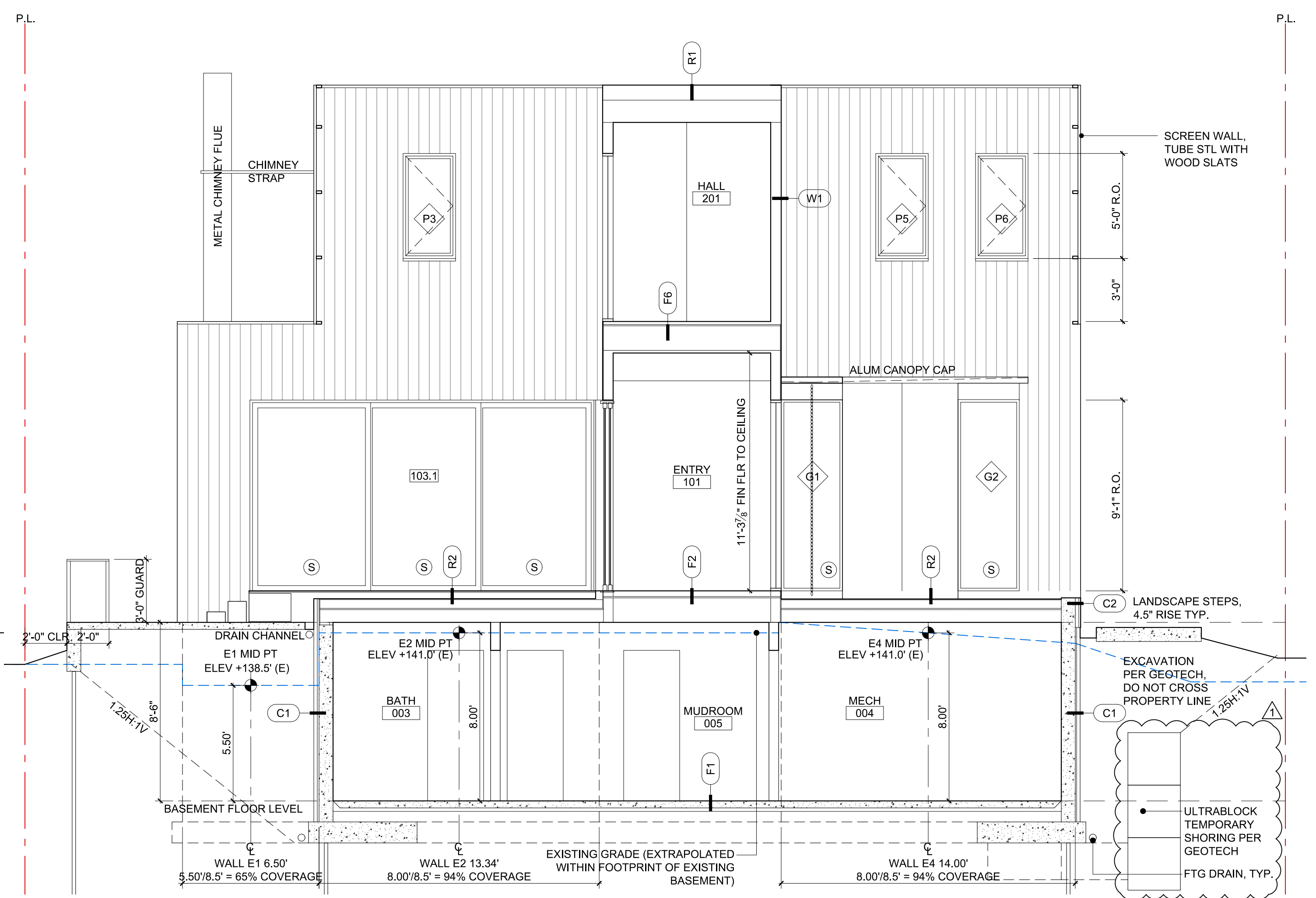

2 BUILDING SECTION | COURTYARD WEST ELEVATION
1/4" = 1'-0"

BUILDING PERMIT SUBMITTAL	JAN. 18, 2023
BUILDING PERMIT CORRECTION 1	JULY 7, 2023

Jurisdiction Review

Owner Name
SAM FRANKLIN + JUNE CADENHEAD
Project Address
3064 68TH AVE SE
MERCER ISLAND, WA 98040

Sheet Information	
Job Number	2209
Drawn	DR / TL
Checked	SB
Title	
BUILDING SECTIONS	

Sheet

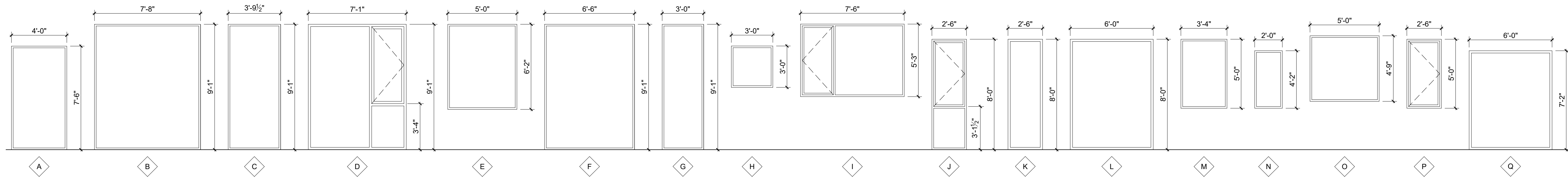

3064 68TH AVE SE
BUILDING PERMIT SUBMITTAL

1 GRAPHIC WINDOW SCHEDULE
1/4" = 1'-0"

WINDOW SCHEDULE: BASIS OF DESIGN - MARVIN SIGNATURE MODERN AND ESSENTIAL

MARK	ROOM NUMBER	R.O. WIDTH (in.)	R.O. HEIGHT (in.)	MATL.	TYPE	GLASS	REMARKS	QA	U-VALUE	AREA (SF)	U*AREA
A	002	48.00	90.00	FIBERGLASS	PICTURE	SG	MARVIN ESSENTIAL	1	0.28	30.0	8.40
B	103	92.00	109.00	FIBERGLASS	PICTURE	SG	MARVIN SIGNATURE MODERN	2	0.28	139.3	78.00
C	103	45.50	109.00	FIBERGLASS	PICTURE	SG	MARVIN SIGNATURE MODERN	1	0.28	34.4	9.64
D	103	85.00	109.00	FIBERGLASS	CASEMENT-PICT COMBO	SG	MARVIN SIGNATURE MODERN	1	0.28	64.3	18.02
E	102	60.00	74.00	FIBERGLASS	PICTURE	SG	MARVIN SIGNATURE MODERN	1	0.28	30.8	8.63
F	101	78.00	109.00	FIBERGLASS	PICTURE	SG	MARVIN SIGNATURE MODERN	1	0.28	59.0	16.53
G	102	36.00	109.00	FIBERGLASS	PICTURE	SG	MARVIN SIGNATURE MODERN	2	0.28	54.5	30.52
H	107	36.00	36.00	FIBERGLASS	PICTURE	SG	MARVIN ESSENTIAL	1	0.28	9.0	2.52
I	104	90.00	63.00	FIBERGLASS	CASEMENT-PICT COMBO	SG	MARVIN ESSENTIAL	1	0.28	39.4	11.03
J	201, 207, 208, 209	30.00	96.00	FIBERGLASS	CASEMENT-PICT COMBO	SG	MARVIN ESSENTIAL, EGRESS PER PLAN LOCATIONS	5	0.28	100.0	140.00
K	201	30.00	96.00	FIBERGLASS	PICTURE	SG	MARVIN ESSENTIAL	1	0.28	20.0	5.60
L	201	72.00	96.00	FIBERGLASS	PICTURE	SG	MARVIN ESSENTIAL	3	0.28	144.0	120.96
M	210	40.00	60.00	FIBERGLASS	PICTURE	SG	MARVIN ESSENTIAL	1	0.28	16.7	4.67
N	205	24.00	50.00	FIBERGLASS	PICTURE	SG	MARVIN ESSENTIAL	1	0.28	8.3	2.33
O	001	60.00	57.00	FIBERGLASS	PICTURE	SG	MARVIN ESSENTIAL	1	0.28	23.8	6.65
P	107, 202, 203, 205, 206, 211	30.00	60.00	FIBERGLASS	CASEMENT	SG	MARVIN ESSENTIAL	6	0.28	75.0	126.00
Q	202	72.00	86.00	FIBERGLASS	PICTURE	SG	MARVIN ESSENTIAL	1	0.28	43.0	12.04
WINDOW TOTAL								30		891.6	601.53
WINDOW AVERAGE U-VALUE									0.280		

WINDOW | DOOR NOTES

- ALL UNITS DRAWN AS VIEWED FROM THE EXTERIOR.
- REFER TO ELEVATIONS FOR SAFETY GLAZING LOCATIONS.
- ALL GLAZING IN EXTERIOR DOORS TO BE SAFETY GLAZING.
- ALL WINDOW DIMENSIONS ON GRAPHIC SCHEDULE ARE ROUGH OPENING DIMENSIONS, U.N.O.
- ALL EXTERIOR DOOR DIMENSIONS ON GRAPHIC SCHEDULE ARE ROUGH OPENING DIMENSIONS, U.N.O.
- VERTICAL DIMENSION OF EXTERIOR DOOR ROUGH OPENING IS MEASURED FROM BOTTOM OF SILL FRAME.
- PROVIDE SPACE BELOW EXTERIOR DOOR SILL FRAMES FOR FLASHING, AS REQUIRED.
- ALIGN TOP OF DOOR FRAME WITH TOP OF ADJACENT WINDOW FRAMES, AT ALL LOCATIONS.
- CONFIRM SCREEN REQ'S AT OPERABLE UNITS WITH OWNER.

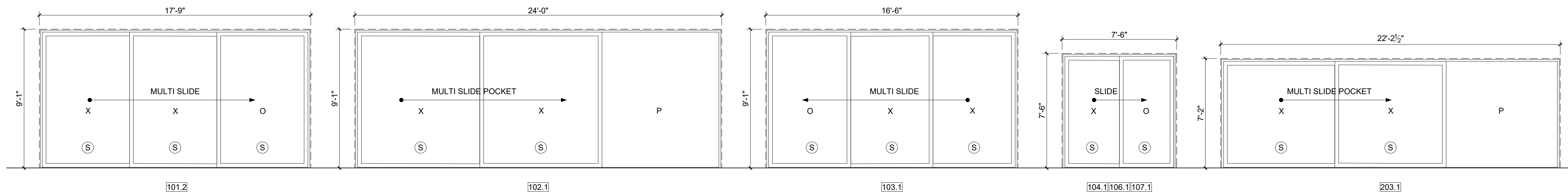
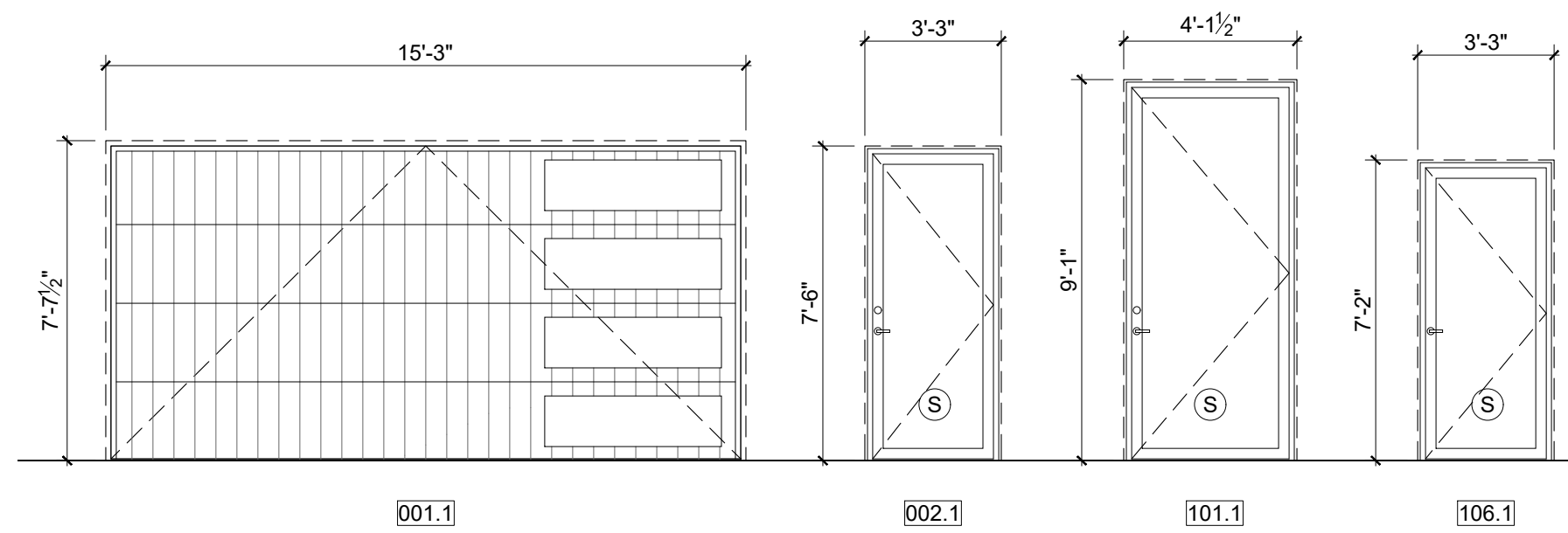

2 GRAPHIC DOOR SCHEDULE
1/4" = 1'-0"

DOOR SCHEDULE - EXTERIOR

NO.	LOCATION	R.O. WIDTH	R.O. HEIGHT	SWING	THICK.	FRAME	HARDWARE	MATL.	REMARKS	QA	U-VALUE	AREA (SF)	U*AREA
001.1	GARAGE	15'-3"	7'-7 1/2"	OVRHD	-	-	-	-	INSULATED, WOOD SIDING, 1.5 HP MIN.	1			
002.1	ADU ENTRY	3'-3"	7'-6"	IN	1 3/4"	4 9/16"	MINIMALIST	FIBERGLASS	MARVIN SIGNATURE MODERN, SG	1	0.28	24.4	6.83
101.1	MAIN ENTRY	4'-0"	9'-1"	IN	1 3/4"	4 9/16"	MINIMALIST	FIBERGLASS	MARVIN SIGNATURE MODERN, SG	1	0.28	36.3	10.16
101.2	ENTRY COURT	17'-9"	9'-1"	M.SLIDE	2 1/4"	10"	MINIMALIST	FIBERGLASS	MARVIN SIGNATURE MODERN, XXO, SG	1	0.28	161.2	45.14
102.1	KITCHEN	24'-0"	9'-1"	M.SLIDE	2 1/4"	7"	MINIMALIST	FIBERGLASS	MARVIN SIGNATURE MODERN, XXPCKT, SG	1	0.28	140.7	39.40
103.1	LIVING	16'-6"	9'-1"	M.SLIDE	2 1/4"	10"	MINIMALIST	FIBERGLASS	MARVIN SIGNATURE MODERN, OXX, SG	1	0.28	149.8	41.94
104.1	STUDIO	7'-6"	7'-6"	M.SLIDE	2 1/4"	7"	MINIMALIST	FIBERGLASS	MARVIN SIGNATURE MODERN, OX, SG	1	0.28	56.3	15.76
106.1	HALL	7'-6"	7'-6"	M.SLIDE	2 1/4"	7"	MINIMALIST	FIBERGLASS	MARVIN SIGNATURE MODERN, OX, SG	1	0.28	56.3	15.76
107.1	GUEST BED	7'-6"	7'-6"	M.SLIDE	2 1/4"	7"	MINIMALIST	FIBERGLASS	MARVIN SIGNATURE MODERN, OX, SG	1	0.28	56.3	15.76
205.1	BATH	3'-3"	7'-2"	OUT	1 3/4"	4 9/16"	MINIMALIST	FIBERGLASS	MARVIN SIGNATURE MODERN, SG	1	0.28	23.4	6.55
203.1	BEDROOM	22'-2 1/2"	7'-2"	M.SLIDE	2 1/4"	7"	MINIMALIST	FIBERGLASS	MARVIN SIGNATURE MODERN, XXPCKT, SG	1	0.28	108.0	30.24
DOOR TOTAL												812.7	227.56
DOOR AVERAGE U-VALUE											0.280		

DOOR SCHEDULE - INTERIOR

NO.	LOCATION	PANEL WIDTH	PANEL HEIGHT	THICKNESS	TYPE	HARDWARE	MATL.	REMARKS	QA
001.2	GARAGE	2'-8"	7'-0"	1-3/8"	SOLID CORE	SECURITY	WD, PTD	20 MIN. GASKETED SEALS & SPRING HINGES	1
002.2	ADU	2'-8"	7'-0"	1-3/8"	SOLID CORE	PRIVACY	WD, PTD	GASKETED ACOUSTIC SEALS	1
003.1	ADU BATH	2'-8"	7'-0"	1-3/8"	SOLID CORE	PRIVACY	WD, PTD	GASKETED ACOUSTIC SEALS	1
003.2	ADU BATH	2'-8"	7'-0"	1-3/8"	SOLID CORE	PRIVACY	WD, PTD	GASKETED ACOUSTIC SEALS	1
004.1	MECHANICAL	2'-8"	7'-0"	1-3/8"	SOLID CORE	PASSAGE	WD, PTD	GASKETED ACOUSTIC SEALS	1
104.2	STUDIO	2'-8"	7'-0"	1-3/8"	SOLID CORE	PRIVACY	WD, PTD		1
105.1	POWDER	2'-8"	7'-0"	1-3/8"	SOLID CORE	PRIVACY	WD, PTD		1
107.2	GUEST BEDROOM	2'-8"	7'-0"	1-3/8"	SOLID CORE	PRIVACY	WD, PTD		1
107.3	GUEST BATH	2'-8"	7'-0"	1-3/8"	SOLID CORE	PRIVACY	WD, PTD	POCKET SLIDER	1
202.1	STUDY	3'-0"	8'-0"	1-3/4"	SOLID CORE	PRIVACY	WD, PTD	POCKET SLIDER	1
203.2	BEDROOM	3'-6"	8'-0"	1-3/4"	SOLID CORE	PRIVACY	WD, PTD	POCKET SLIDER	1
205.2	BATHROOM	3'-0"	8'-0"	1-3/4"	SOLID CORE	PRIVACY	WD, PTD	POCKET SLIDER	1
206.1	LAUNDRY	2'-8"	7'-0"	1-3/8"	SOLID CORE	PASSAGE	WD, PTD		1
207.1	BEDROOM	2'-8"	7'-0"	1-3/8"	SOLID CORE	PRIVACY	WD, PTD		1
208.1	BEDROOM	2'-8"	7'-0"	1-3/8"	SOLID CORE	PRIVACY	WD, PTD		1
209.1	BEDROOM	2'-8"	7'-0"	1-3/8"	SOLID CORE	PRIVACY	WD, PTD		1
210.1	WATERCLOSET	2'-6"	7'-0"	1-3/8"	SOLID CORE	PRIVACY	WD, PTD	POCKET SLIDER	1
211.1	BATHROOM	2'-6"	7'-0"	1-3/8"	SOLID CORE	PRIVACY	WD, PTD	POCKET SLIDER	1

BUILDING PERMIT SUBMITTAL
JAN 18, 2023
BUILDING PERMIT CORRECTION 1
JULY 7, 2023

Jurisdiction Review

Owner Name
SAM FRANKLIN + JUNE CADENHEAD
Project Address
3064 68TH AVE SE
MERCER ISLAND, WA 98040

Sheet Information
Job Number 2209
Drawn DR / TL
Checked SB

WINDOW AND DOOR SCHEDULES

Sheet

A900

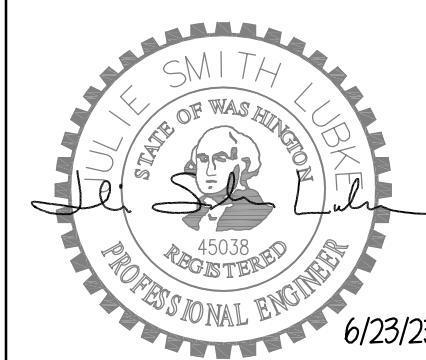

GENERAL STRUCTURAL NOTES

(THE FOLLOWING APPLY UNLESS SHOWN OTHERWISE ON THE PLANS)

CRITERIA

- ALL MATERIALS, WORKMANSHIP, DESIGN, AND CONSTRUCTION SHALL CONFORM TO THE DRAWINGS, SPECIFICATIONS, THE INTERNATIONAL BUILDING CODE (2018 EDITION).
- DESIGN LOADING CRITERIA:

FLOOR LIVE LOAD (RESIDENTIAL) 40 PSF
FLOOR LIVE LOAD (RESIDENTIAL DECK) 60 PSF
ROOF SNOW LOAD (Pf) 25 PSF

WIND:

BASIC WIND SPEED (3-SECOND GUST) 98 MPH
WIND RISK CATEGORY II
WIND EXPOSURE C
TOPOGRAPHICAL FACTOR (Kzt) 1.00

EARTHQUAKE:

LAT. / LONG. 47.582 / -122.247
SEISMIC IMPORTANCE FACTOR (Ie) 1.0
SEISMIC RISK CATEGORY II
SEISMIC SITE CLASS D
MAPPED SPECTRAL RESPONSE (Ss/S1) 1.41g/0.49g
SPECTRAL RESPONSE COEF. (SDS/SD1) 0.94g/0.59g
SEISMIC FORCE RESISTING SYSTEM: . . PLYWOOD SHEAR WALLS
DESIGN BASE SHEAR 31.59k
SEISMIC RESPONSE COEFFICIENT (Cs) 0.144
SEISMIC DESIGN CATEGORY D
RESPONSE MODIFICATION FACTOR (R) 6.5
ANALYSIS PROCEDURE EQUIVALENT LATERAL FORCE

REFERENCE: ASCE 7 HAZARDS REPORT

- STRUCTURAL DRAWINGS SHALL BE USED IN CONJUNCTION WITH ARCHITECTURAL DRAWINGS FOR BIDDING AND CONSTRUCTION. CONTRACTOR SHALL VERIFY DIMENSIONS AND CONDITIONS FOR COMPATIBILITY AND SHALL NOTIFY ARCHITECT OF ANY DISCREPANCIES PRIOR TO CONSTRUCTION.
- CONTRACTOR SHALL VERIFY ALL EXISTING CONDITIONS PRIOR TO COMMENCING ANY WORK AND DETERMINE THE LOCATION OF ALL ADJACENT UNDERGROUND UTILITIES PRIOR TO COMMENCING EXCAVATION, AND NOTIFY ARCHITECT OF DISCREPANCIES AND CONFLICTS.
- CONTRACTOR SHALL PROVIDE TEMPORARY BRACING FOR THE STRUCTURE AND STRUCTURAL COMPONENTS UNTIL ALL FINAL CONNECTIONS HAVE BEEN COMPLETED IN ACCORDANCE WITH THE PLANS.
- CONTRACTOR SHALL BE RESPONSIBLE FOR ALL SAFETY PRECAUTIONS AND THE METHODS, TECHNIQUES, SEQUENCES OR PROCEDURES REQUIRED TO PERFORM THE WORK. THE STRUCTURAL ENGINEER HAS NO OVERALL SUPERVISORY AUTHORITY OR ACTUAL AND/OR DIRECT RESPONSIBILITY FOR THE SPECIFIC WORKING CONDITIONS AT THE SITE AND/OR FOR ANY HAZARDS RESULTING FROM THE ACTIONS OF ANY TRADE CONTRACTOR. THE STRUCTURAL ENGINEER HAS NO DUTY TO INSPECT, SUPERVISE, NOTE, CORRECT, OR REPORT ANY HEALTH OR SAFETY DEFICIENCIES OF THE OWNER, CONTRACTORS, OR OTHER ENTITIES OR PERSONS AT THE PROJECT SITE.
- SPECIAL INSPECTION OF THE FOLLOWING TYPES OF CONSTRUCTION SHALL BE PROVIDED IN ACCORDANCE WITH SECTIONS 110 AND 1704 OF THE INTERNATIONAL BUILDING CODE AND THE PROJECT SPECIFICATIONS BY A QUALIFIED TESTING AGENCY DESIGNATED BY THE ARCHITECT, AND RETAINED BY THE BUILDING OWNER. THE ARCHITECT, STRUCTURAL ENGINEER, AND BUILDING DEPARTMENT SHALL BE FURNISHED WITH COPIES OF ALL INSPECTION AND TEST RESULTS.

- STRUCTURAL STEEL FABRICATION AND ERECTION (INCLUDING FIELD WELDING AND HIGH-STRENGTH FIELD BOLTING)
- EXPANSION BOLTS AND THREADED EXPANSION INSERTS
- EPOXY GROUTED INSTALLATIONS
- DRIVEN PILE INSTALLATION

- SHOP DRAWINGS FOR THE FOLLOWING ITEMS SHALL BE SUBMITTED TO THE ARCHITECT AND STRUCTURAL ENGINEER FOR REVIEW PRIOR TO FABRICATION OF THESE ITEMS.

- STRUCTURAL STEEL

APPROVED SETS OF ALL SHOP DRAWINGS SHALL ALSO BE SUBMITTED TO THE BUILDING DEPARTMENT.

GEOTECHNICAL

- FOUNDATION NOTES: SUBGRADE PREPARATION INCLUDING DRAINAGE, EXCAVATION, COMPACTION, AND FILLING REQUIREMENTS, SHALL CONFORM STRICTLY WITH RECOMMENDATIONS GIVEN IN THE SOILS REPORT OR AS DIRECTED BY THE SOILS ENGINEER. FOOTINGS SHALL BEAR ON SOLID UNDISTURBED EARTH (CONTROLLED, COMPACTED STRUCTURAL FILL OR BOTH) AT LEAST 18" BELOW LOWEST ADJACENT FINISHED GRADE. FOOTING DEPTHS/ELEVATIONS SHOWN ON PLANS (OR IN DETAILS) ARE MINIMUM AND FOR GUIDANCE ONLY; THE ACTUAL ELEVATIONS OF FOOTINGS MUST BE ESTABLISHED BY THE CONTRACTOR IN THE FIELD WORKING WITH THE TESTING LAB AND SOILS ENGINEER. BACKFILL BEHIND ALL RETAINING WALLS WITH FREE DRAINING GRANULAR FILL AND PROVIDE FOR SUBSURFACE DRAINAGE AS NOTED IN THE SOILS REPORT.

ALLOWABLE SOIL PRESSURE NA PSF
ACTIVE EARTH PRESSURE (LEVEL GROUND BEHIND WALLS) 35 PCF
AT-REST EARTH PRESSURE (LEVEL GROUND BEHIND WALLS) 45 PCF

SOILS REPORT REFERENCE: GEO GROUP NORTHWEST NO. G-5713

- PIPE PILE INSTALLATION SHALL CONFORM STRICTLY WITH THE RECOMMENDATIONS GIVEN IN THE SOILS REPORT OR AS DIRECTED BY THE SOILS ENGINEER. INSPECTION OF PILE INSTALLATION BY THE SOILS ENGINEER IS REQUIRED. PIPE PILES SHALL BE DRIVEN TO REFUSAL, WHERE REFUSAL IS DEFINED AS THE MINIMUM NUMBER OF SECONDS REQUIRED TO ACHIEVE ONE INCH OF PENETRATION, AS INDICATED BELOW:

HAMMER MODEL	HAMMER WEIGHT	REFUSAL CRITERIA
TB225	650 LB	12 SEC/INCH
TB325	850 LB	10 SEC/INCH

PIPE PILE AXIAL CAPACITY IS 6 TONS (12,000 LB).

PIPE PILES SHALL BE 3" DIAMETER, SCHEDULE 40 (0.216" WALL), AND SHALL CONFORM TO ASTM A53, GRADE A, FY = 30 KSI. PILES SHALL BE TESTED PER GEOTECHNICAL RECOMMENDATIONS.

CONCRETE

- CONCRETE SHALL BE MIXED, PROPORTIONED, CONVEYED AND PLACED IN ACCORDANCE WITH IBC SECTION 1905 AND ACI 301. CONCRETE SHALL ATTAIN A 28-DAY STRENGTH OF F'c = 2,500 PSI AND MIX SHALL CONTAIN NOT LESS THAN 5-1/2 SACKS OF CEMENT PER CUBIC YARD AND SHALL BE PROPORTIONED TO PRODUCE A SLUMP OF 5" OR LESS.

THE MINIMUM AMOUNTS OF CEMENT AND MAXIMUM AMOUNTS OF WATER MAY BE CHANGED IF A CONCRETE PERFORMANCE MIX IS SUBMITTED TO THE STRUCTURAL ENGINEER AND THE BUILDING DEPARTMENT FOR APPROVAL TWO WEEKS PRIOR TO PLACING ANY CONCRETE. THE CONCRETE PERFORMANCE MIX SHALL INCLUDE THE AMOUNTS OF CEMENT, FINE AND COARSE AGGREGATE, WATER AND ADMIXTURES AS WELL AS THE WATER CEMENT RATIO, SLUMP, CONCRETE YIELD AND SUBSTANTIATING STRENGTH DATA IN ACCORDANCE WITH IBC 1905.3. REVIEW OF MIX SUBMITTALS BY THE ENGINEER OF RECORD INDICATES ONLY THAT INFORMATION PRESENTED CONFORMS GENERALLY WITH CONTRACT DOCUMENTS. CONTRACTOR OR SUPPLIER MAINTAINS FULL RESPONSIBILITY FOR SPECIFIED PERFORMANCE.

ALL CONCRETE WITH SURFACES EXPOSED TO STANDING WATER SHALL BE AIR-ENTRAINED WITH AN AIR-ENTRAINING AGENT CONFORMING TO ASTM C260, C494, AND C618. TOTAL AIR CONTENT SHALL BE IN ACCORDANCE WITH TABLE 1904.2.1 OF THE INTERNATIONAL BUILDING CODE.

- REINFORCING STEEL SHALL CONFORM TO ASTM A615 (INCLUDING SUPPLEMENT S1), GRADE 60, FY = 60,000 PSI. WELDED WIRE FABRIC SHALL CONFORM TO ASTM A-185.
- REINFORCING STEEL SHALL BE DETAILED (INCLUDING HOOKS AND BENDS) IN ACCORDANCE WITH ACI 318-14. LAP ALL CONTINUOUS REINFORCEMENT 40 BAR DIAMETERS OR 2'-0" MINIMUM. PROVIDE CORNER BARS AT ALL WALL AND FOOTING INTERSECTIONS. LAP CORNER BARS 40 BAR DIAMETERS OR 2'-0" MINIMUM. LAP ADJACENT MATS OF WELDED WIRE FABRIC A MINIMUM OF 8" AT SIDES AND ENDS.
- CONCRETE PROTECTION (COVER) FOR REINFORCING STEEL SHALL BE AS FOLLOWS:
A. FOOTINGS AND OTHER UNFORMED SURFACES, EARTH FACE 3"
B. ALL OTHER SURFACES 1 1/2"

- NON-SHRINK GROUT SHALL BE FURNISHED BY AN APPROVED MANUFACTURER AND SHALL BE MIXED AND PLACED IN STRICT ACCORDANCE WITH THE MANUFACTURER'S PUBLISHED RECOMMENDATIONS. GROUT STRENGTH SHALL BE AT LEAST EQUAL TO THE MATERIAL ON WHICH IT IS PLACED (3000 PSI MINIMUM).

ANCHORAGE

- EXPANSION BOLTS INTO CONCRETE AND GROUTED MASONRY UNITS SHALL BE "STRONG-BOLT" ANCHORS AS MANUFACTURED BY THE SIMPSON COMPANY AND INSTALLED IN STRICT ACCORDANCE WITH ICC ER 1771, INCLUDING MINIMUM EMBEDMENT REQUIREMENTS.

- EPOXY-GROUTED ITEMS SPECIFIED ON THE DRAWINGS SHALL BE GROUTED WITH "SET-XP" HIGH STRENGTH EPOXY AS MANUFACTURED BY THE SIMPSON COMPANY AND INSTALLED IN STRICT ACCORDANCE WITH ICC ESR 2508.

STEEL

- STRUCTURAL STEEL DESIGN, FABRICATION, AND ERECTION SHALL BE BASED ON THE LATEST EDITIONS OF THE AISC SPECIFICATIONS AND CODES:

- SPECIFICATION FOR STRUCTURAL STEEL BUILDINGS-ALLOWABLE STRESS DESIGN.
- CODE OF STANDARD PRACTICE FOR STEEL BUILDINGS AND BRIDGES, AMENDED BY THE DELETION OF THE FOLLOWING SENTENCE IN PARAGRAPH 4.2.1: "THIS APPROVAL CONSTITUTES THE OWNER'S ACCEPTANCE OF ALL RESPONSIBILITY FOR THE DESIGN ADEQUACY OF ANY DETAIL CONFIGURATION OF CONNECTIONS DEVELOPED BY THE FABRICATOR AS PART OF HIS PREPARATION OF THESE SHOP DRAWINGS."
- SPECIFICATION FOR STRUCTURAL JOINTS USING ASTM A325 OR A490 BOLTS. BOLTS IN SHEAR OR BEARING TYPE CONNECTIONS NEED ONLY BE TIGHTENED TO THE SNUG TIGHT CONDITION PER SECTION 8(C).

- STRUCTURAL STEEL SHALL CONFORM TO THE FOLLOWING MINIMUM STANDARDS. PLATES, ANGLES, AND CHANNELS SHALL CONFORM TO ASTM A36, FY = 36 KSI. WIDE FLANGE SHAPES SHALL CONFORM TO ASTM A992, FY = 50 KSI. STEEL PIPE SHALL CONFORM TO ASTM A53, TYPE E OR S, GRADE B, FY = 35 KSI. SQUARE OR RECTANGULAR STRUCTURAL TUBING SHALL CONFORM TO ASTM A500, GRADE B, FY = 46 KSI. ANCHOR BOLTS AND CONNECTION BOLTS SHALL CONFORM TO ASTM A307.

- ALL WELDING SHALL BE IN CONFORMANCE WITH AISC AND AWS STANDARDS AND SHALL BE PERFORMED BY WABO CERTIFIED WELDERS USING E70XX ELECTRODES. ONLY PREQUALIFIED WELDS (AS DEFINED BY AWS) SHALL BE USED.

WOOD

- FRAMING LUMBER SHALL BE KILN DRIED OR MC-15, AND GRADED AND MARKED IN CONFORMANCE WITH WCLIB STANDARD GRADING RULES FOR WEST COAST LUMBER NO. 17, LATEST EDITION. FURNISH TO THE FOLLOWING MINIMUM STANDARDS:

JOISTS: (2X MEMBERS)	HEM-FIR NO. 2 MINIMUM BASE VALUE, FB = 850 PSI
(3X & 4X MEMBERS)	DOUGLAS FIR NO. 1 MINIMUM BASE VALUE, FB = 1000 PSI

STRUCTURAL LIGHT FRAMING: (INCL. 3X AND 4X POSTS)	DOUGLAS FIR NO. 2 MINIMUM BASE VALUE, FB = 900 PSI
--	---

BEAMS AND STRINGERS: (INCL. 6X AND LARGER)	DOUGLAS FIR NO. 1 MINIMUM BASE VALUE, FB = 1350 PSI
---	--

POSTS AND TIMBERS: (6X6 AND LARGER)	DOUGLAS FIR NO. 1 MINIMUM BASE VALUE, FC = 1000 PSI
--	--

STUDS, PLATES & MISC. FRAMING:	DOUGLAS FIR OR HEM-FIR STANDARD GRADE
--------------------------------	---------------------------------------

2X6 STUDS AND PLATES:	HEM-FIR NO. 3/ STUD GRADE
-----------------------	---------------------------

2X AND 3X T & G DECKING	HEM-FIR COMMERCIAL DEX, MINIMUM BASE VALUE, FB = 1350 PSI
-------------------------	--

- ENGINEERED LUMBER MEMBERS SHALL BE MANUFACTURED UNDER A PROCESS BY THE NATIONAL RESEARCH BOARD. EACH PIECE SHALL BEAR A STAMP OR STAMPS NOTING THE NAME AND PLANT NUMBER OF THE MANUFACTURER, THE GRADE, THE NATIONAL RESEARCH BOARD NUMBER, AND THE QUALITY CONTROL AGENCY. ALL LUMBER SHALL BE MANUFACTURED IN ACCORDANCE WITH THE APPROPRIATE NER REPORT AND GLUED WITH A WATERPROOF ADHESIVE MEETING THE REQUIREMENTS OF ASTM D2559 WITH ALL GRAIN PARALLEL WITH THE LENGTH OF THE MEMBER.

PSL	FB = 2900 PSI	E = 2000 KSI	FV = 290 PSI	NER-292
LSL	FB = 2250 PSI	E = 1500 KSI	FV = 285 PSI	NER-481
LVL	FB = 2600 PSI	E = 1800 KSI	FV = 285 PSI	NER-126

DESIGN SHOWN ON PLANS IS BASED ON LUMBER MANUFACTURED BY THE WEYERHAUSER CORPORATION. ALTERNATE MANUFACTURERS MAY BE USED SUBJECT TO REVIEW AND APPROVAL BY THE ARCHITECT AND STRUCTURAL ENGINEER. ALTERNATE JOIST HANGERS AND OTHER HARDWARE MAY BE SUBSTITUTED FOR ITEMS SHOWN PROVIDED THEY HAVE ICC APPROVAL FOR EQUAL OR GREATER LOAD CAPACITIES. ALL JOIST HANGERS AND OTHER HARDWARE SHALL BE COMPATIBLE IN SIZE WITH MEMBERS PROVIDED.

ALL PROPOSED HOLE SIZES AND LOCATIONS SHALL BE SUBMITTED TO THE STRUCTURAL ENGINEER FOR APPROVAL TWO WORKING DAYS PRIOR TO DRILLING HOLES.

- PREFABRICATED PLYWOOD WEB JOIST DESIGN SHOWN ON PLANS IS BASED ON JOISTS MANUFACTURED BY THE WEYERHAUSER CORPORATION AND SHALL BE FURNISHED AND INSTALLED IN CONFORMANCE WITH THE MANUFACTURER'S PUBLISHED SPECIFICATIONS. ALL NECESSARY BRIDGING, BLOCKING, BLOCKING PANELS, STIFFENERS, ETC., SHALL BE DETAILED AND FURNISHED BY THE MANUFACTURER. SUBMIT SHOP DRAWINGS TO THE ARCHITECT AND STRUCTURAL ENGINEER FOR REVIEW PRIOR TO FABRICATION. ALTERNATE PLYWOOD WEB JOIST MANUFACTURERS MAY BE USED SUBJECT TO REVIEW AND APPROVAL BY THE ARCHITECT AND STRUCTURAL ENGINEER. ALTERNATE JOIST HANGERS AND OTHER HARDWARE MAY BE SUBSTITUTED FOR ITEMS SHOWN PROVIDED THEY HAVE ICC APPROVAL FOR EQUAL OR GREATER LOAD CAPACITIES. ALL JOIST HANGERS AND OTHER HARDWARE SHALL BE COMPATIBLE IN SIZE WITH PLYWOOD WEB JOIST PROVIDED.

ALL HOLES SHALL CONFORM TO THE MANUFACTURERS SPECIFICATIONS. IF THREE OR FEWER HOLES ARE PROPOSED FOR A SINGLE JOIST, HOLES SHALL CONFORM TO THE WEYERHAUSER ILEVEL TJI ALLOWABLE HOLE CHART. IF MORE THEN THREE HOLES ARE PROPOSED FOR ONE SINGLE JOIST, ALL HOLE SIZES AND LOCATIONS SHALL BE SUBMITTED TO THE STRUCTURAL ENGINEER FOR APPROVAL TWO WORKING DAYS PRIOR TO DRILLING HOLES.

- PLYWOOD SHEATHING SHALL BE GRADE C-D, EXTERIOR GLUE OR STRUCTURAL II, EXTERIOR GLUE IN CONFORMANCE WITH APA STANDARDS. ORIENTED STRAND BOARD OF EQUIVALENT THICKNESS, EXPOSURE RATING AND SPAN RATING MAY BE USED IN LIEU OF PLYWOOD.

- ROOF SHEATHING SHALL BE 1/2" (NOM.) WITH SPAN RATING 24/0.
- FLOOR SHEATHING SHALL BE 3/4" (NOM.) WITH SPAN RATING 40/20.
- WALL SHEATHING SHALL BE 1/2" (NOM.) WITH SPAN RATING 24/0.

REFER TO WOOD FRAMING NOTES BELOW FOR TYPICAL NAILING.

- ALL WOOD IN DIRECT CONTACT WITH CONCRETE OR MASONRY SHALL BE PRESSURE-TREATED WITH AN APPROVED PRESERVATIVE OR (2) LAYERS OF ASPHALT IMPREGNATED BUILDING PAPER SHALL BE PROVIDED BETWEEN UNTREATED WOOD AND CONCRETE OR MASONRY. ALL WOOD EXPOSED TO WEATHER WITHOUT THE ADEQUATE PROTECTION OF A ROOF OR EAVE SHALL BE AN APPROVED WOOD OF NATURAL RESISTANCE TO DECAY OR PRESSURE TREATED. SUCH MEMBERS INCLUDE HORIZONTAL MEMBERS SUCH AS GIRDERS, JOISTS, AND DECKING; OR VERTICAL MEMBERS SUCH AS POSTS, POLES, AND COLUMNS.

- TIMBER CONNECTORS CALLED OUT BY LETTERS AND NUMBERS SHALL BE "STRONG-TIE" BY SIMPSON COMPANY, AS SPECIFIED IN THEIR MOST RECENT CATALOG. EQUIVALENT DEVICES BY OTHER MANUFACTURERS MAY BE SUBSTITUTED, PROVIDED THEY HAVE ICC APPROVAL FOR EQUAL OR GREATER LOAD CAPACITIES. PROVIDE NUMBER AND SIZE OF FASTENERS AS SPECIFIED BY MANUFACTURER. CONNECTORS SHALL BE INSTALLED IN ACCORDANCE WITH THE MANUFACTURER'S RECOMMENDATIONS. WHERE CONNECTOR STRAPS CONNECT TWO MEMBERS, PLACE ONE-HALF OF THE NAILS OR BOLTS IN EACH MEMBER. ALL BOLTS IN WOOD MEMBERS SHALL CONFORM TO ASTM A307. PROVIDE WASHERS UNDER THE HEADS AND NUTS OF ALL BOLTS AND LAG SCREWS BEARING ON WOOD. UNLESS NOTED OTHERWISE, ALL NAILS SHALL BE COMMON. ALL SHIMS SHALL BE SEASONED AND DRIED AND THE SAME GRADE (MINIMUM) AS MEMBERS CONNECTED. HANGERS IN DIRECT CONTACT WITH PRESERVATIVE-TREATED WOOD SHALL BE EITHER STAINLESS STEEL (SST300), POST HOT-DIPPED GALVANIZED(HDG) OR GALVANIZED WITH A MINIMUM OF 1.850Z ZINC PER SQUARE INCH (ZMAX). UNLESS NOTED OTHERWISE, ALL LUMBER JOISTS SHALL BE CONNECTED TO FLUSH BEAMS WITH "LUS" SERIES JOIST HANGERS, AND ALL TJI JOISTS SHALL BE CONNECTED TO FLUSH BEAMS WITH "TIT" OR "IUT" SERIES JOIST HANGERS.

- WOOD FASTENERS

- NAIL SIZES SPECIFIED ON DRAWINGS ARE BASED ON THE FOLLOWING SPECIFICATIONS:

SIZE	LENGTH	DIAMETER
6D	2"	0.113"
8D	2-1/2"	0.131"
10D	3"	0.148"
12D	3-1/4"	0.148"
16D	3-1/2"	0.162"

IF CONTRACTOR PROPOSES THE USE OF ALTERNATE NAILS, THEY SHALL SUBMIT NAIL SPECIFICATIONS TO THE STRUCTURAL ENGINEER (PRIOR TO CONSTRUCTION) FOR REVIEW AND APPROVAL.

- STAPLES - THE FOLLOWING STAPLES MAY BE SUBSTITUTED FOR NAILING OF PLYWOOD (APA RATED SHEATHING):

NAIL SIZE	EQUIV. STAPLE	MINIMUM LENGTH
6D	16 GA.	1-3/4"
8D	15 GA.	1-3/4"
10D	13 GA.	1-3/4"

IF CONTRACTOR PROPOSES THE USE OF ALTERNATE STAPLES, THEY SHALL SUBMIT STAPLE SPECIFICATIONS TO THE STRUCTURAL ENGINEER (PRIOR TO CONSTRUCTION) FOR REVIEW AND APPROVAL.

- NAILS AND STAPLES - PLYWOOD (APA RATED SHEATHING) FASTENERS TO FRAMING SHALL BE DRIVEN FLUSH TO FACE OF SHEATHING WITH NO COUNTER-SINKING PERMITTED.

Sam + June
Mercer Island
3064 - 68th Avenue SE
Mercer Island, WA

Issue Date	Issue Description
1/17/23	Permit
6/24/23	Building Revisions

S1.0
GENERAL STRUCTURAL
NOTES

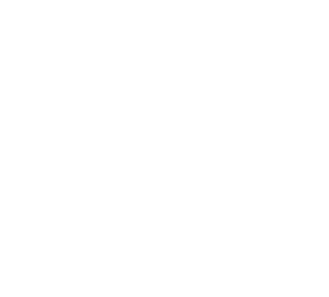

28. TONGUE AND GROOVE STRUCTURAL ROOF AND FLOOR DECKING SHALL BE INSTALLED AS FOLLOWS: 2X DECKING SHALL BE TOENAILED THROUGH THE TONGUE AND FACENAILED WITH ONE 16D NAIL PER PIECE PER SUPPORT. 3X AND 4X DECKING SHALL BE TOENAILED WITH ONE 40D NAIL AND FACENAILED WITH ONE 60D NAIL PER SUPPORT. COURSES SHALL BE SPIKED TOGETHER WITH 8" SPIKES AT 30" O. C. (MAXIMUM) AND AT 10" (MAXIMUM) FROM EACH END OF EACH PIECE. SPIKES SHALL BE INSTALLED IN PREDRILLED EDGE HOLES.

29. WOOD FRAMING NOTES--THE FOLLOWING APPLY UNLESS OTHERWISE SHOWN:

- A. ALL WOOD FRAMING DETAILS NOT SHOWN OTHERWISE SHALL BE CONSTRUCTED TO THE MINIMUM STANDARDS OF THE INTERNATIONAL BUILDING CODE. MINIMUM NAILING, UNLESS OTHERWISE NOTED, SHALL CONFORM TO TABLE 2304.9.1 OF THE INTERNATIONAL BUILDING CODE. UNLESS NOTED OTHERWISE, ALL NAILS SHALL BE COMMON. COORDINATE THE SIZE AND LOCATION OF ALL OPENINGS WITH MECHANICAL AND ARCHITECTURAL DRAWINGS. PROVIDE WASHERS UNDER THE HEADS AND NUTS OF ALL BOLTS AND LAG SCREWS BEARING ON WOOD.
- B. WALL FRAMING: ALL STUD WALLS SHOWN AND NOT OTHERWISE NOTED SHALL BE 2X4 STUDS @ 16" O. C. AT INTERIOR WALLS AND 2X6 @ 16" O. C. AT EXTERIOR WALLS. TWO STUDS MINIMUM SHALL BE PROVIDED AT THE END OF ALL WALLS AND AT EACH SIDE OF ALL OPENINGS. TWO 2X8 HEADERS SHALL BE PROVIDED OVER ALL OPENINGS NOT OTHERWISE NOTED. SOLID BLOCKING FOR WOOD COLUMNS SHALL BE PROVIDED THROUGH FLOORS TO SUPPORTS BELOW. WALLS SHALL HAVE A SINGLE BOTTOM PLATE AND A DOUBLE TOP PLATE. END NAIL TOP PLATE TO EACH STUD WITH TWO 16D NAILS, AND TOENAIL OR END NAIL EACH STUD TO BOTTOM PLATE WITH TWO 16D NAILS. FACE NAIL DOUBLE TOP PLATE WITH 16D AT 12" O. C. AND LAP MINIMUM 4'-0" AT JOINTS AND PROVIDE SIX 16D NAILS AT 4" O. C. EACH SIDE OF JOINT. ALL STUD WALLS SHALL HAVE THEIR LOWER WOOD PLATES ATTACHED TO WOOD FRAMING BELOW WITH 16D NAILS AT 12" O. C. STAGGERED OR BOLTED TO CONCRETE WITH 5/8" DIAMETER ANCHOR BOLTS (WITH 7" MINIMUM EMBEDMENT) @ 4'-0" O. C. UNLESS INDICATED OTHERWISE. INDIVIDUAL MEMBERS OF BUILT-UP POSTS SHALL BE NAILED TO EACH OTHER WITH 16D @ 12" O. C. STAGGERED. REFER TO THE PLANS AND SHEAR WALL SCHEDULE FOR REQUIRED SHEATHING AND NAILING. WHEN NOT OTHERWISE NOTED, PROVIDE GYPSUM WALLBOARD ON INTERIOR SURFACES NAILED TO ALL STUDS, TOP AND BOTTOM PLATES AND BLOCKING WITH NAILS AT 7" O. C. USE 5D COOLER NAILS FOR 1/2" GWB AND 6D COOLER NAILS FOR 5/8" GWB. WHEN NOT OTHERWISE NOTED, PROVIDE 1/2" (NOM.) APA RATED SHEATHING (SPAN RATING 24/0) ON EXTERIOR SURFACES NAILED AT ALL PANEL EDGES (BLOCK UNSUPPORTED EDGES), TOP AND BOTTOM PLATES WITH 8D @ 6" O. C. AND TO ALL INTERMEDIATE STUDS AND BLOCKING WITH 8D @ 12" O. C. ALLOW 1/8" SPACING AT ALL PANEL EDGES AND ENDS.
- C. FLOOR AND ROOF FRAMING: PROVIDE DOUBLE JOISTS AROUND ALL OPENINGS IN FLOORS OR ROOFS UNLESS OTHERWISE NOTED. PROVIDE SOLID BLOCKING AT ALL BEARING POINTS. TOENAIL JOISTS TO SUPPORTS WITH TWO 16D NAILS. ATTACH TIMBER JOISTS TO FLUSH HEADERS OR BEAMS WITH METAL JOIST HANGERS IN ACCORDANCE WITH TIMBER CONNECTOR NOTE. NAIL ALL MULTI-JOIST BEAMS TOGETHER WITH 16D @ 12" O. C. STAGGERED. UNLESS OTHERWISE NOTED ON THE PLANS, ROOF AND FLOOR SHEATHING SHALL BE LAID UP WITH STRENGTH AXIS PERPENDICULAR TO SUPPORTS AND NAILED WITH 10D NAILS @ 6" O. C. TO FRAMED PANEL EDGES AND OVER STUD WALLS AS SHOWN ON PLANS AND @ 12" O. C. TO INTERMEDIATE SUPPORTS. PROVIDE APPROVED PLYWOOD EDGE CLIPS CENTERED BETWEEN JOISTS/TRUSSES AT UNBLOCKED ROOF SHEATHING EDGES. ALL FLOOR SHEATHING EDGES SHALL HAVE APPROVED TONGUE-AND-GROOVE JOINTS OR SHALL BE SUPPORTED WITH SOLID BLOCKING. ALLOW 1/8" SPACING AT ALL PANEL EDGES AND ENDS OF ALL ROOF AND FLOOR SHEATHING. TOENAIL BLOCKING TO SUPPORTS WITH 16D @ 12" O. C. UNLESS OTHERWISE NOTED. AT BLOCKED FLOOR AND ROOF DIAPHRAGMS PROVIDE FLAT 2X BLOCKING AT ALL UNFRAMED PLYWOOD PANEL EDGES AND NAIL WITH EDGE NAILING SPECIFIED.

SMITH LUBKE
STRUCTURAL DESIGN
Info@smithlubke.com
smithlubke.com
206.852.1536
P.O. Box 30954
Seattle, WA 98113

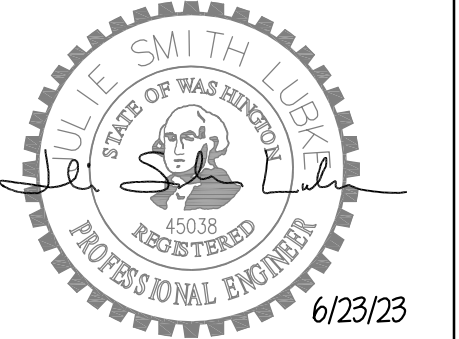

Sam + June
Mercer Island
3064 - 68th Avenue SE
Mercer Island, WA

Issue Date	Issue Description
1/17/23	Permit
6/24/23	Building Revisions

S1.1
GENERAL STRUCTURAL
NOTES

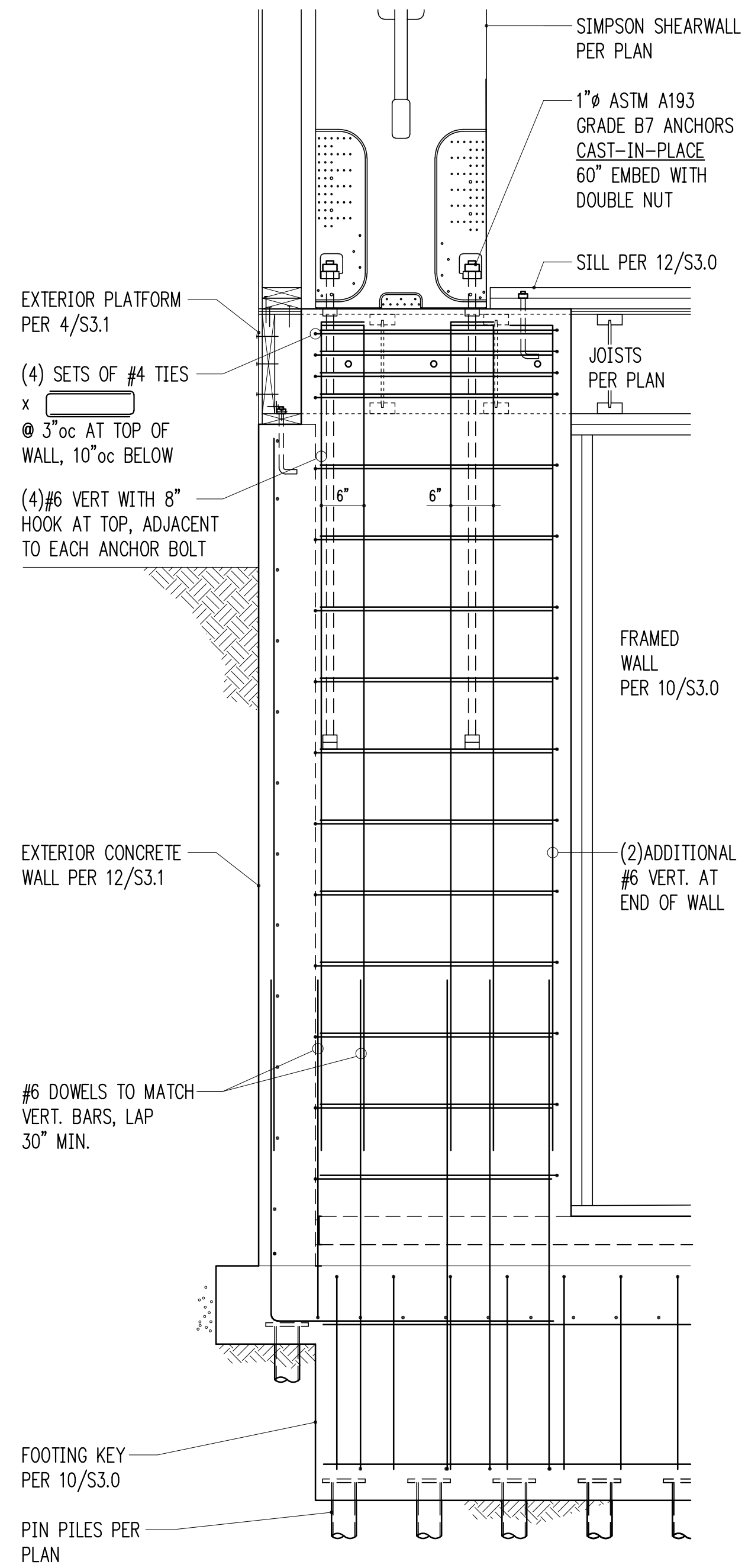

3/4" = 1'-0" 2

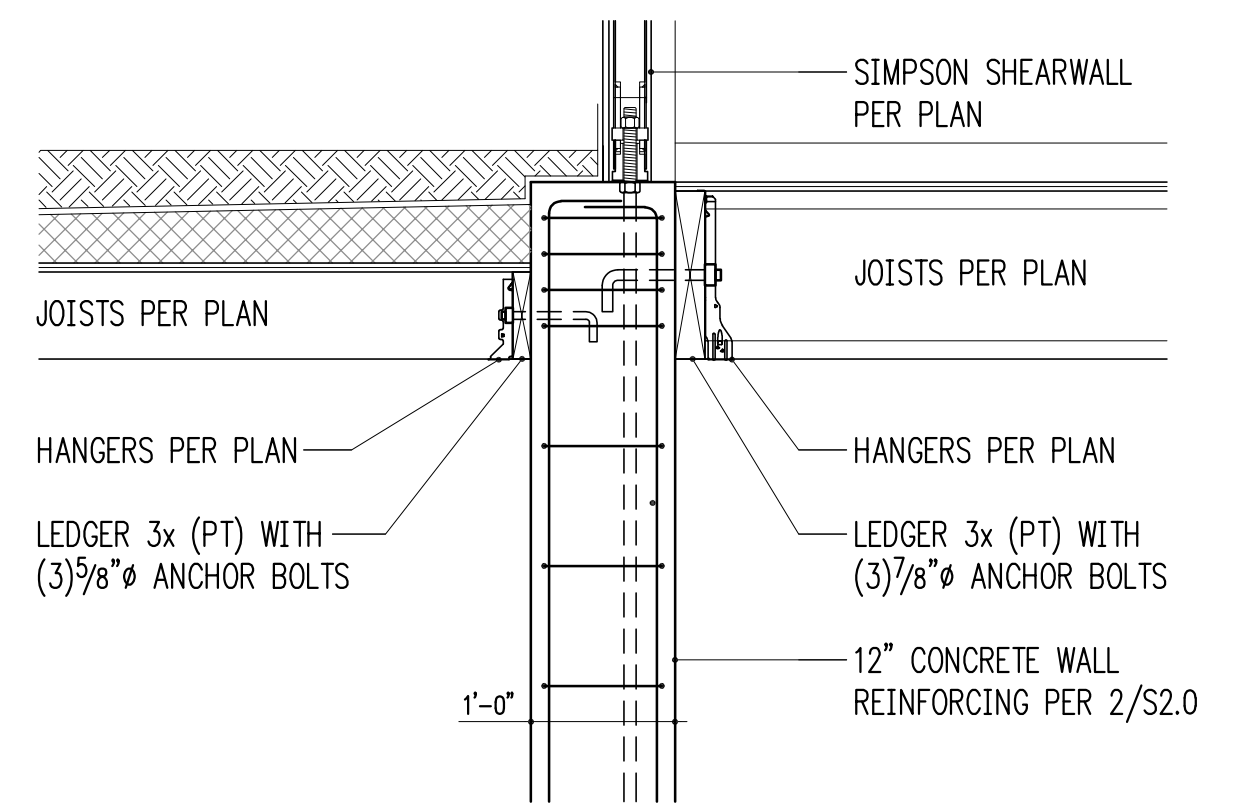

3/4" = 1'-0" 3

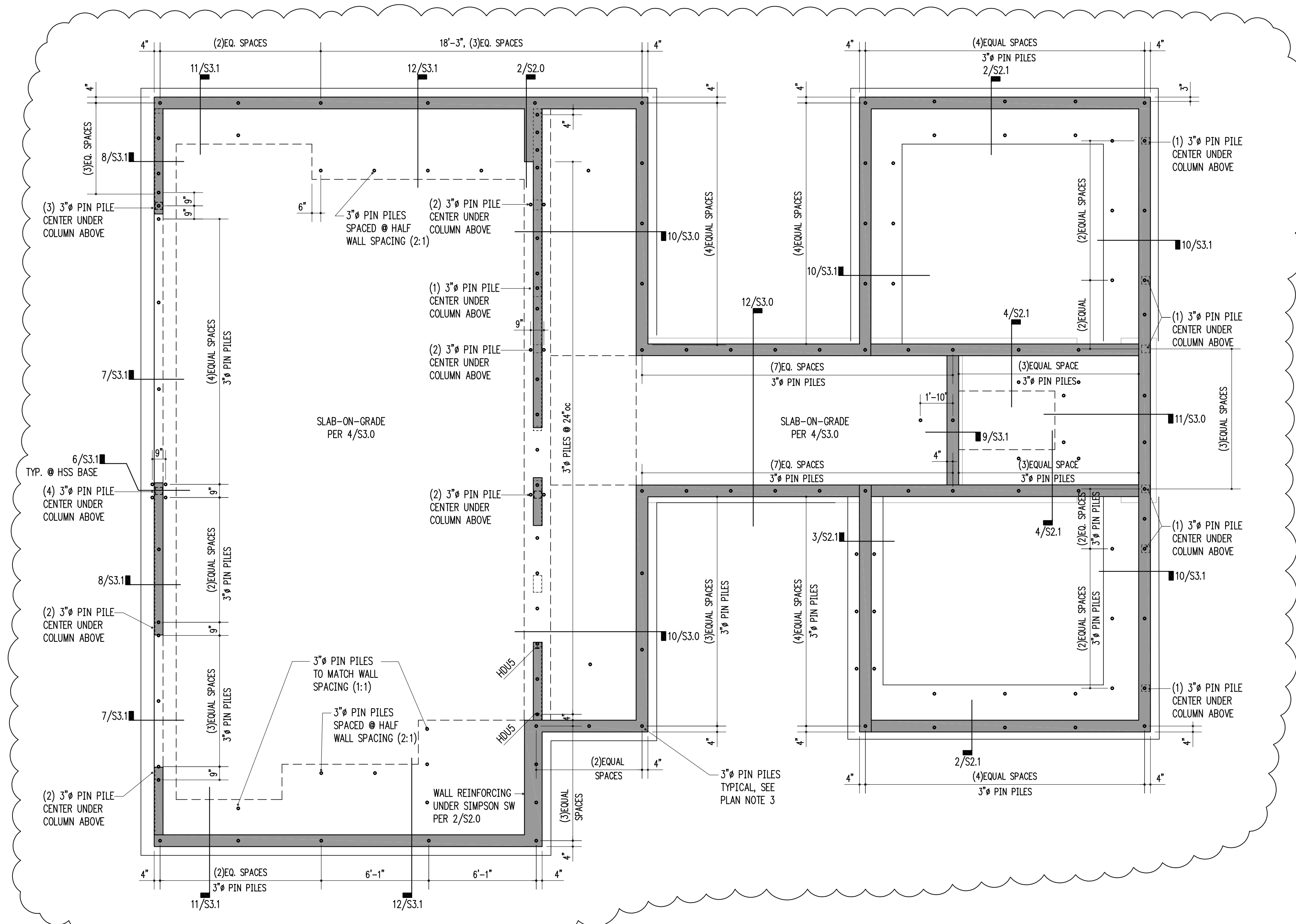

1 LOWER FOUNDATION PLAN
scale: 1/4" = 1'-0"

FOUNDATION PLAN NOTES

- SEE 10/S3.1 FOR TYPICAL HOLDOWN REQUIREMENTS AT CONCRETE WALLS AND FOOTINGS.
- SLAB-ON-GRADE SHALL BE PLACED AND CURED FOR A MINIMUM OF SEVEN DAYS BEFORE RETAINING WALLS ARE BACKFILLED. SEE RETAINING WALL DETAILS FOR SPECIFIC CONFIGURATION.
- 2" PIN PILE SHALL BE INSTALLED PER GENERAL STRUCTURAL NOTES AND DETAIL 3/S3.0.

LEGEND

- SPAN
- EXTENT
- x/S3.0 SECTION DETAIL
- (FB) FLUSH BEAM
- (PT) PRESSURE-TREATED
- COLUMN ABOVE
- COLUMN BELOW
- ⋈ HANGER PER SCHEDULE UNLESS NOTED OTHERWISE
- HD/5 ALL-THREAD HOLDOWN AT END OF SHEARWALL ABOVE
- CS/5 STRAP HOLDOWN AT END OF SHEARWALL ABOVE

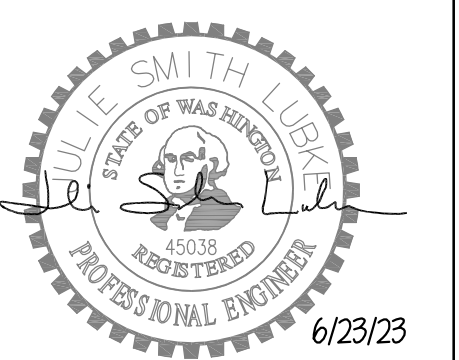

Sam + June
Mercer Island
3064 - 68th Avenue SE
Mercer Island, WA

Issue Date	Issue Description
1/17/23	Permit
6/24/23	Building Revisions

S2.0
LOWER FOUNDATION PLAN

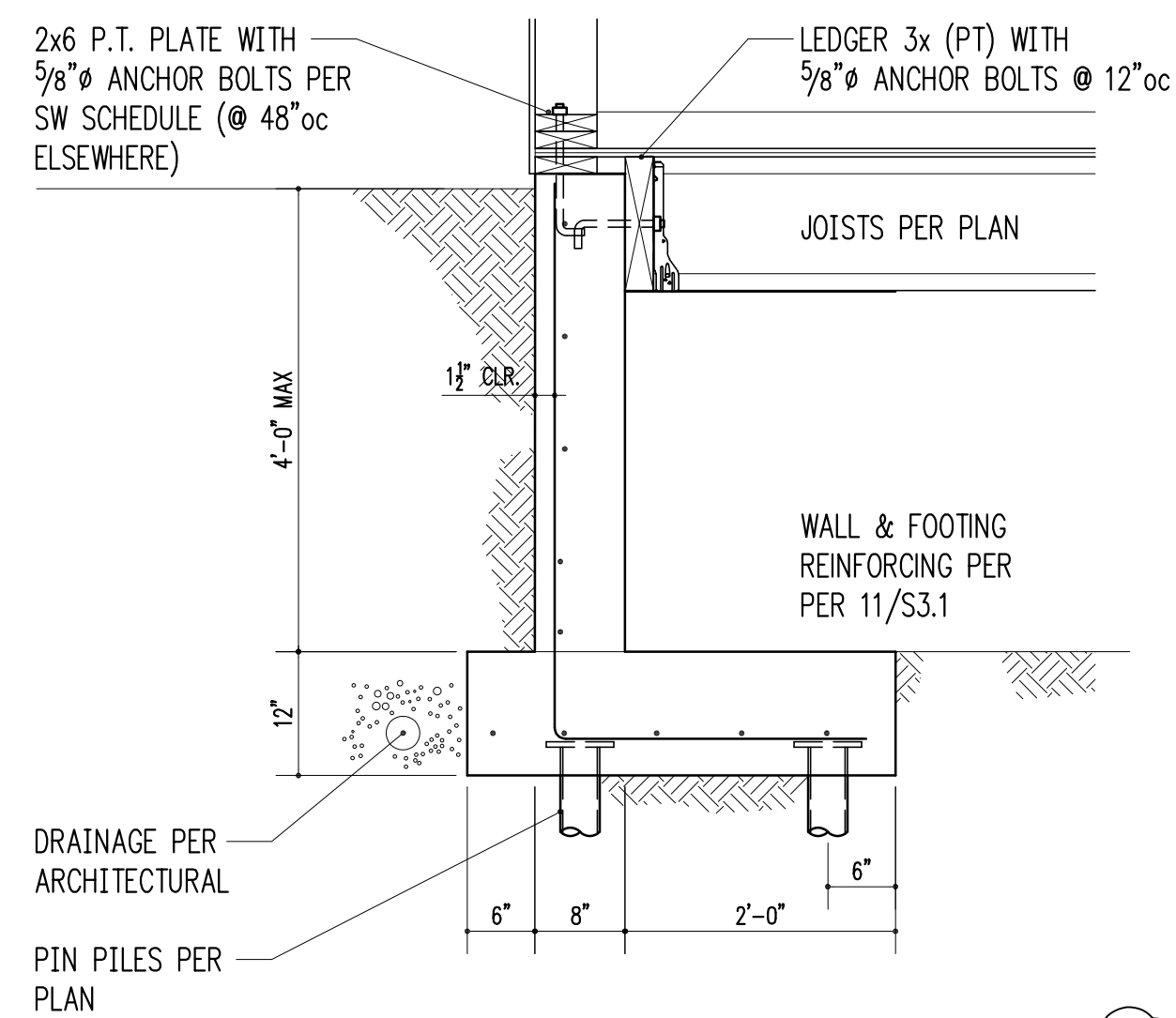

3/4" = 1'-0"

2

WOOD FRAMING CALLOUTS PER 4/S3.1

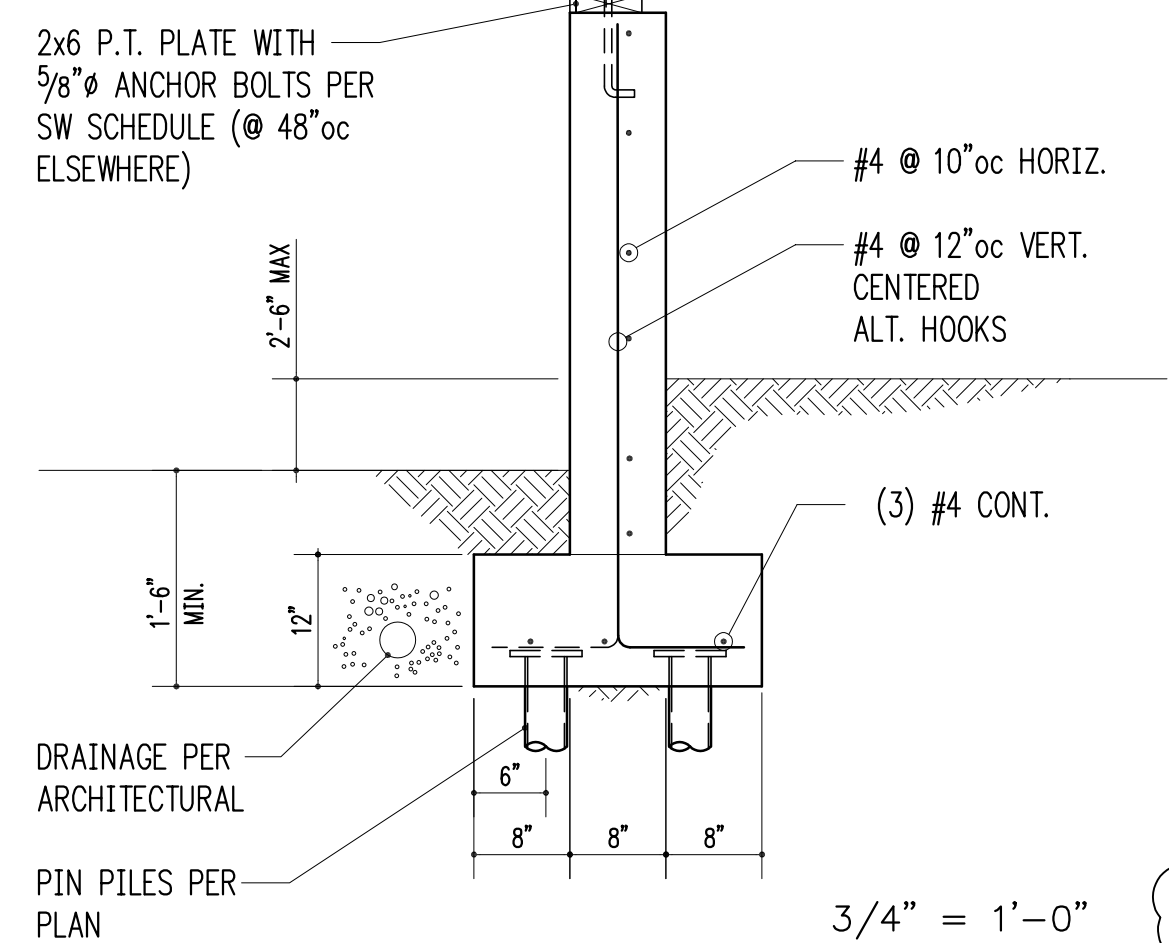

3/4" = 1'-0"

3

SHEARWALL PER PLAN

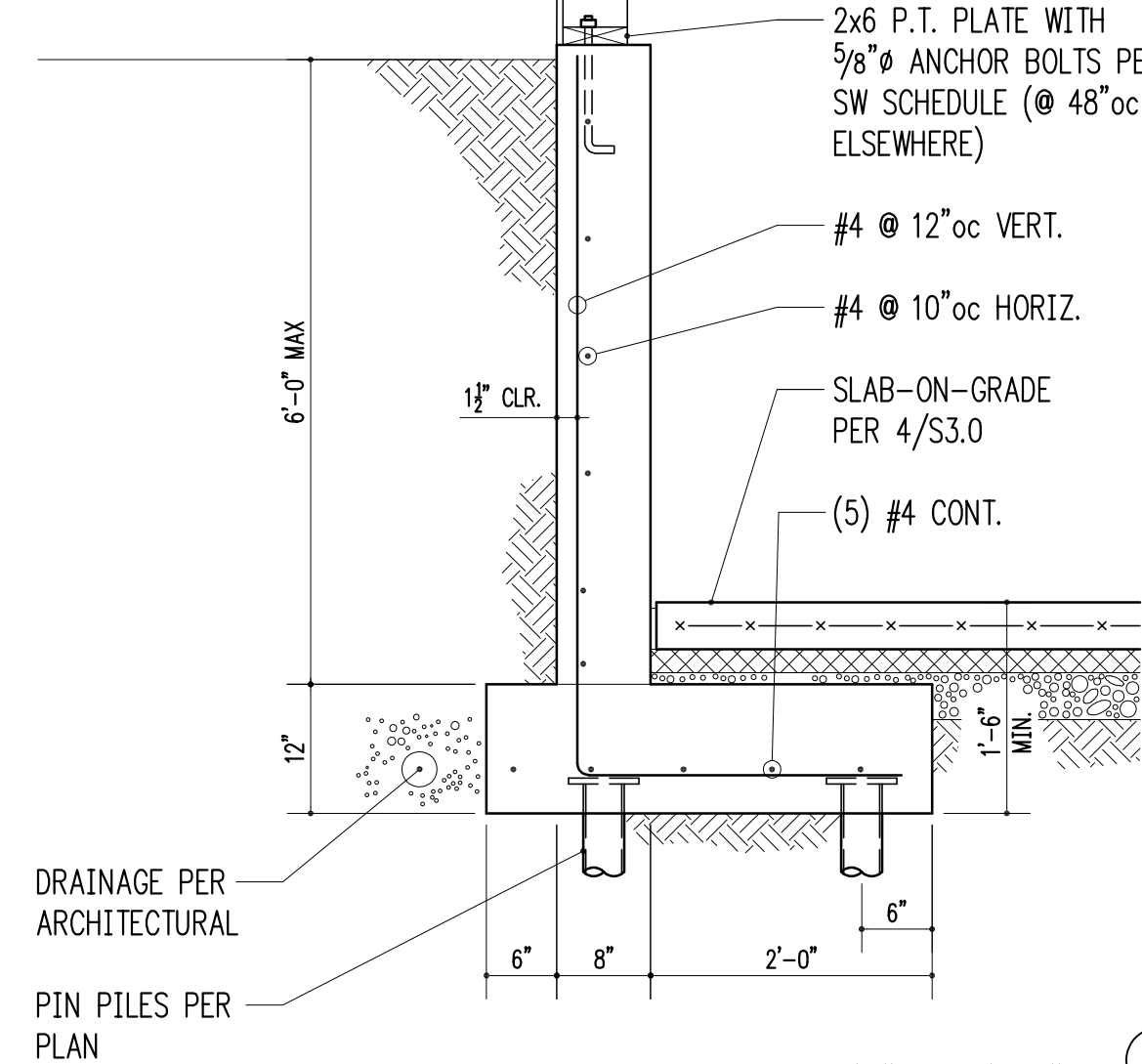

3/4" = 1'-0"

4

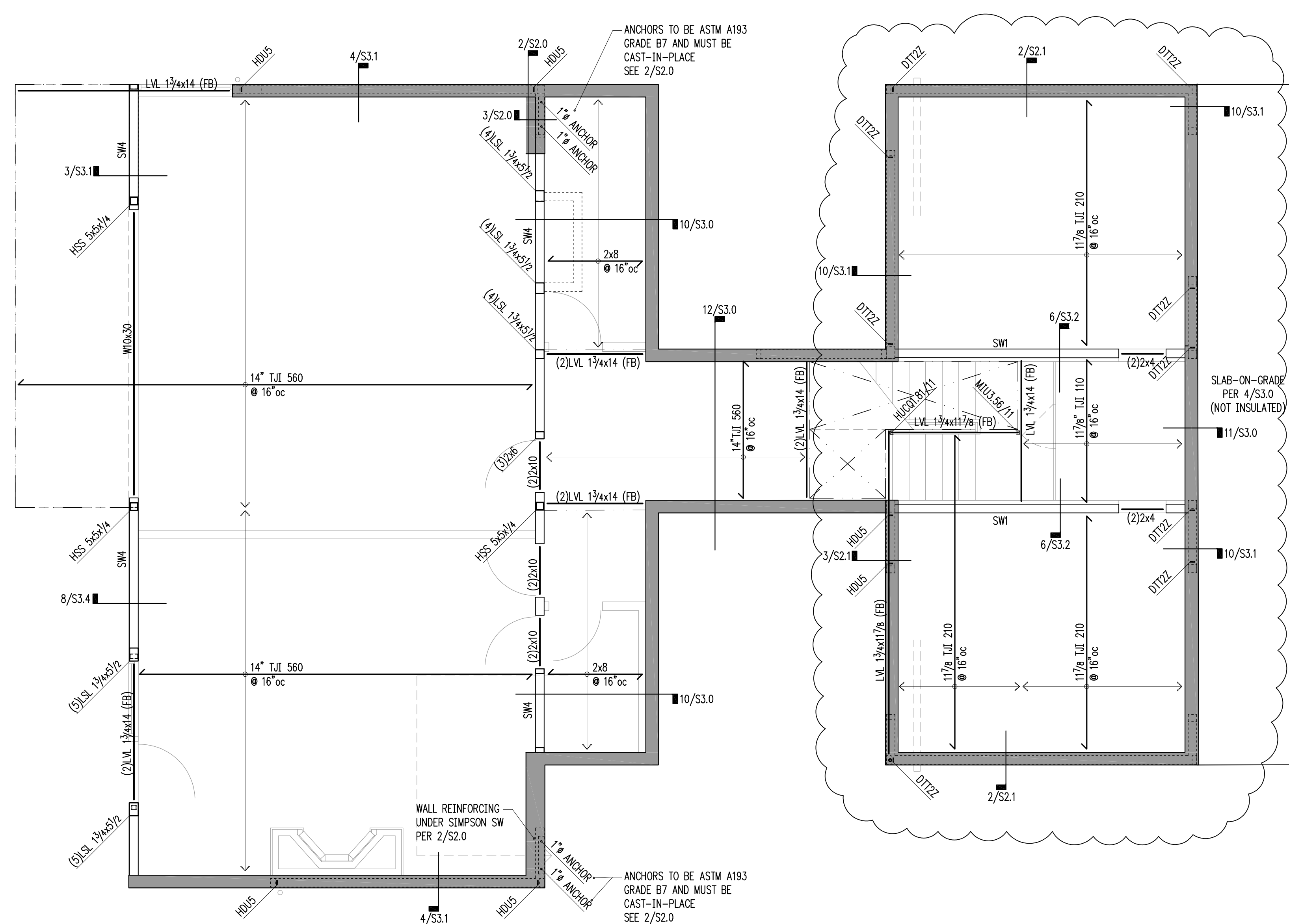

1 MAIN FLOOR FRAMING (BASEMENT WALLS) & UPPER FOUNDATION PLAN
scale: 1/4" = 1'-0"

FRAMING PLAN NOTES

- SW___ INDICATES SHEARWALL TYPE PER SCHEDULE 8/S3.2. REFER TO DETAILS FOR TYPICAL SHEARWALL CONSTRUCTION. SEE ARCHITECTURAL DRAWINGS FOR ADDITIONAL WALL INFORMATION.
- REFER TO GENERAL STRUCTURAL NOTES FOR FLOOR OR ROOF SHEATHING TYPE, THICKNESS, AND NAILING.
- COLUMNS SHALL BE DOUBLE STUD MINIMUM, UNLESS NOTED OTHERWISE. SEE 11/S3.2.
- AT ALL SHEARWALLS PROVIDE DOUBLE TOP PLATES AND SPLICE PER 12/S3.2.

HANGER SCHEDULE

MEMBER (FLAT ONLY)	HANGER	FACE NAILING	MEMBER FASTENERS	WEB STIFF REQUIRED
2x8	LU28	8-10d x 1 1/2	6-10d x 1 1/2	-
LVL 1 3/4x9 1/2	HUS1.81/10	30-10d x 1 1/2	10-10d	-
LVL 1 3/4x11 7/8	HUS1.81/10	30-10d x 1 1/2	10-10d	-
LVL 1 3/4x14	HUS1.81/10	30-10d x 1 1/2	10-10d	-
(2)LVL 1 3/4x14	U414	16-0.162 x 3 1/2	6-0.148 x 3	YES
9 1/2" TJI 110	IUS1.81/9.5	8-10dx1.5	2-STRONG GRIP	-
11 7/8" TJI 210	IUS2.06/11.88	10-10dx1.5	2-STRONG GRIP	-
14" TJI 110	IUS1.81/14	12-10dx1.5	2-STRONG GRIP	-
14" TJI 360	IUS2.37/14	12-10dx1.5	2-STRONG GRIP	-
14" TJI 560	MIUS.56/14	22-10dx1.5	2-10dx1.5	YES
4x16	CJT5Z	10-1/4"x3" SDS	(5) 1/2" x 2 3/4" LONG JOIST PINS	-

LEGEND

- SPAN
- EXTENT
- x/S3.0 SECTION DETAIL
- (FB) FLUSH BEAM
- (PT) PRESSURE-TREATED
- ⋮ COLUMN ABOVE
- COLUMN BELOW
- ⋮ HANGER PER SCHEDULE UNLESS NOTED OTHERWISE
- HOX ALL-THREAD HOLDDOWN AT END OF SHEARWALL ABOVE
- CSX STRAP HOLDDOWN AT END OF SHEARWALL ABOVE

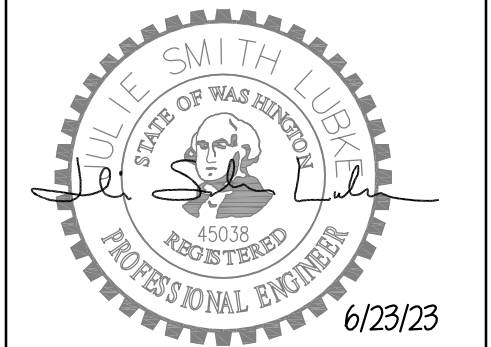

Sam + June
Mercer Island
3064 - 68th Avenue SE
Mercer Island, WA

Issue Date	Issue Description
1/17/23	Permit
6/24/23	Building Revisions

S2.1
MAIN FLOOR FRAMING
& UPPER FOUNDATION
PLAN

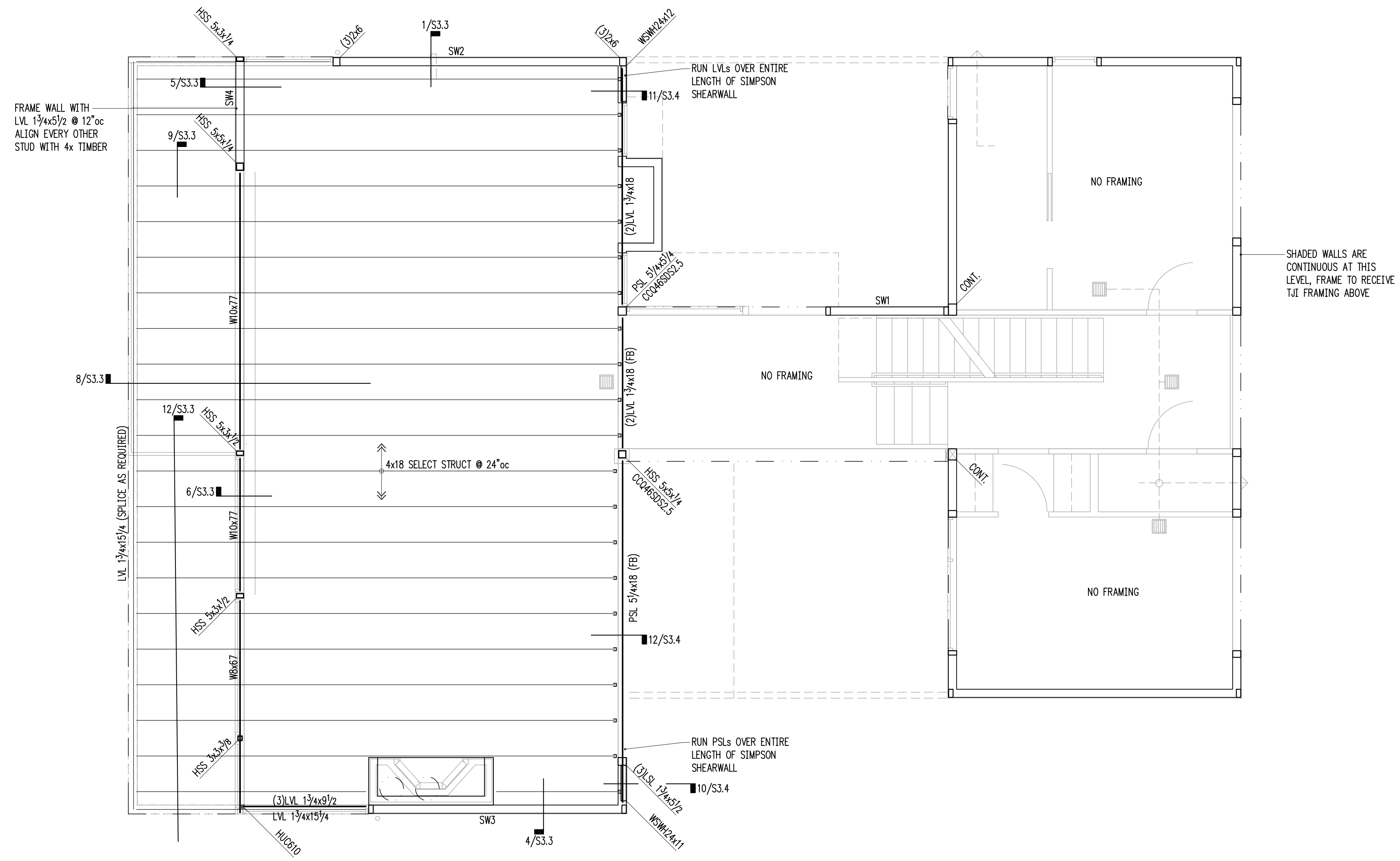
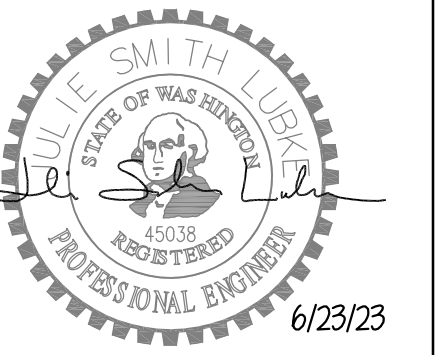

1 MAIN FLOOR CEILING FRAMING PLAN (MAIN FLOOR WALLS)
S2.2 scale: 1/4" = 1'-0"

FRAMING PLAN NOTES

- SW___ INDICATES SHEARWALL TYPE PER SCHEDULE 8/S3.2. REFER TO DETAILS FOR TYPICAL SHEARWALL CONSTRUCTION. SEE ARCHITECTURAL DRAWINGS FOR ADDITIONAL WALL INFORMATION.
- REFER TO GENERAL STRUCTURAL NOTES FOR FLOOR OR ROOF SHEATHING TYPE, THICKNESS, AND NAILING.
- COLUMNS SHALL BE DOUBLE STUD MINIMUM, UNLESS NOTED OTHERWISE. SEE 11/S3.2.
- AT ALL SHEARWALLS PROVIDE DOUBLE TOP PLATES AND SPLICE PER 12/S3.2.

HANGER SCHEDULE

MEMBER (FLAT ONLY)	HANGER	FACE NAILING	MEMBER FASTENERS	WEB STIFF REQUIRED
2x8	LU28	8-10d x 1 1/2	6-10d x 1 1/2	-
LVL 1 3/4 x 9 1/2	HUS1.81/10	30-10d x 1 1/2	10-10d	-
LVL 1 3/4 x 11 7/8	HUS1.81/10	30-10d x 1 1/2	10-10d	-
LVL 1 3/4 x 14	HUS1.81/10	30-10d x 1 1/2	10-10d	-
(2)LVL 1 3/4 x 14	U414	16-0.162 x 3 1/2	6-0.148 x 3	YES
9 1/2" TJI 110	IUS1.81/9.5	8-10dx1.5	2-STRONG GRIP	-
11 7/8" TJI 210	IUS2.06/11.88	10-10dx1.5	2-STRONG GRIP	-
14" TJI 110	IUS1.81/14	12-10dx1.5	2-STRONG GRIP	-
14" TJI 360	IUS2.37/14	12-10dx1.5	2-STRONG GRIP	-
14" TJI 560	MIUS.56/14	22-10dx1.5	2-10dx1.5	YES
4x16	CJT5Z	10-1/4"x3" SDS	(5) 1/2" x 2 3/4" LONG JOIST PINS	-

SIDE OF BLANK TO PLATE

LEGEND

- SPAN
- EXTENT
- x/S3.0 SECTION DETAIL
- (FB) FLUSH BEAM
- (PT) PRESSURE-TREATED
- ⋮ COLUMN ABOVE
- COLUMN BELOW
- ⊘ HANGER PER SCHEDULE UNLESS NOTED OTHERWISE
- ALL-THREAD HOLDOWN AT END OF SHEARWALL ABOVE
- STRAP HOLDOWN AT END OF SHEARWALL ABOVE

Sam + June
Mercer Island
3064 - 68th Avenue SE
Mercer Island, WA

Issue Date	Issue Description
1/17/23	Permit
6/24/23	Building Revisions

S2.2
MAIN FLOOR CEILING FRAMING PLAN

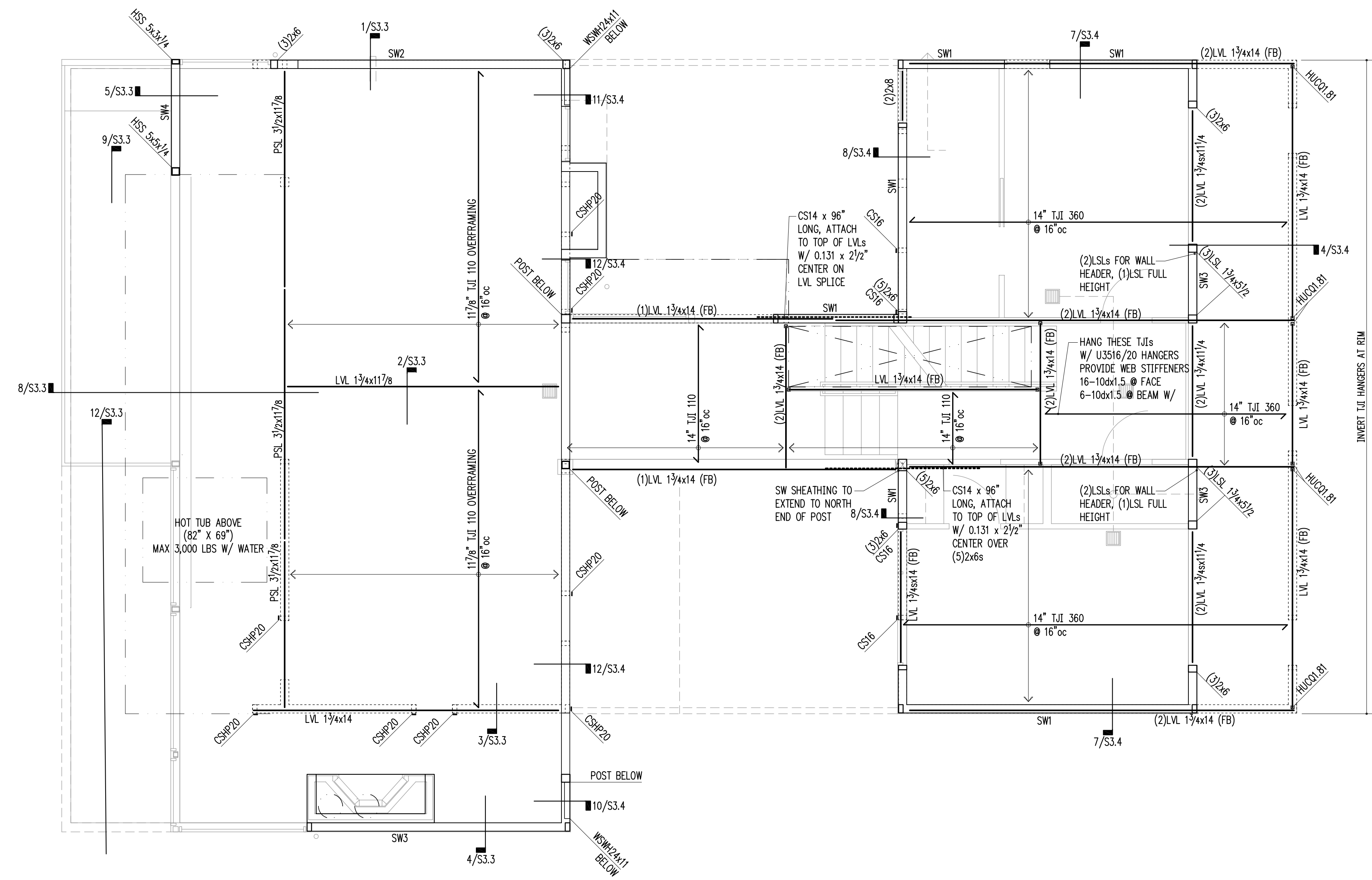
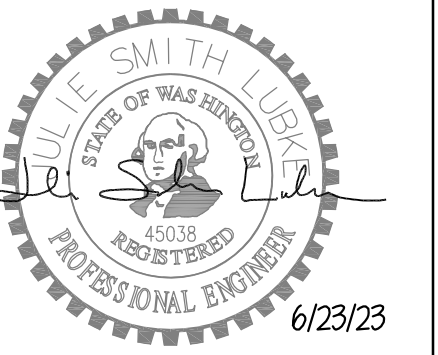

1 UPPER FLOOR FRAMING PLAN (MAIN FLOOR WALLS)
 S2.3 scale: 1/4" = 1'-0"

Sam + June
 Mercer Island
 3064 - 68th Avenue SE
 Mercer Island, WA

Issue Date	Issue Description
1/17/23	Permit
6/24/23	Building Revisions

S2.3
 UPPER FLOOR FRAMING PLAN

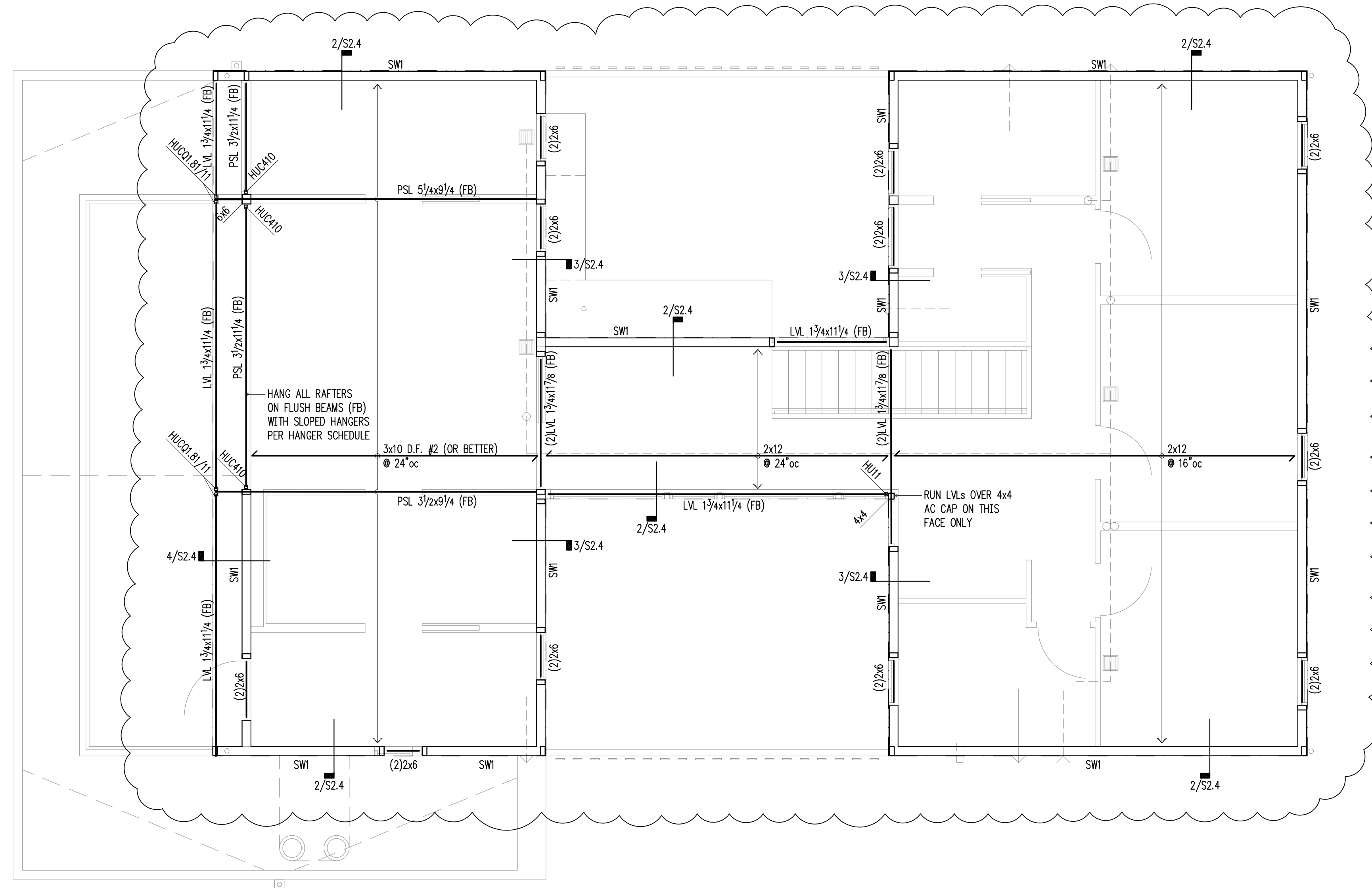
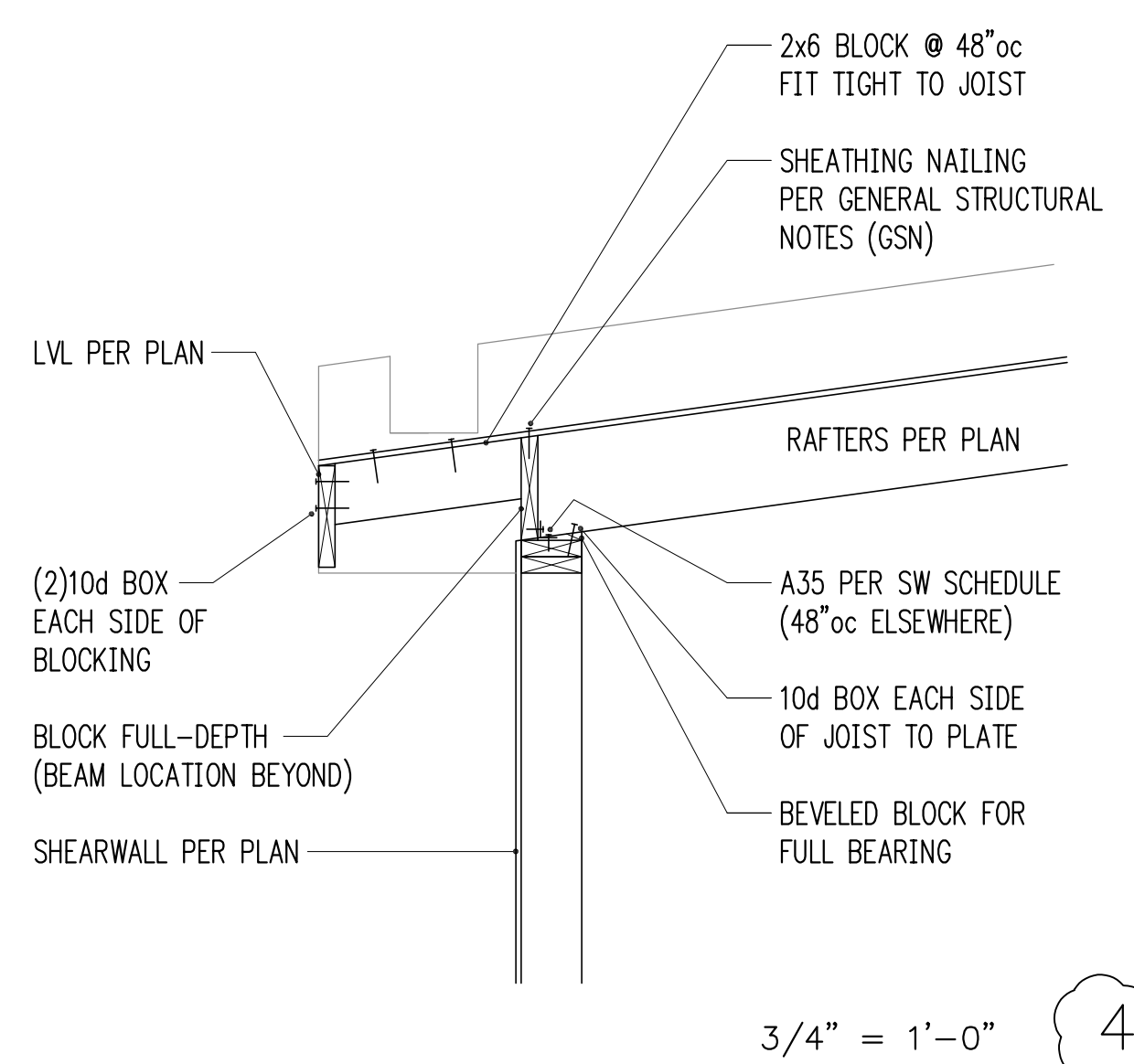
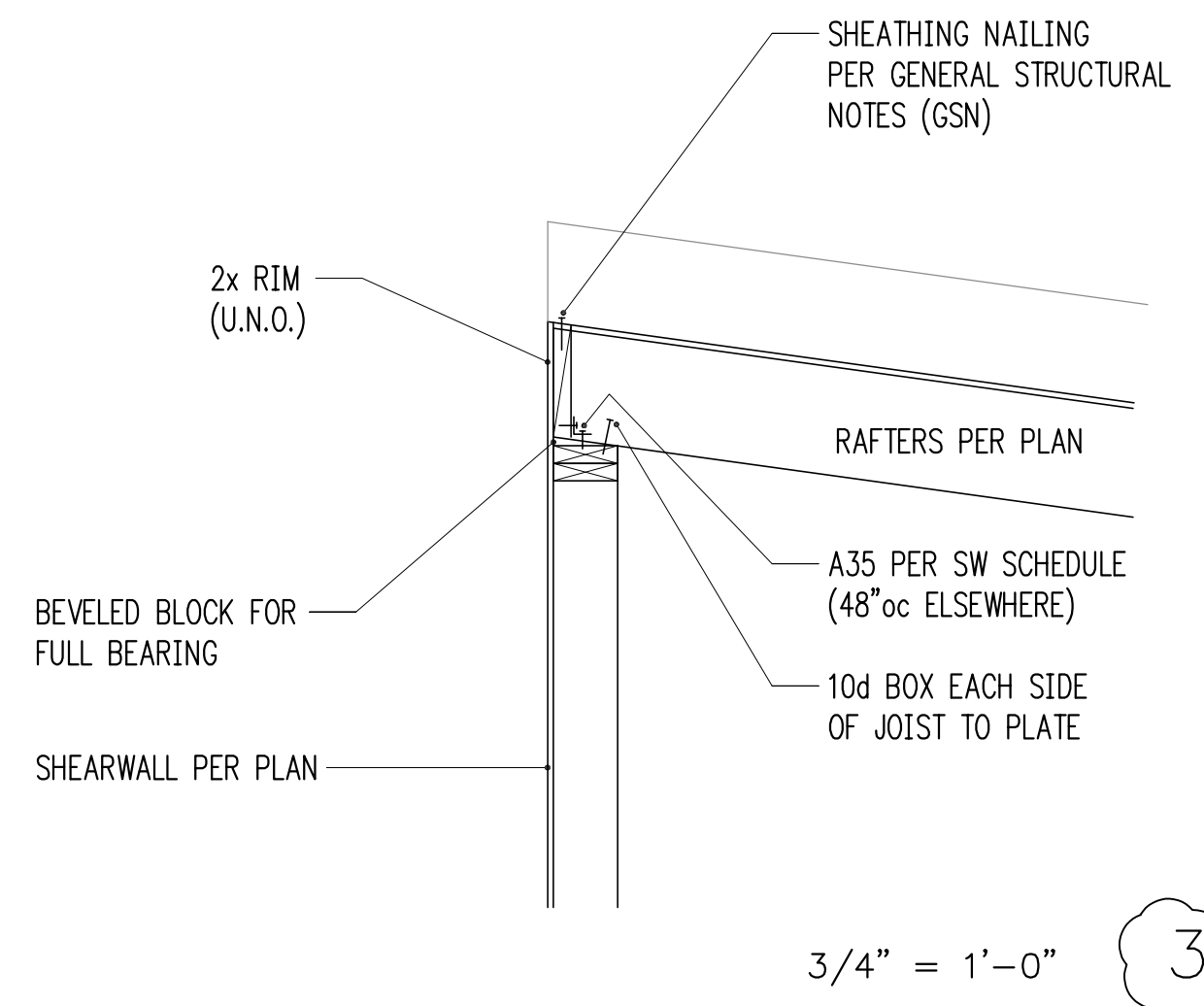
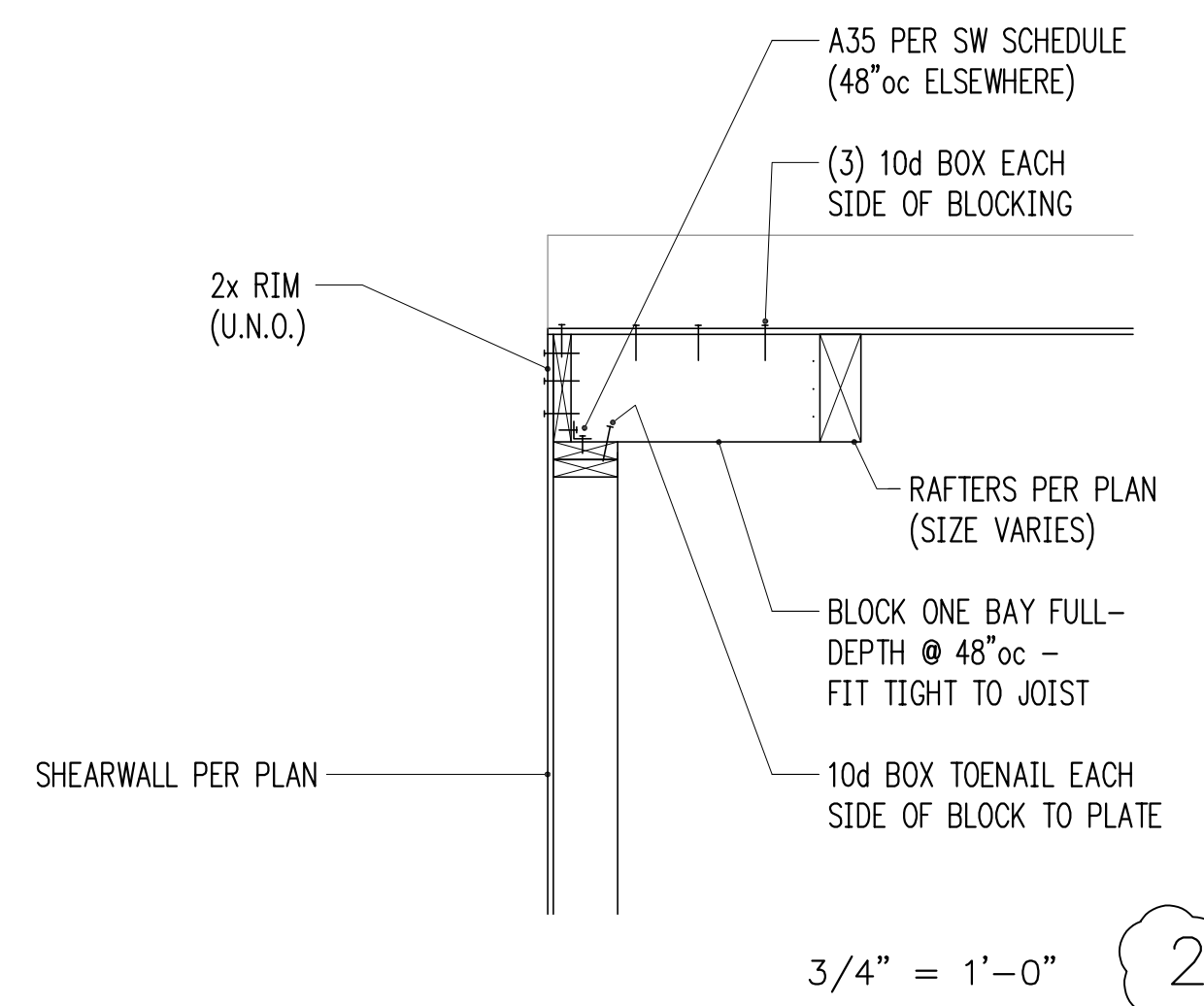
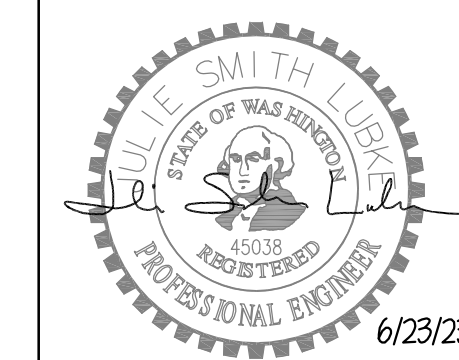

1 ROOF FRAMING PLAN (UPPER FLOOR WALLS)
scale: 1/4" = 1'-0"

FRAMING PLAN NOTES

- SW___ INDICATES SHEARWALL TYPE PER SCHEDULE 8/S3.2. REFER TO DETAILS FOR TYPICAL SHEARWALL CONSTRUCTION. SEE ARCHITECTURAL DRAWINGS FOR ADDITIONAL WALL INFORMATION.
- REFER TO GENERAL STRUCTURAL NOTES FOR FLOOR OR ROOF SHEATHING TYPE, THICKNESS, AND NAILING.
- COLUMNS SHALL BE DOUBLE STUD MINIMUM, UNLESS NOTED OTHERWISE. SEE 11/S3.2.
- AT ALL SHEARWALLS PROVIDE DOUBLE TOP PLATES AND SPLICE PER 12/S3.2.

HANGER SCHEDULE

MEMBER (FLAT ONLY)	HANGER	FACE NAILING	MEMBER FASTENERS	WEB STIFF REQUIRED
2x8	LU28	8-10d x 1 1/2	6-10d x 1 1/2	-
LVL 1 3/4x9 1/2	HUS1.81/10	30-10d x 1 1/2	10-10d	-
LVL 1 3/4x11 7/8	HUS1.81/10	30-10d x 1 1/2	10-10d	-
LVL 1 3/4x14	HUS1.81/10	30-10d x 1 1/2	10-10d	-
(2)LVL 1 3/4x14	U414	16-0.162 x 3 1/2	6-0.148 x 3	YES
9 1/2" TJI 110	IUS1.81/9.5	8-10dx1.5	2-STRONG GRIP	-
11 7/8" TJI 210	IUS2.06/11.88	10-10dx1.5	2-STRONG GRIP	-
14" TJI 110	IUS1.81/14	12-10dx1.5	2-STRONG GRIP	-
14" TJI 360	IUS2.37/14	12-10dx1.5	2-STRONG GRIP	-
14" TJI 560	MIU3.56/14	22-10dx1.5	2-10dx1.5	YES
4x16	CJT5Z	10-1/4"x3" SDS	(5) 1/2" x 2 3/4" LONG JOIST PINS	-

MEMBER (SLOPED ONLY)	HANGER	FACE NAILING	MEMBER FASTENERS	WEB STIFF REQUIRED
2x12	U210	10-0.162 x 3 1/2	6-0.148 x 1 1/2	-
3x10	U310	14-0.162 x 3 1/2	6-0.148 x 1 1/2	-

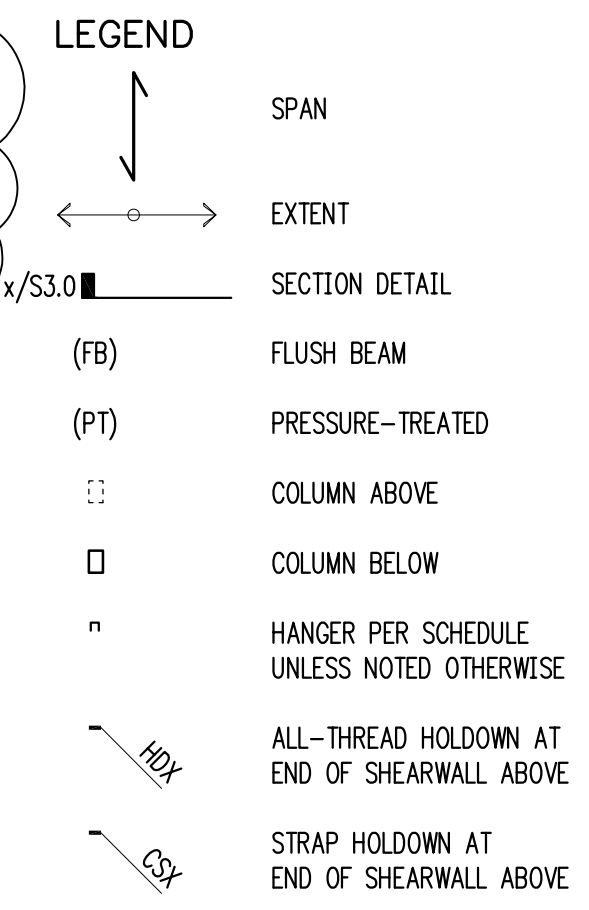

Sam + June
Mercer Island
3064 - 68th Avenue SE
Mercer Island, WA

Issue Date	Issue Description
1/17/23	Permit
6/24/23	Building Revisions

S2.4
ROOF FRAMING PLAN

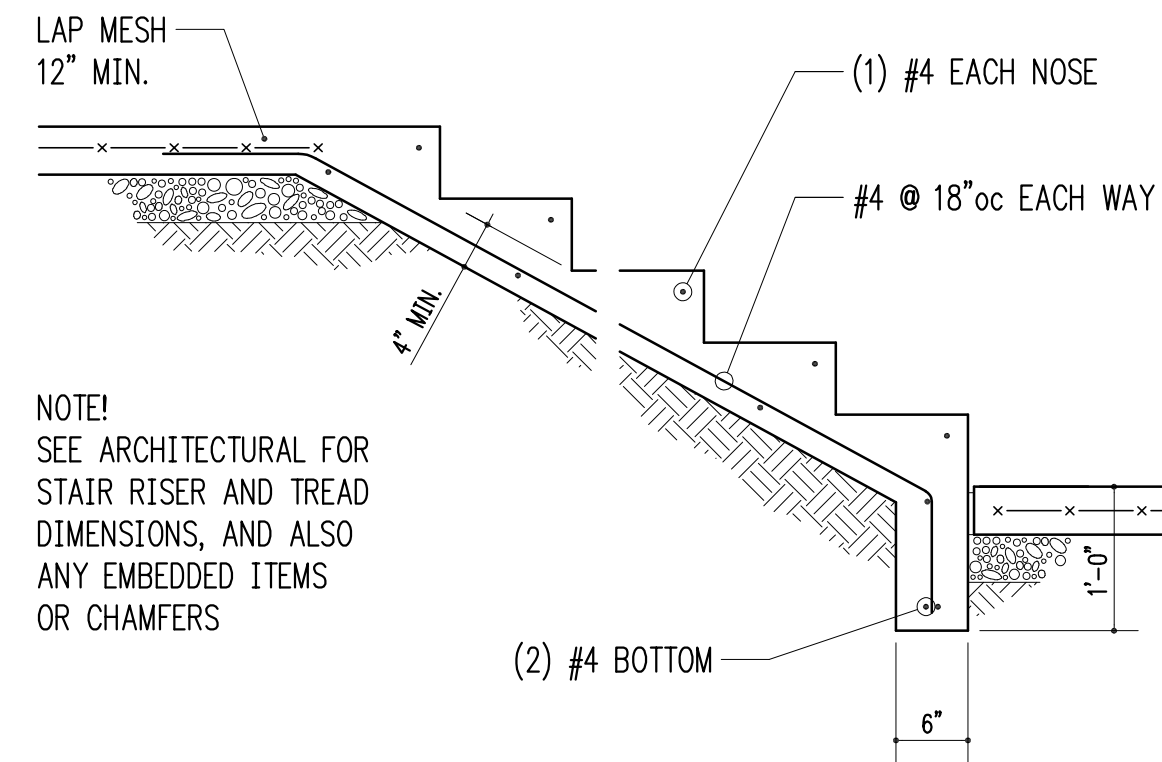

NOTE!
SEE ARCHITECTURAL FOR
STAIR RISER AND TREAD
DIMENSIONS, AND ALSO
ANY EMBEDDED ITEMS
OR CHAMFERS

TYPICAL STAIR-ON-GRADE
3/4" = 1'-0" 1

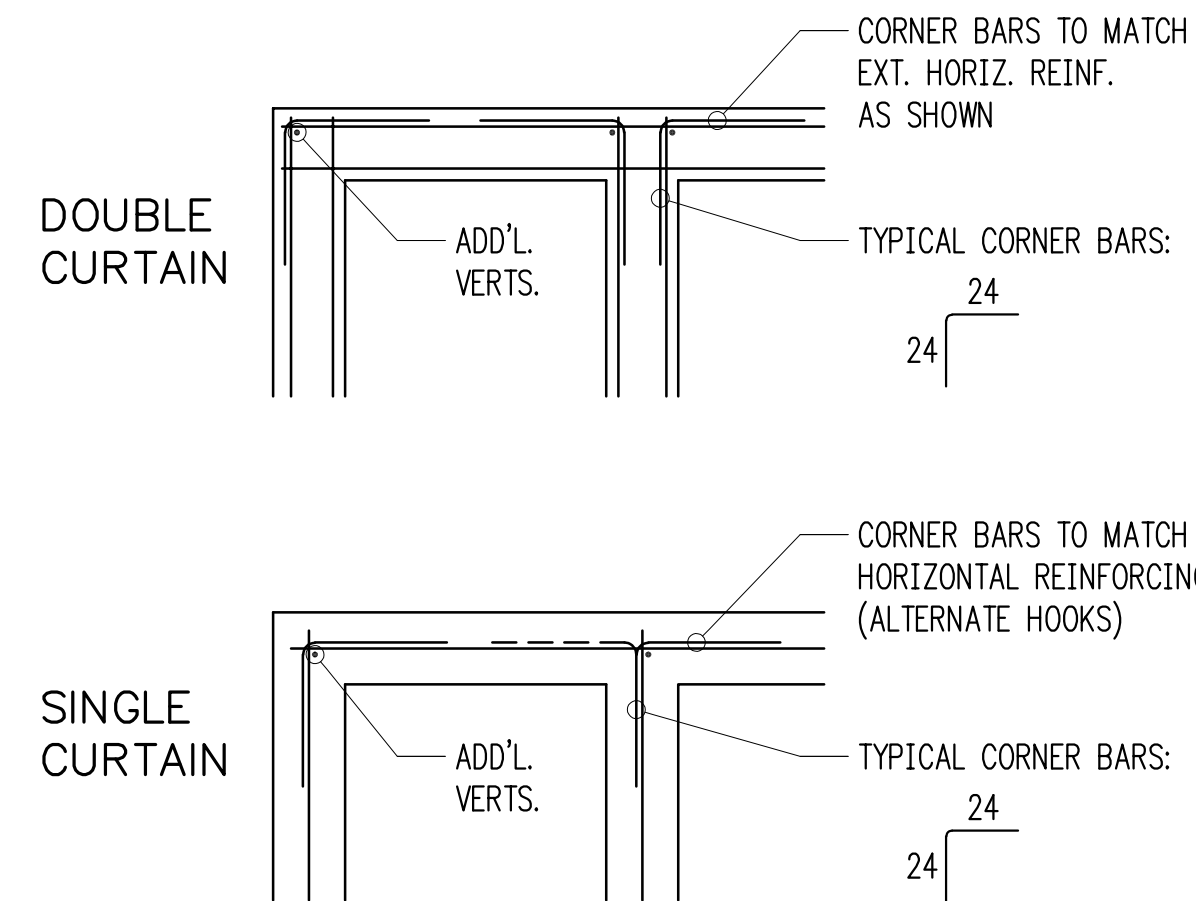

TYPICAL CORNER BARS AT CONCRETE WALLS
3/4" = 1'-0" 2

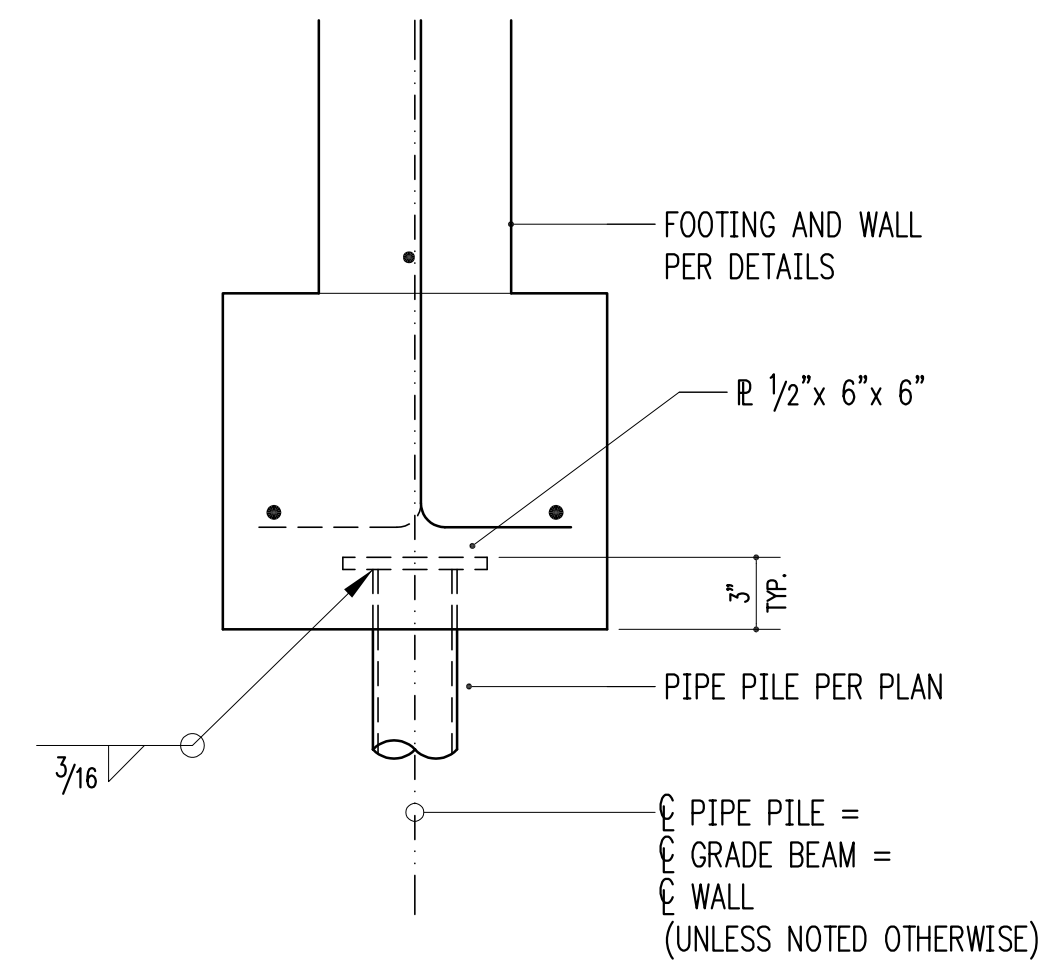

TYPICAL PIPE PILE EMBEDMENT
1-1/2" = 1'-0" 3

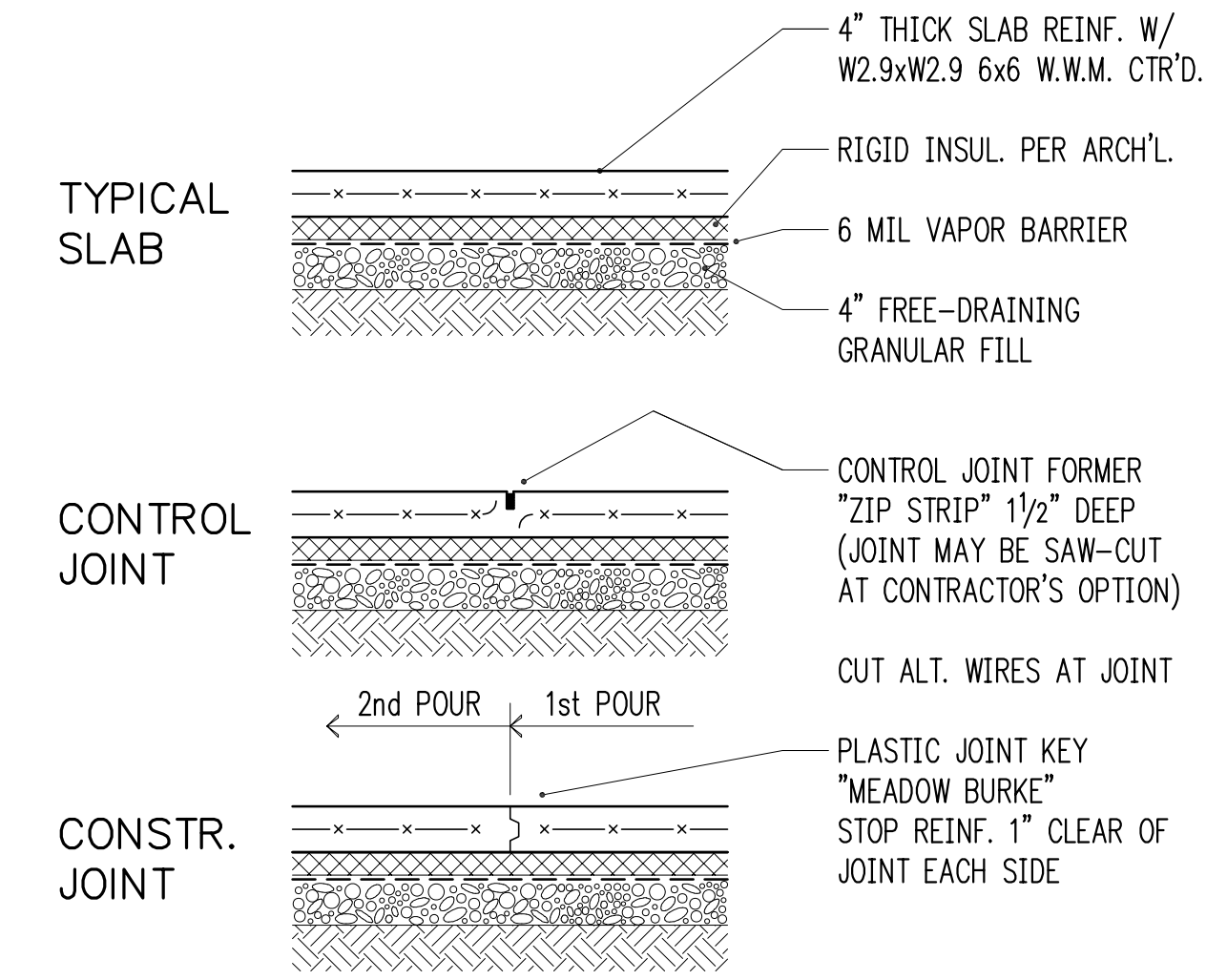

SLAB-ON-GRADE (INSULATED)
3/4" = 1'-0" 4

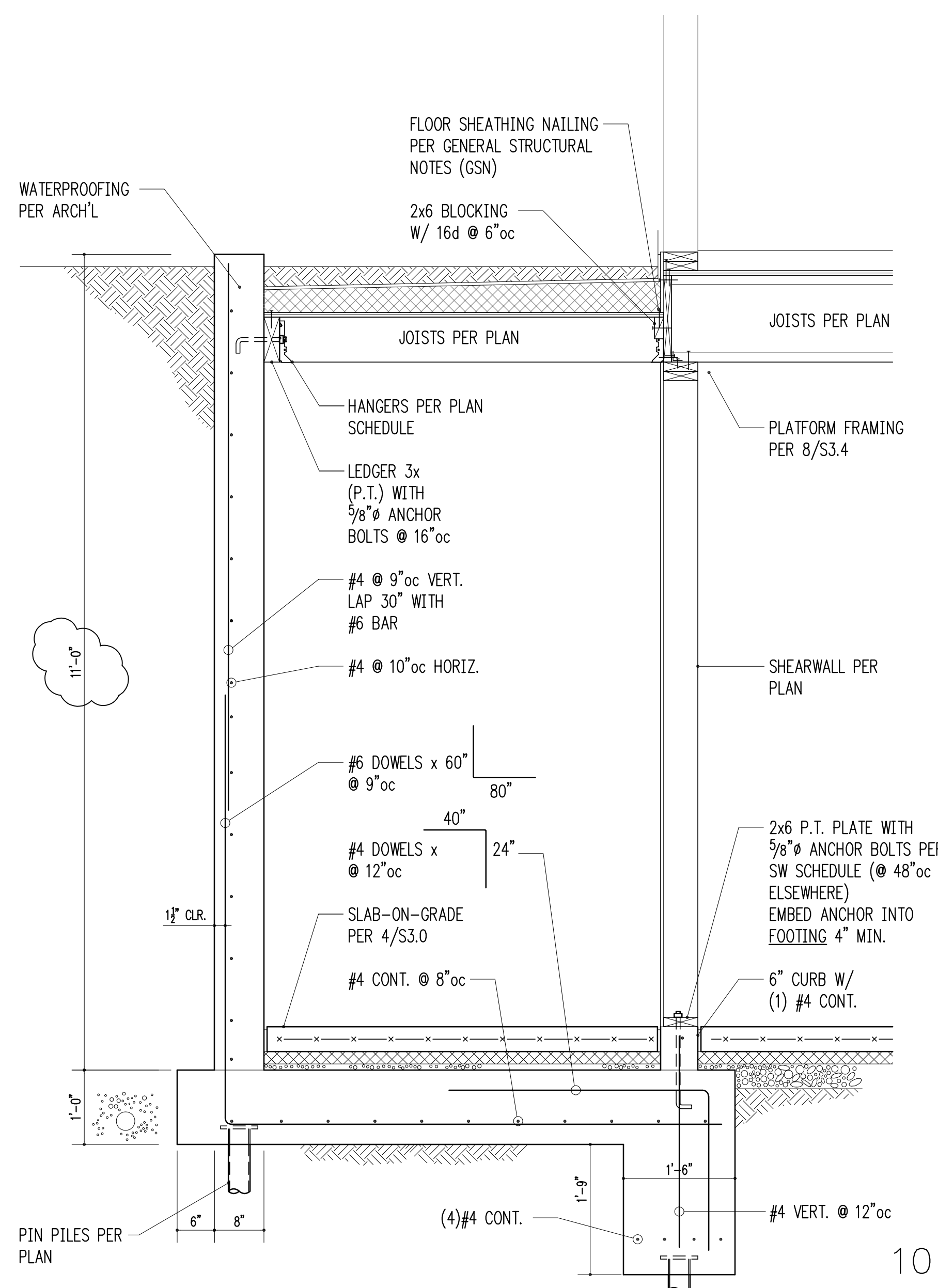

10

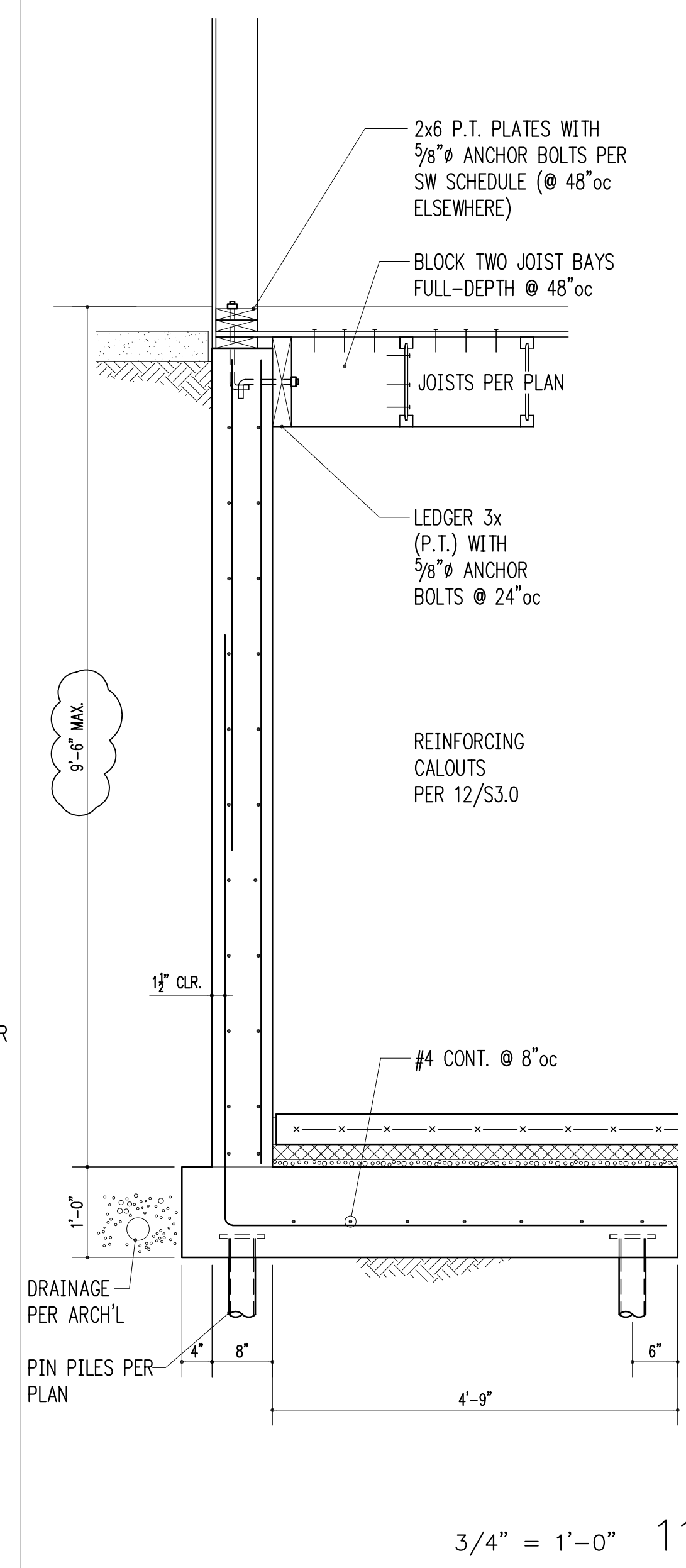

3/4" = 1'-0" 11

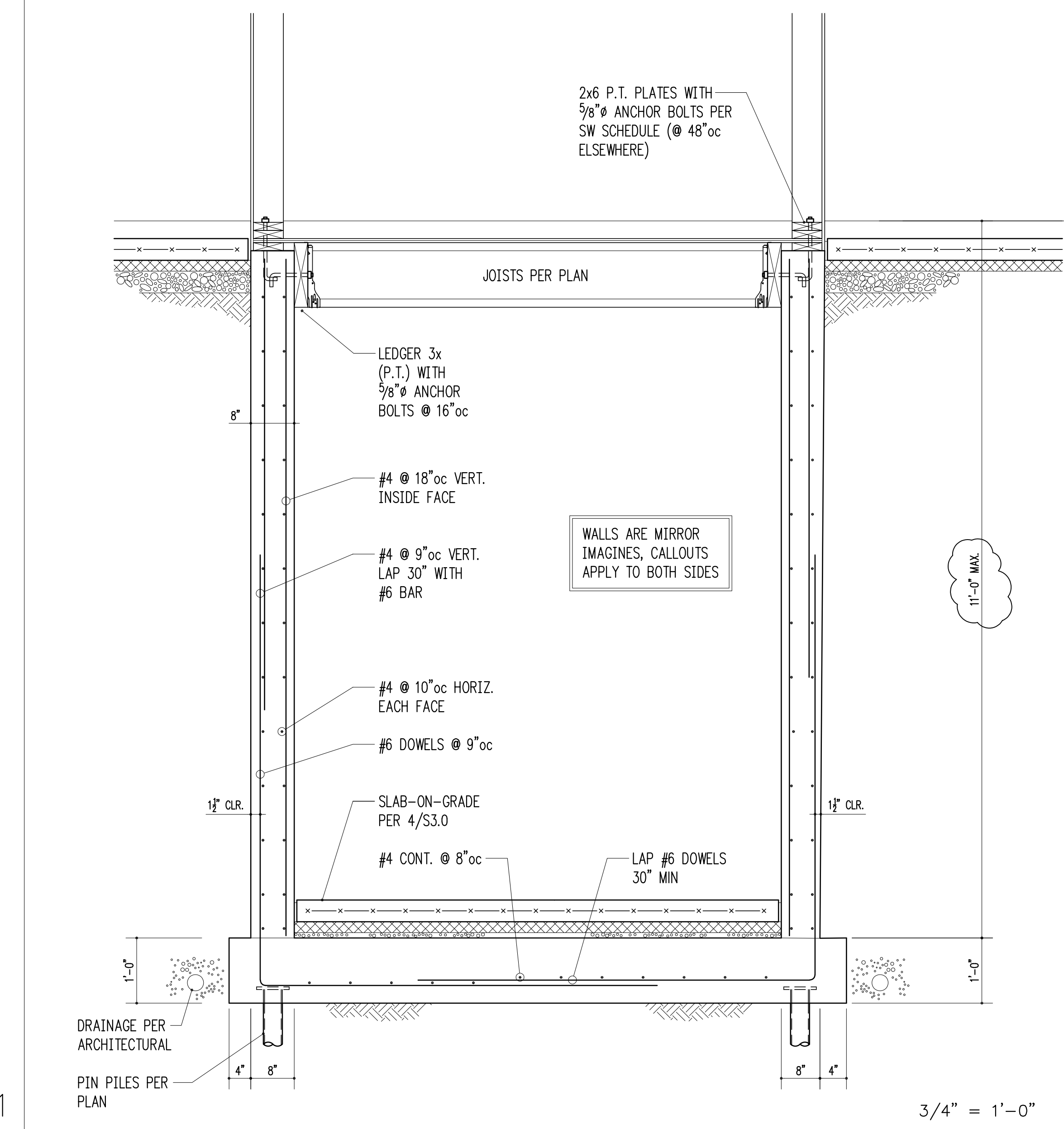

3/4" = 1'-0" 12

Issue Date	Issue Description
1/17/23	Permit
6/24/23	Building Revisions

SHEAR TAB SCHEDULE

BEAM SIZE	# BOLTS	BOLT SIZE	R THICK.	WELD SIZE	CAPACITY
W8, W10	(2)	3/4"Ø	1/4"	3/16"	8,200 lb

BOLT TYPE SHALL BE A325N. PLATE MATERIAL SHALL BE A36.

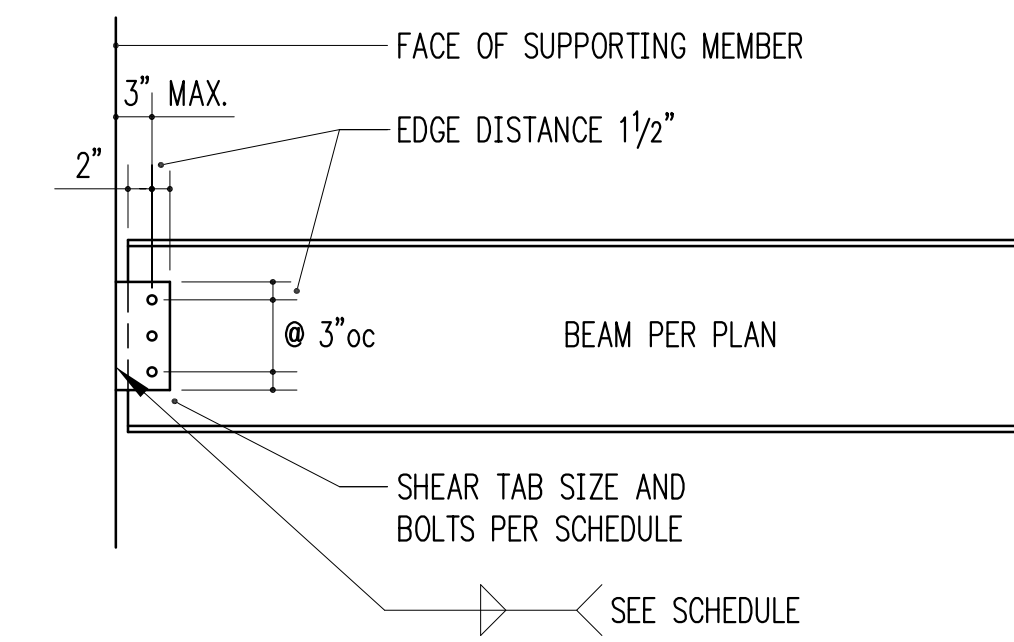

TYPICAL SHEAR TAB CONNECTION

3/4" = 1'-0" 1

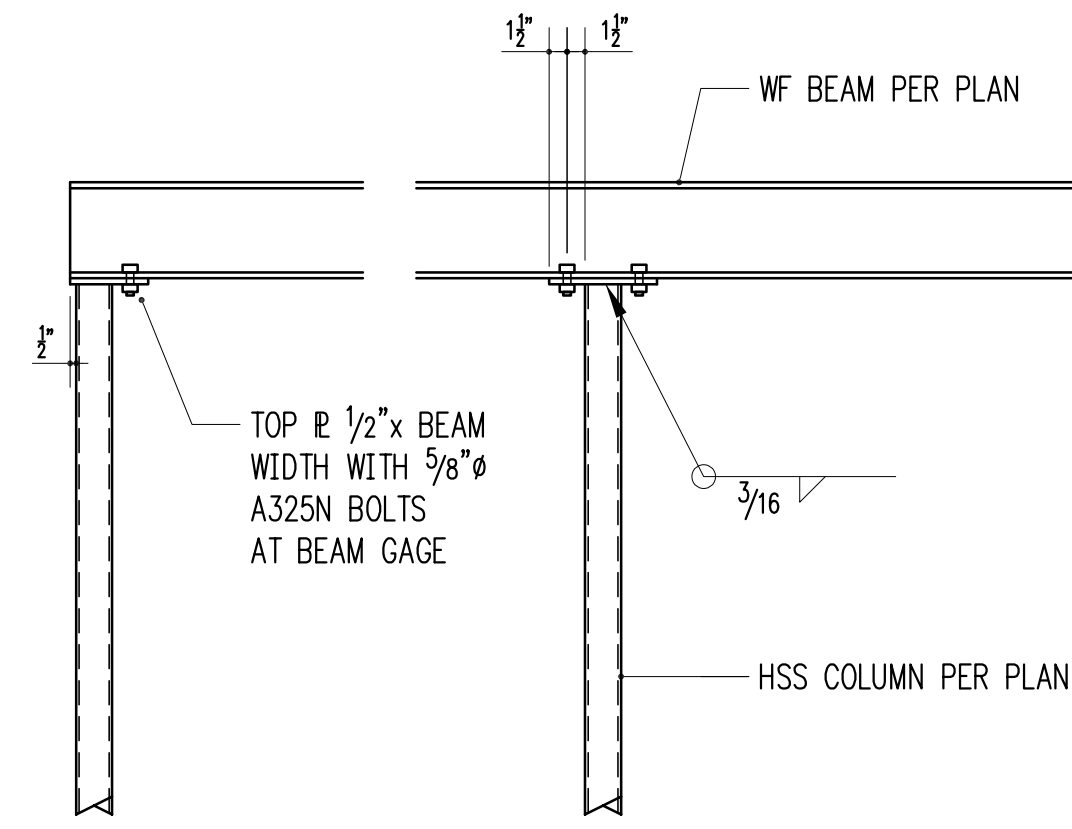

WF BEAM BEARING ON HSS COLUMN

3/4" = 1'-0" 2

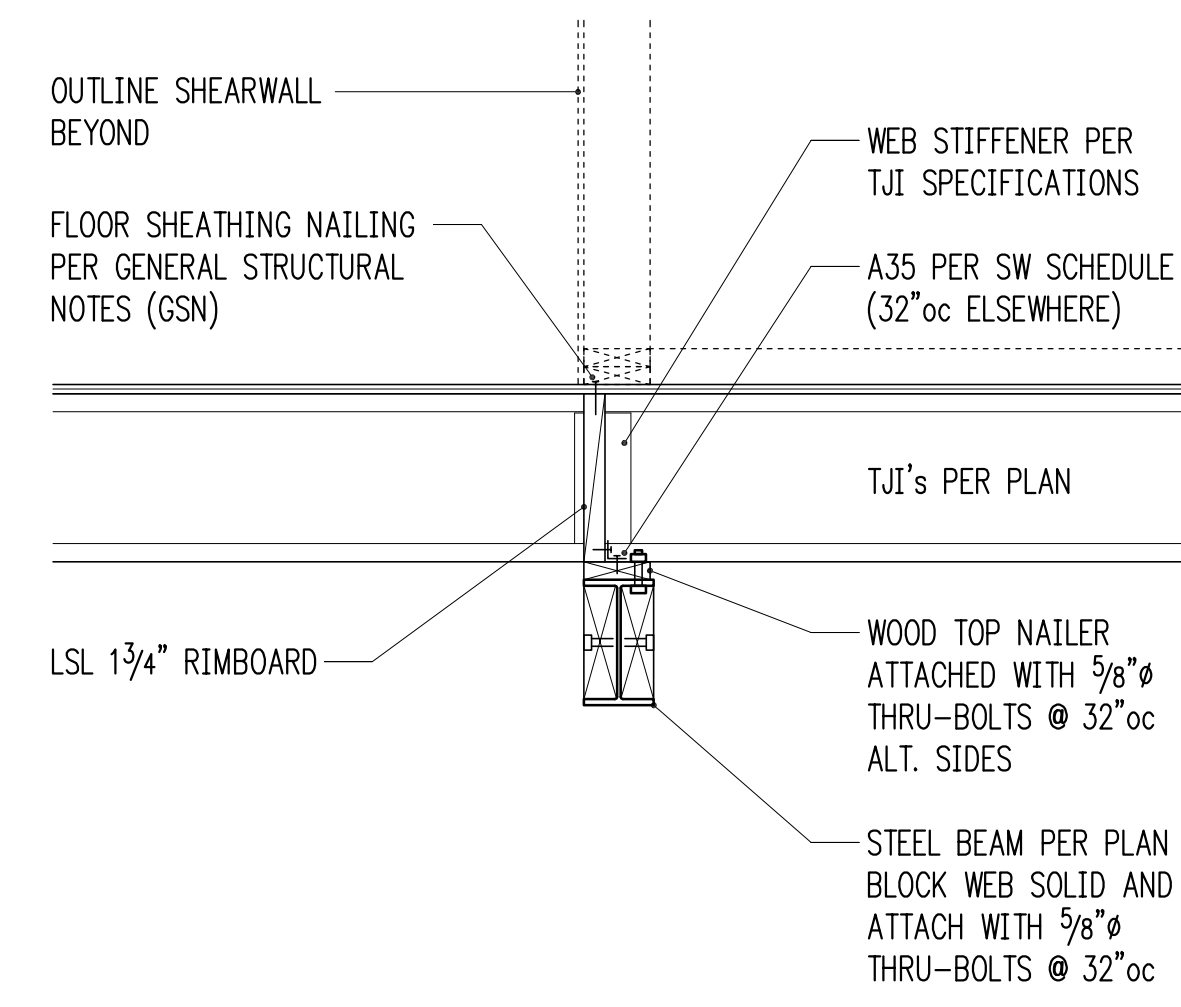

3/4" = 1'-0" 3

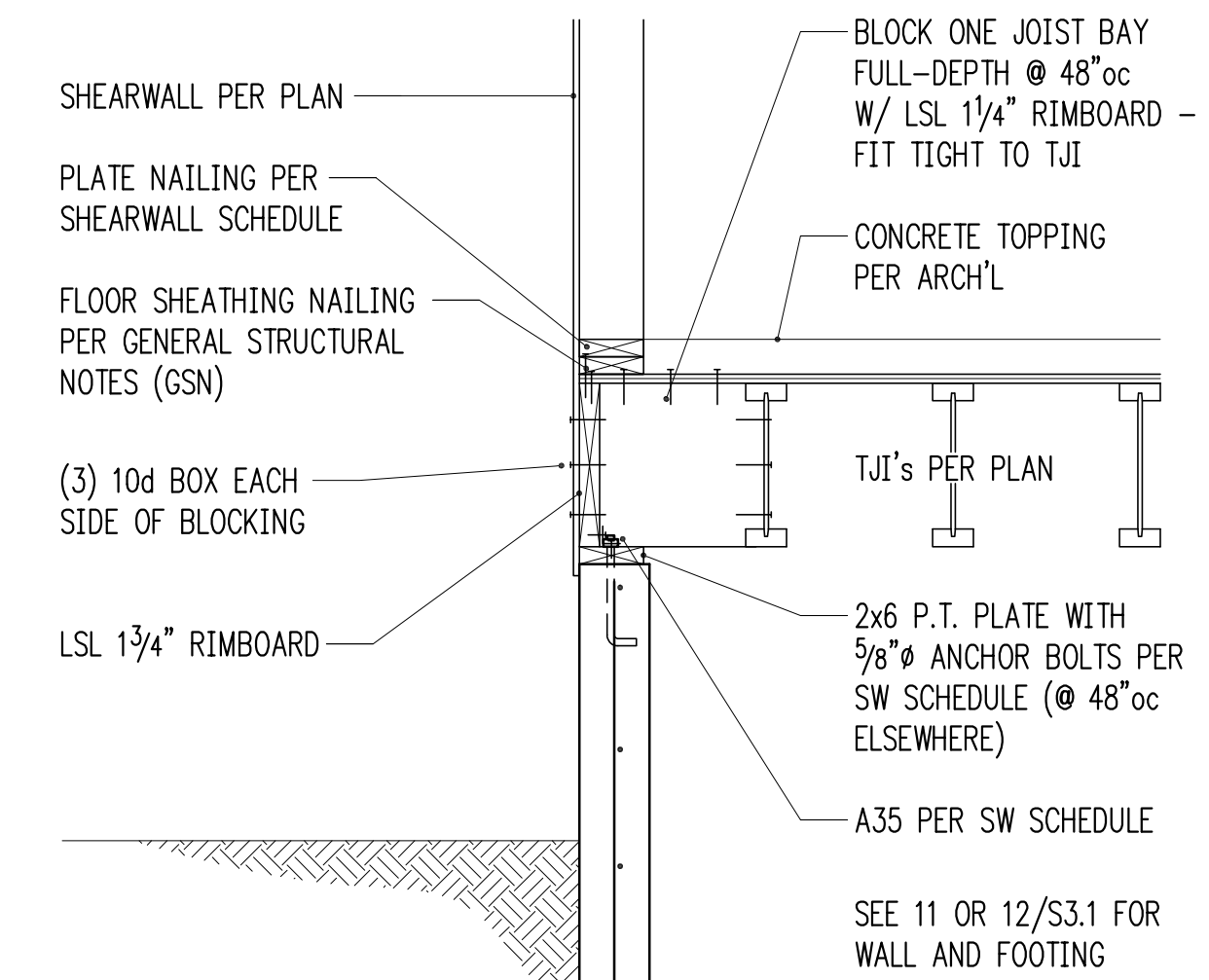

3/4" = 1'-0" 4

NAILER TYPE:

STUD WALL OR SHEARWALL FIELD NAILER

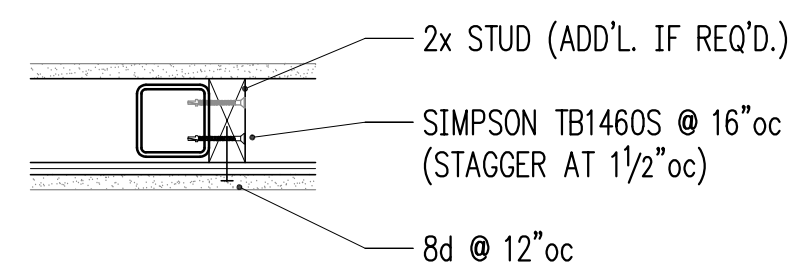

SHEARWALL BOUNDARY NAILER

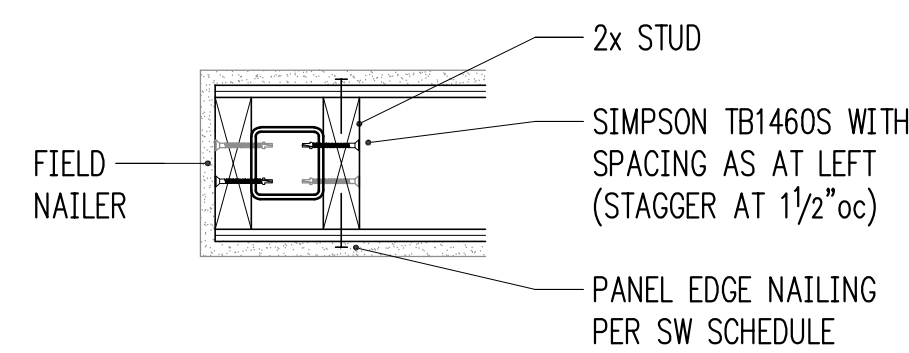

- SW1 16"oc
- SW2 12"oc
- SW3 9"oc
- SW4 7"oc
- SW5 4 1/2"oc
- SW6 3 1/2"oc

HSS COLUMN NAILERS

1-1/2" = 1'-0" 5

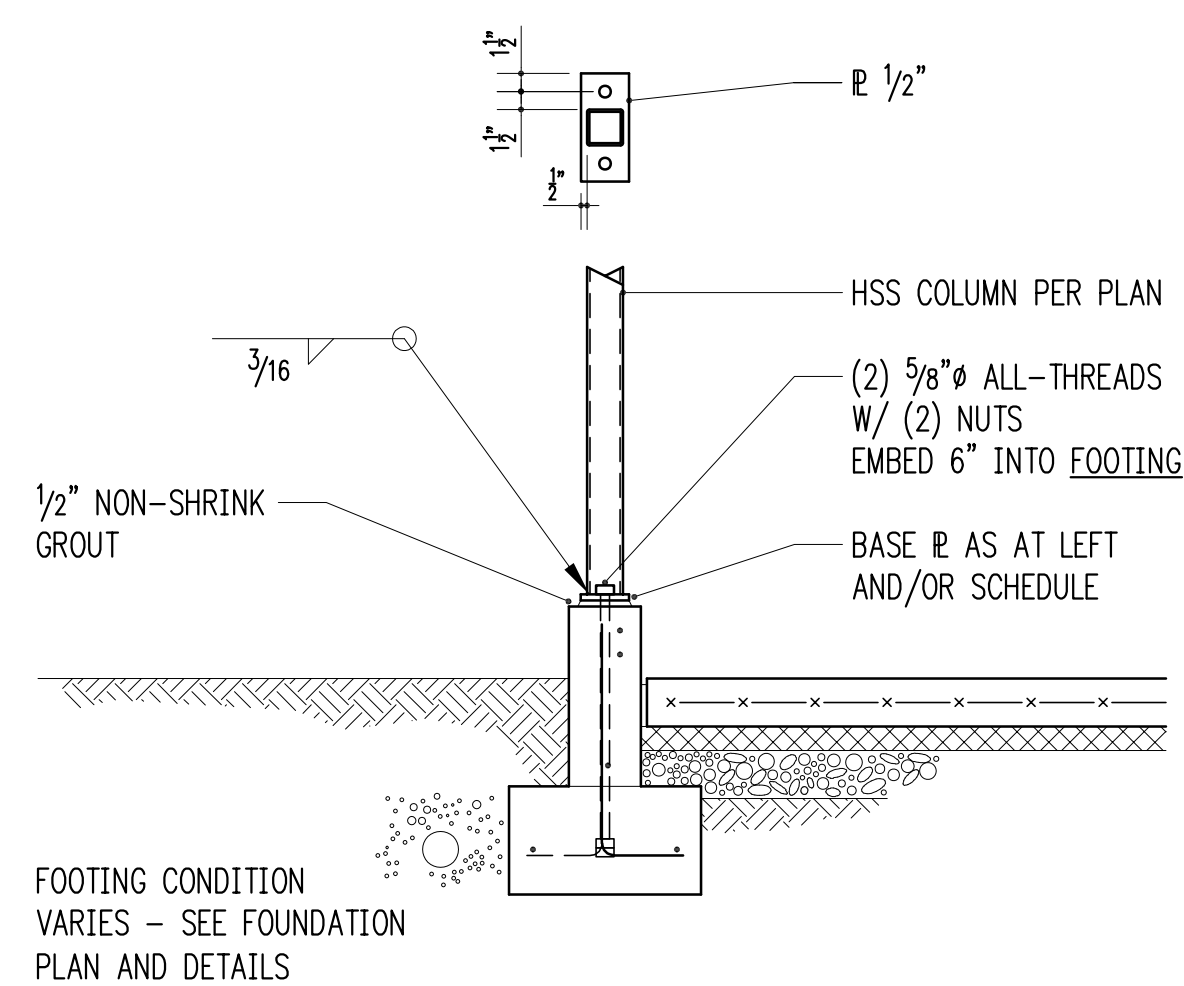

HSS COLUMN BASE PLATES

3/4" = 1'-0" 6

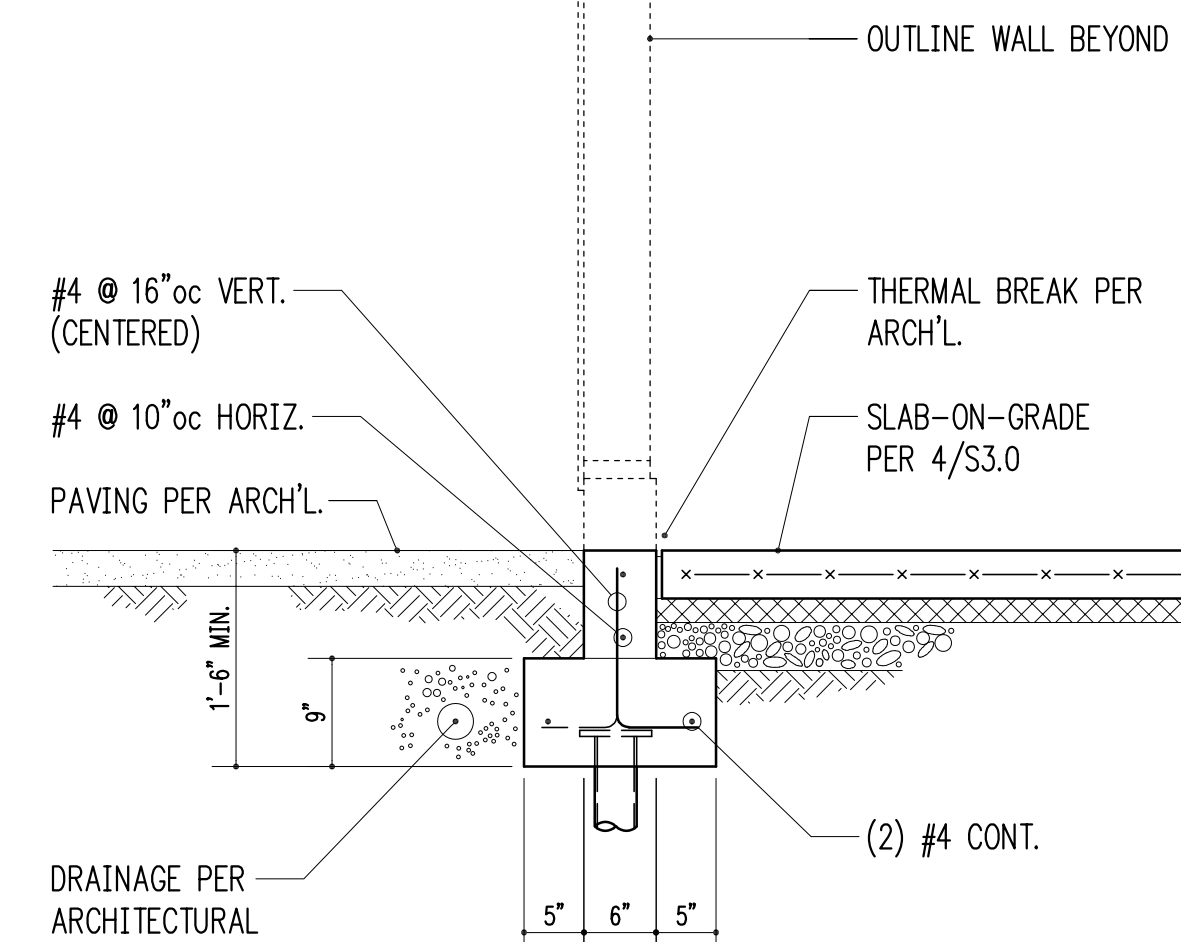

3/4" = 1'-0" 7

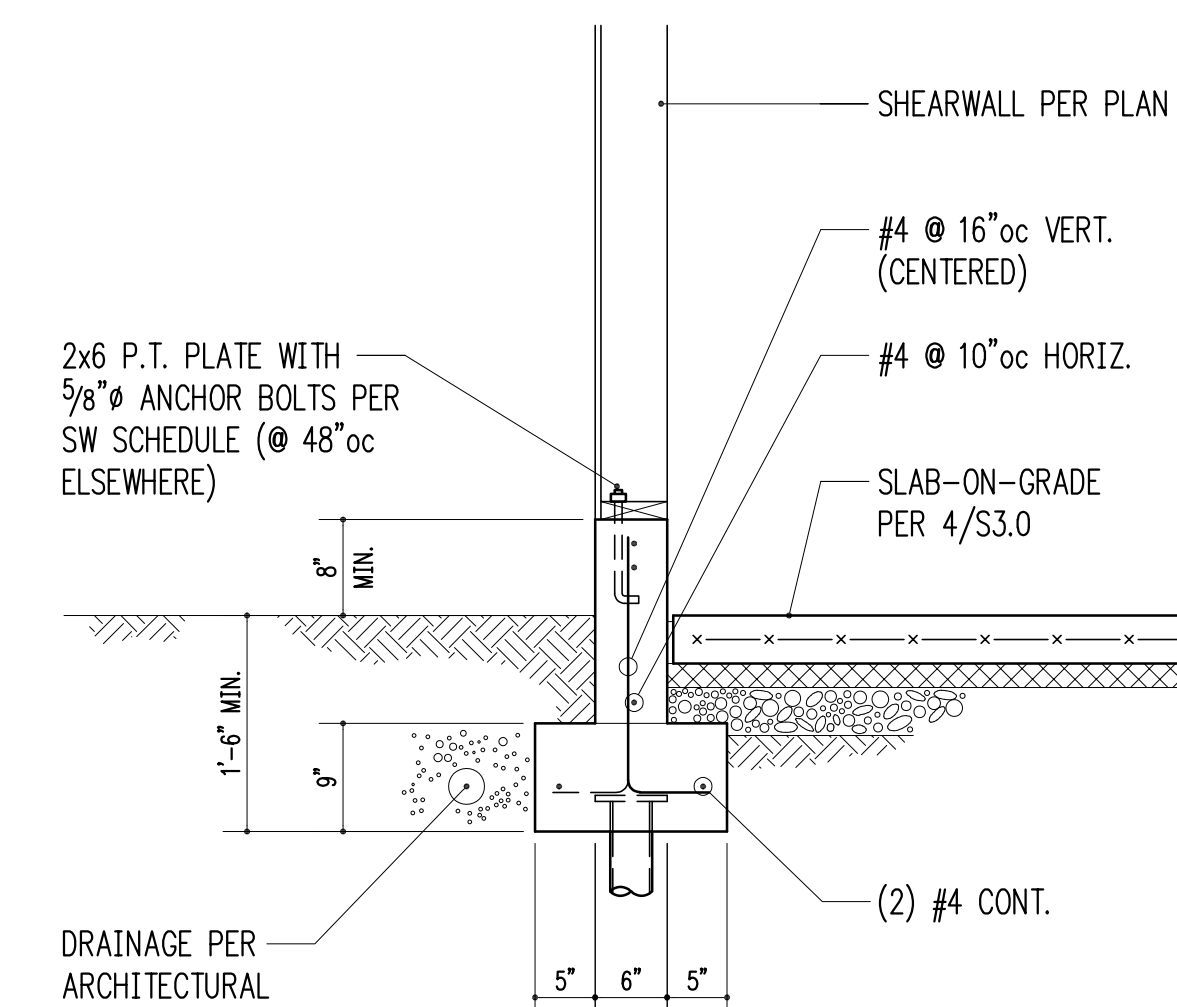

3/4" = 1'-0" 8

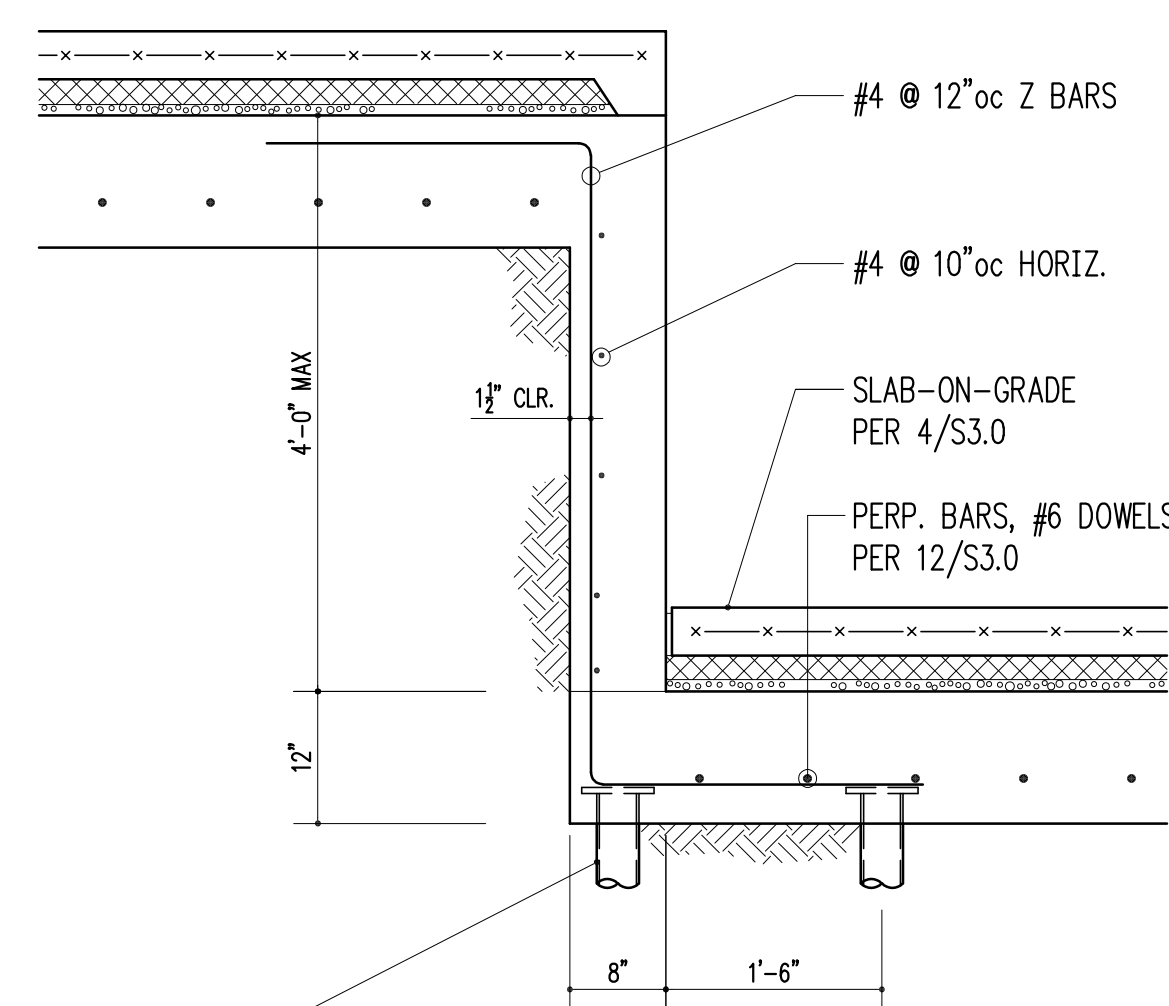

3/4" = 1'-0" 9

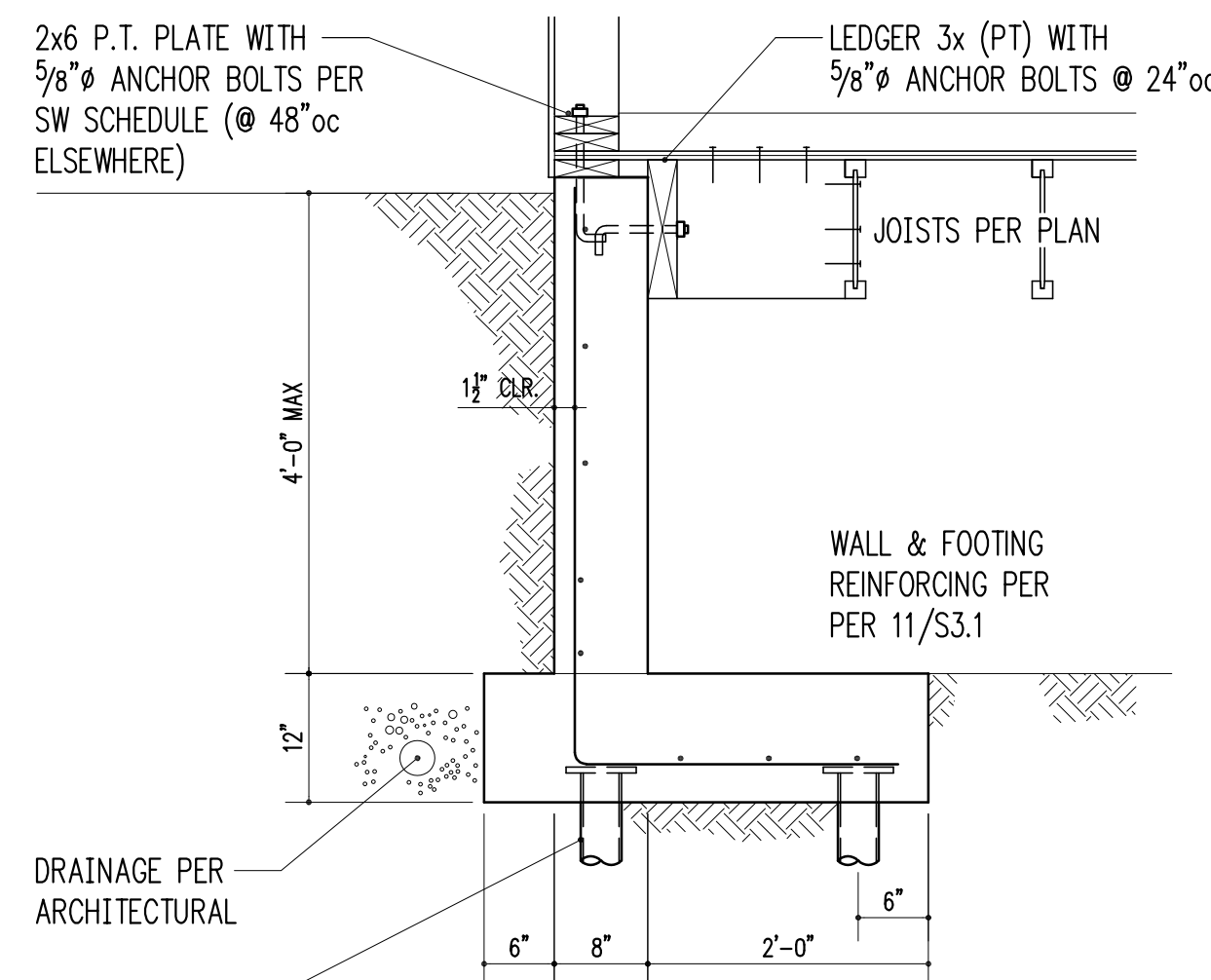

3/4" = 1'-0" 10

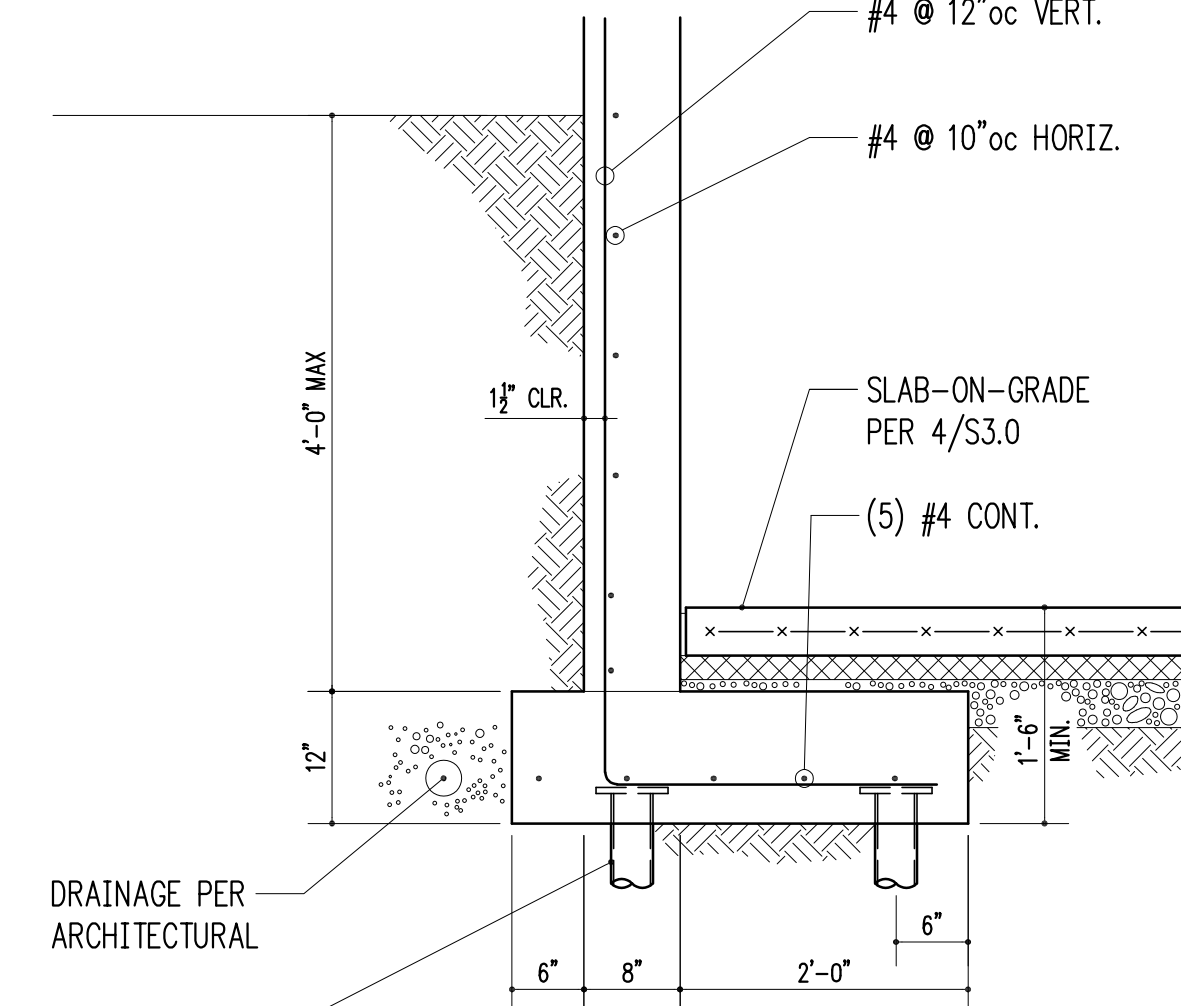

3/4" = 1'-0" 11

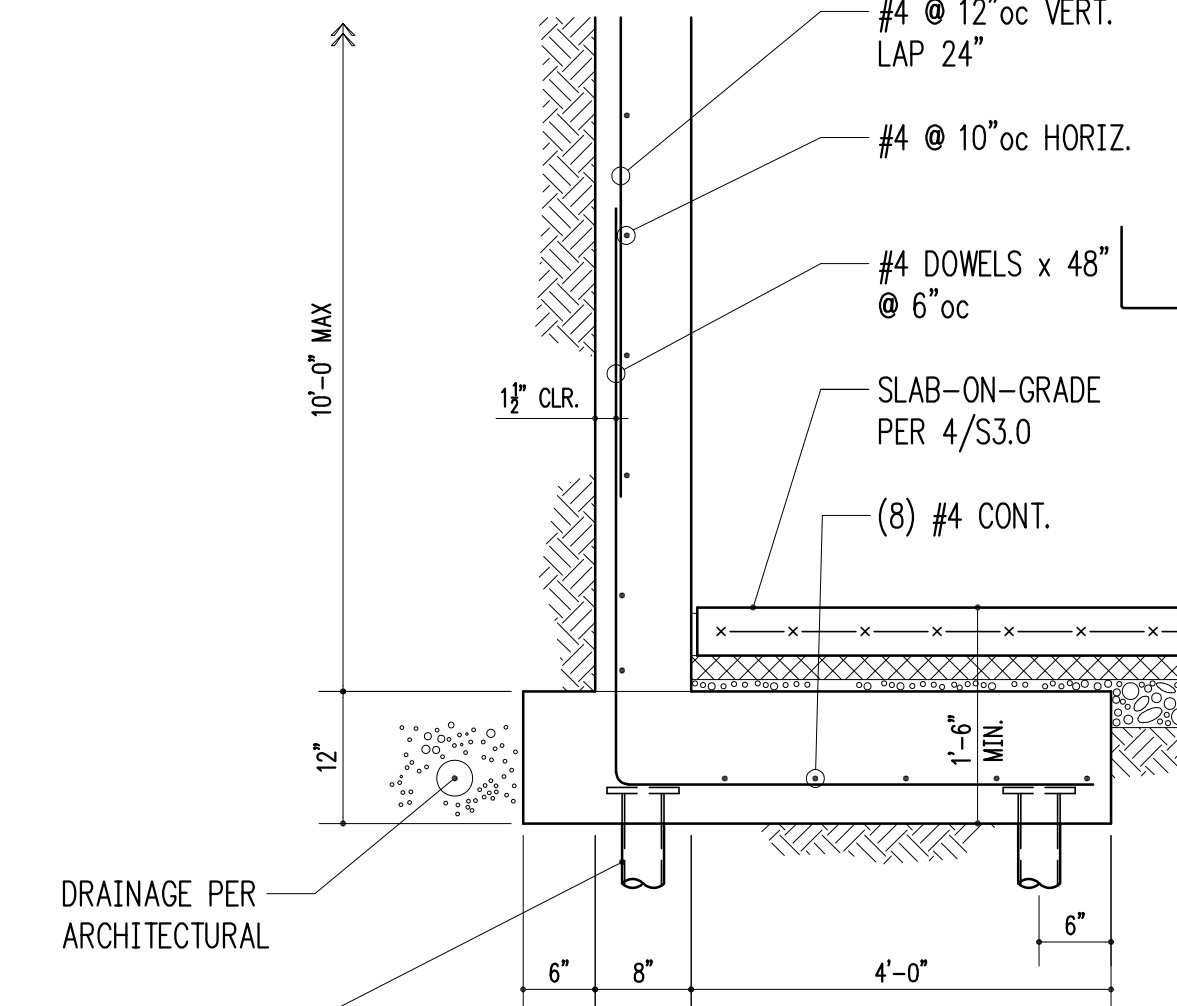

3/4" = 1'-0" 12

Issue Date	Issue Description
1/17/23	Permit
6/24/23	Building Revisions

STRAP SCHEDULE

MARK	END LENGTH	NAILS	NAIL SPACING
CMST12	44"	(98) 10d x 3"	1 3/4"
CMST14	34"	(76) 10d x 3"	1 3/4"
CMSTC16	25"	(58) 12d x 3 1/4"	1 1/2"
CS14	19"	(36) 8d x 2 1/2"	2 1/16"
CS16	14"	(26) 8d x 2 1/2"	2 1/16"
CS20	9"	(16) 8d x 2 1/2"	2 1/16"
CSHP20	8"	(12) 0.148" x 2 1/2"	1 3/16"

- 10d AND 12d DIAMETER = 0.148"; 8d DIAMETER = 0.131".
- USE HALF OF THE REQUIRED NAILS IN EACH MEMBER BEING CONNECTED (i.e. IN EACH END LENGTH).

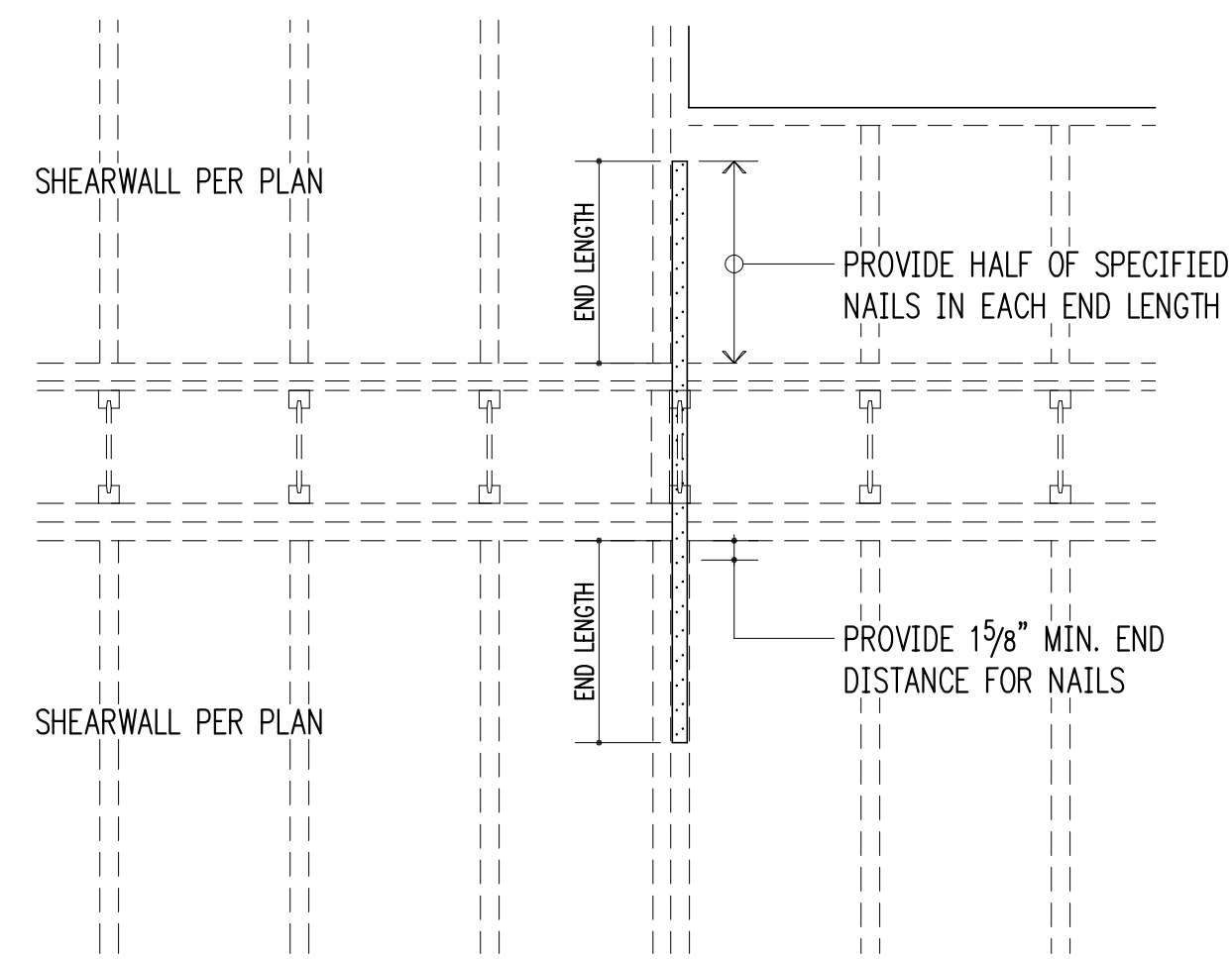

TYPICAL STRAP HOLDDOWN AT FLOOR

3/4" = 1'-0" 1

3/4" = 1'-0" 2

SHEARWALL SCHEDULE

MARK	SHEATHING ¹	STUDS AT ABUTTING PANEL EDGES ²	PANEL EDGE NAILING ^{3,4}	RIM JOIST OR BLOCKING TO TOP PLATE		BOTTOM PLATE ATTACHMENT		
				SOLID RIM	TJI RIM	BOTTOM PLATE TO RIM JOIST BELOW ⁴	ANCHOR BOLT TO CONCRETE ⁵	SILL PLATE AT FOUND.
SW1	15/32" CDX PLYWOOD	2x	8d @ 6"oc	A35 @ 24"oc	16d @ 6"oc	16d @ 6"oc	5/8" @ 48"oc	2x
SW2	15/32" CDX PLYWOOD	2x	8d @ 4"oc	A35 @ 15"oc	16d @ 4"oc	16d @ 4"oc	5/8" @ 32"oc	2x
SW3	15/32" CDX PLYWOOD	3x	8d @ 2"oc	A35 @ 9"oc	N/A - USE SOLID RIM	16d @ 2"oc	5/8" @ 12"oc	2x
SW4	15/32" CDX PLYWOOD BOTH SIDES	3x	8d @ 2"oc	A35 @ 4 1/2"oc	N/A - USE SOLID RIM	(2) ROWS 16d @ 2"oc	5/8" @ 12"oc	3x

- WALL SHEATHING SHALL CONSIST OF APA RATED PLYWOOD WITH SPAN RATING 24/0. ALLOW 1/8" SPACING AT ALL PANEL EDGES AND ENDS OF PANELS. 7/16" APA RATED SHEATHING (OSB) MAY BE USED IN PLACE OF 15/32" CDX.
- STUDS AT ABUTTING PANEL EDGES MAY CONSIST OF (2)2x STUDS IN PLACE OF 3x STUDS - NAIL (2)2x STUDS TOGETHER WITH BOTTOM PLATE ATTACHMENT NAILING.
- BLOCK ALL PANEL EDGES W/ 2x4 FLAT, ATTACH W/ PANEL EDGE NAILING. TWO STUDS MINIMUM ARE REQUIRED AT EACH END OF ALL SHEARWALLS. END STUDS SHALL RECEIVE PANEL EDGE NAILING. INTERMEDIATE STUDS SHALL BE 2x STUDS. NAIL SHEATHING TO INTERMEDIATE FRAMING MEMBERS WITH 8d @ 12"oc.
- 8d NAILS SHALL BE 0.131" DIAMETER x 2 1/2" (COMMON). 16d NAILS SHALL BE 0.135" DIAMETER x 3 1/2" (BOX).
- ANCHORS TO CONCRETE SHALL CONSIST OF CAST-IN-PLACE ANCHOR BOLTS, EXPANSION BOLTS, EPOXY GROUDED ALL-THREADS, OR TITEN HD HEAVY DUTY SCREW ANCHORS. CAST-IN-PLACE ANCHOR BOLTS HAVE A 7" EMBED AND SHALL BE J-BOLTS OR SHALL HAVE A HEX NUT AT THE BOTTOM END. EXPANSION BOLTS SHALL HAVE 5" EMBED AND SHALL NOT BE USED AT STEM WALL LOCATIONS WITH EDGE DISTANCE LESS THAN 5" (INSTEAD, USE EPOXY GROUDED ALL-THREADS OR TITEN HD ANCHORS). EPOXY GROUDED ANCHORS SHALL HAVE 5" EMBED AND 2 1/2" MIN. EDGE DISTANCE. TITEN HD ANCHORS SHALL HAVE 3 1/2" EMBED AND 1 3/4" MIN. EDGE DISTANCE. AT ALL ANCHOR BOLTS, PROVIDE STEEL PLATE WASHERS THAT ARE A MINIMUM OF 0.229" (3 GAUGE) x 3"x 3" (SIMPSON BP5/8-3 OR SIMILAR). STEEL PLATE WASHERS SHALL EXTEND TO WITHIN 1/2" OF PLYWOOD SHEATHING.

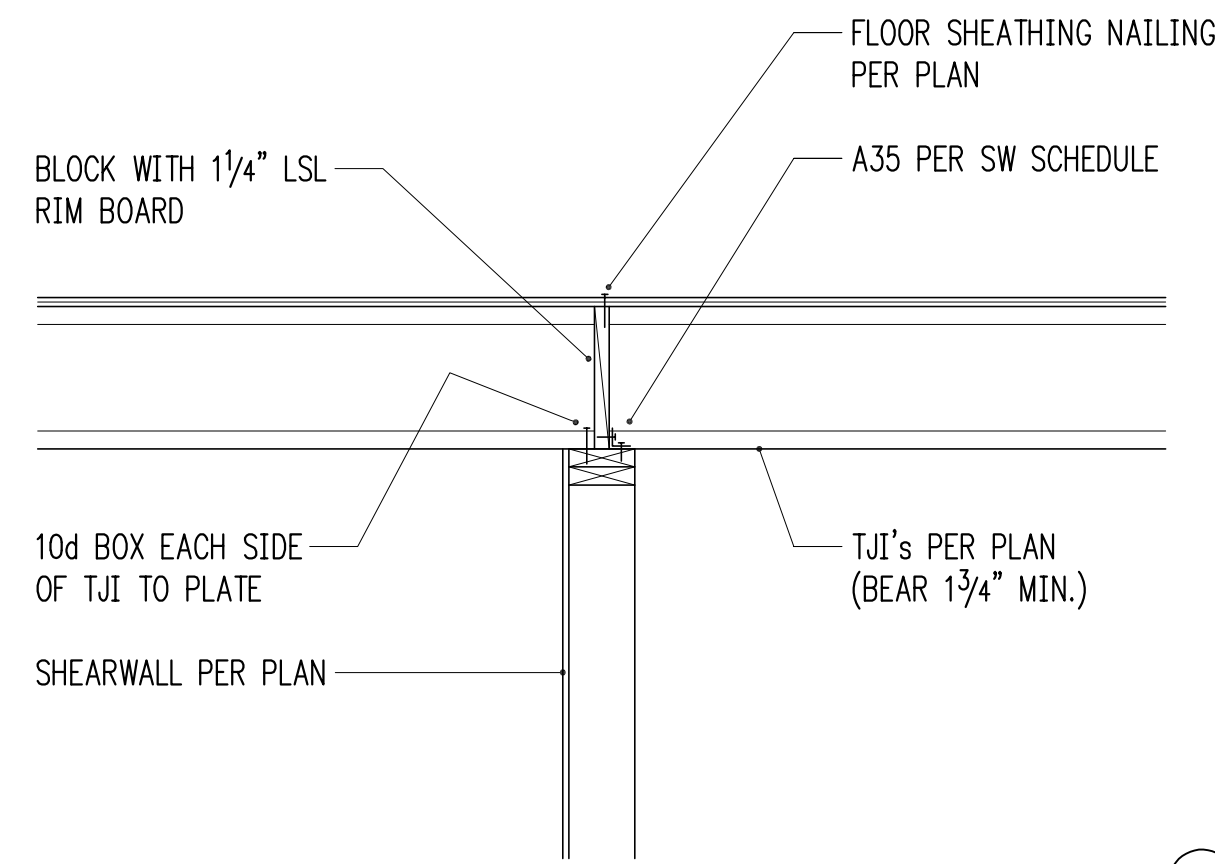

3/4" = 1'-0" 5

3/4" = 1'-0" 6

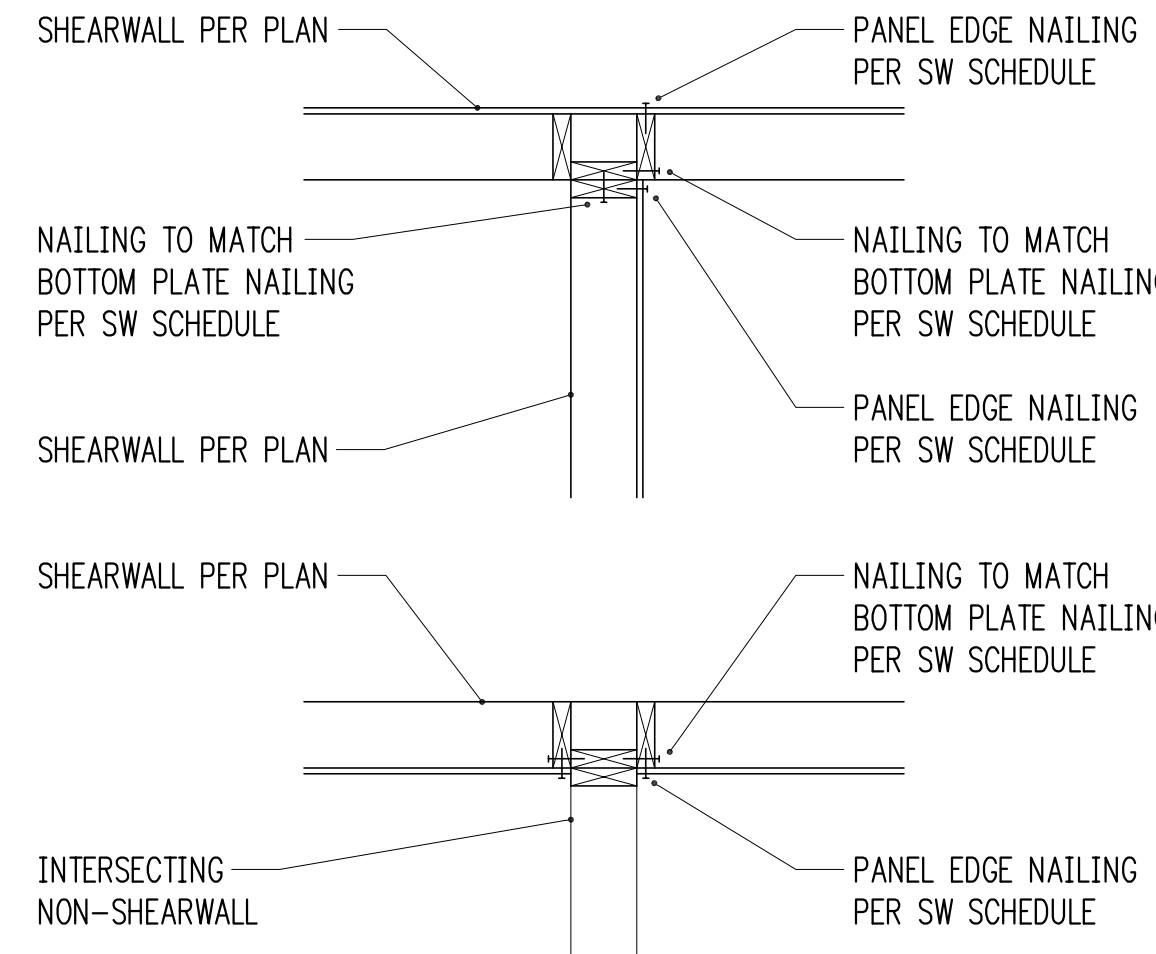

TYPICAL SHEARWALL INTERSECTIONS

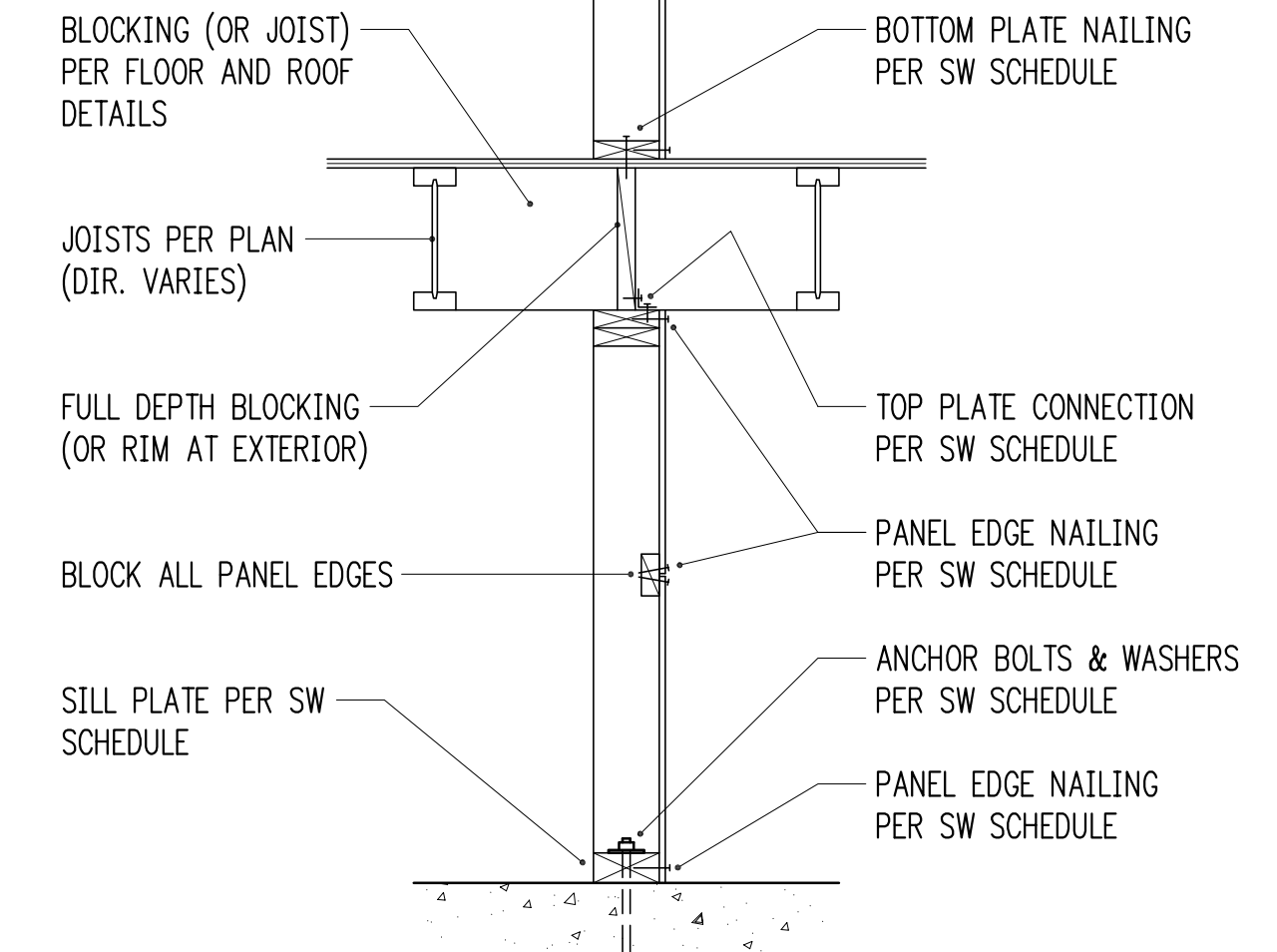

TYPICAL SHEARWALL SECTION

3/4" = 1'-0" 8

HOLDOWN SCHEDULE

MARK	FASTENERS TO STUDS ¹	ANCHOR DIA. ²	EMBEDMENT LENGTH	
			EPOXY ³	CAST-IN ⁴
DTT2Z	(8) 1/4" @ x 2 1/2" SCREWS	5/8"	7"	7"
HDU5	(14) 1/4" @ x 2 1/2" SCREWS	5/8"	-	37"

- 10d AND 12d DIAMETER = 0.148"; 16d DIAMETER = 0.162". SCREWS SHALL BE SIMPSON "SDS" TYPE SCREWS, INSTALL PER SIMPSON RECOMMENDATIONS.
- PROVIDE A36 OR A307 ALL-THREAD AT EPOXY AND CAST-IN ANCHORS.
- PROVIDE SIMPSON "SET-XP" EPOXY PER GENERAL STRUCTURAL NOTES. SPECIAL INSPECTION IS REQUIRED.
- AT CAST-IN ANCHORS PROVIDE HEAVY HEX NUT AT BOTTOM OF ALL-THREAD.

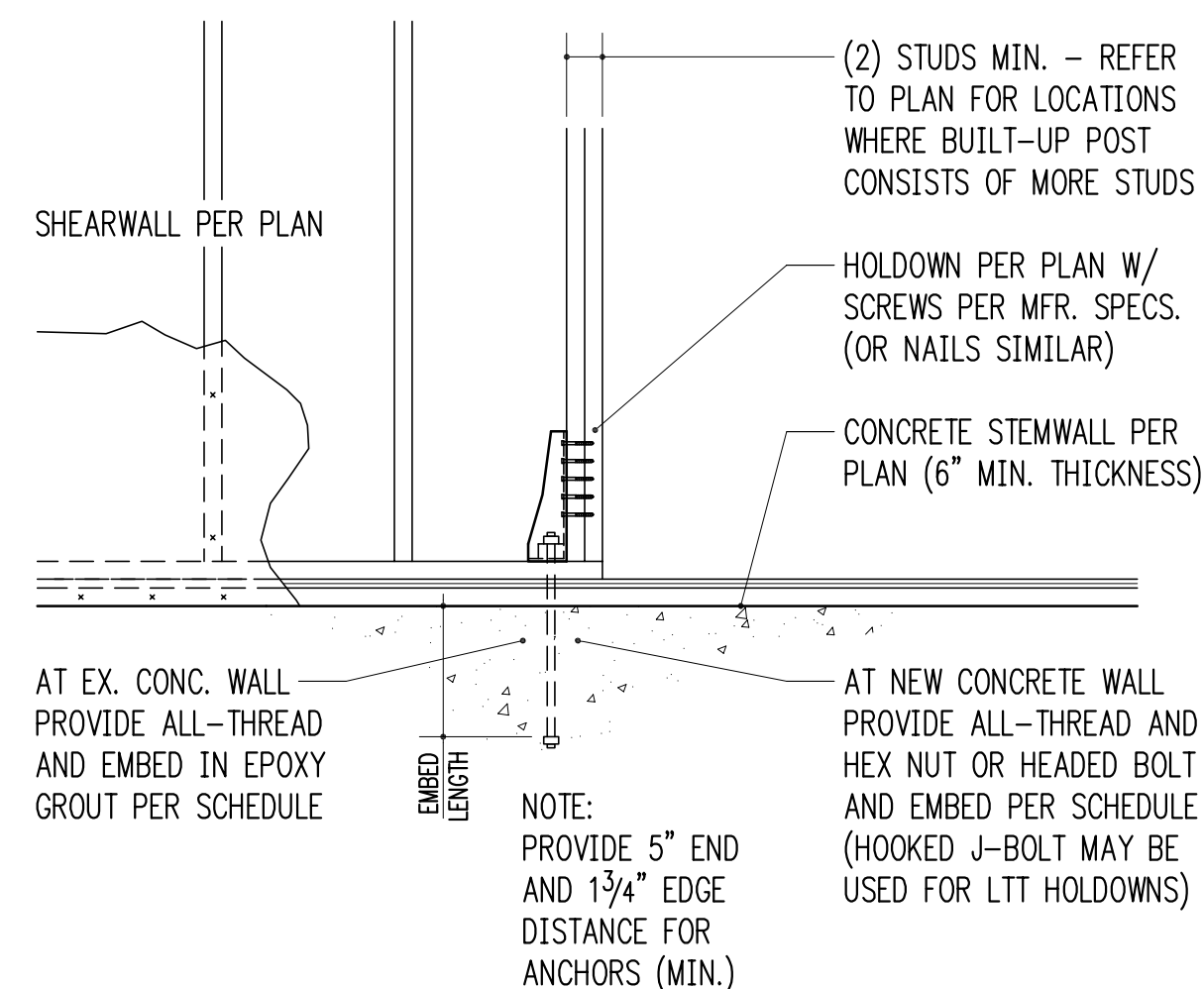

TYPICAL HOLDDOWN AT CONCRETE

3/4" = 1'-0" 10

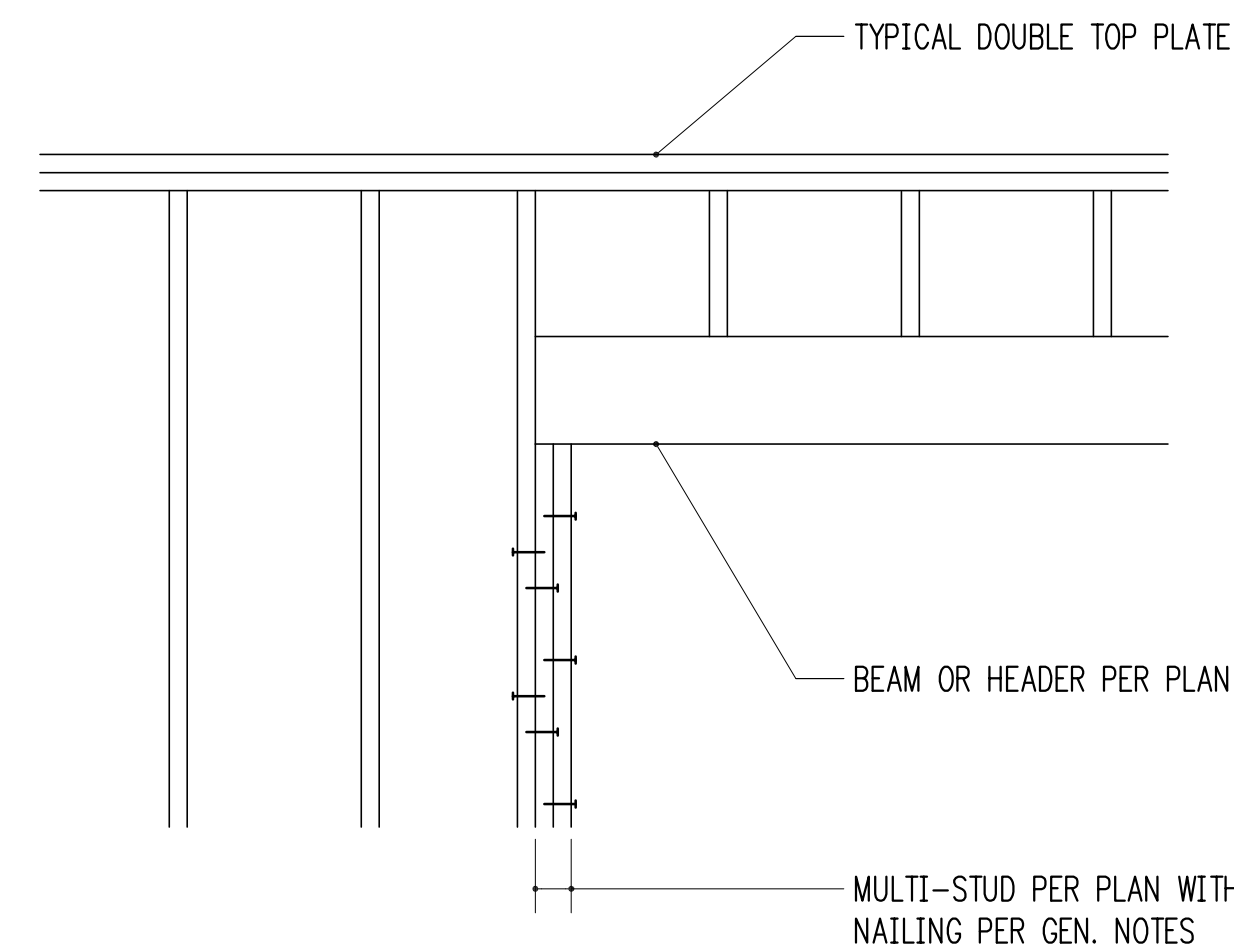

TYPICAL MULTIPLE-STUD POST CONSTRUCTION

3/4" = 1'-0" 11

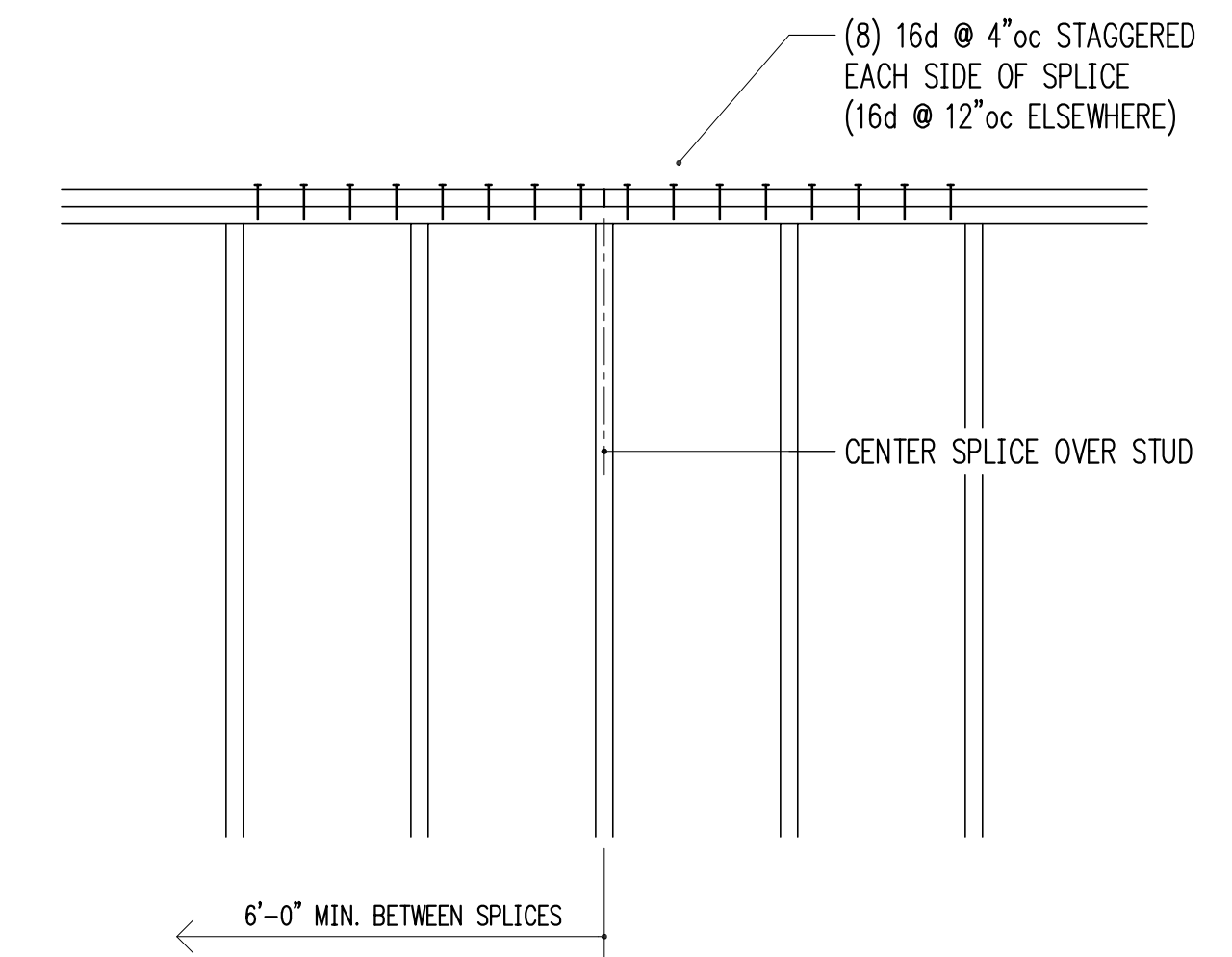

TYPICAL TOP PLATE SPLICE CONSTRUCTION

3/4" = 1'-0" 12

Issue Date	Issue Description
1/17/23	Permit
6/24/23	Building Revisions

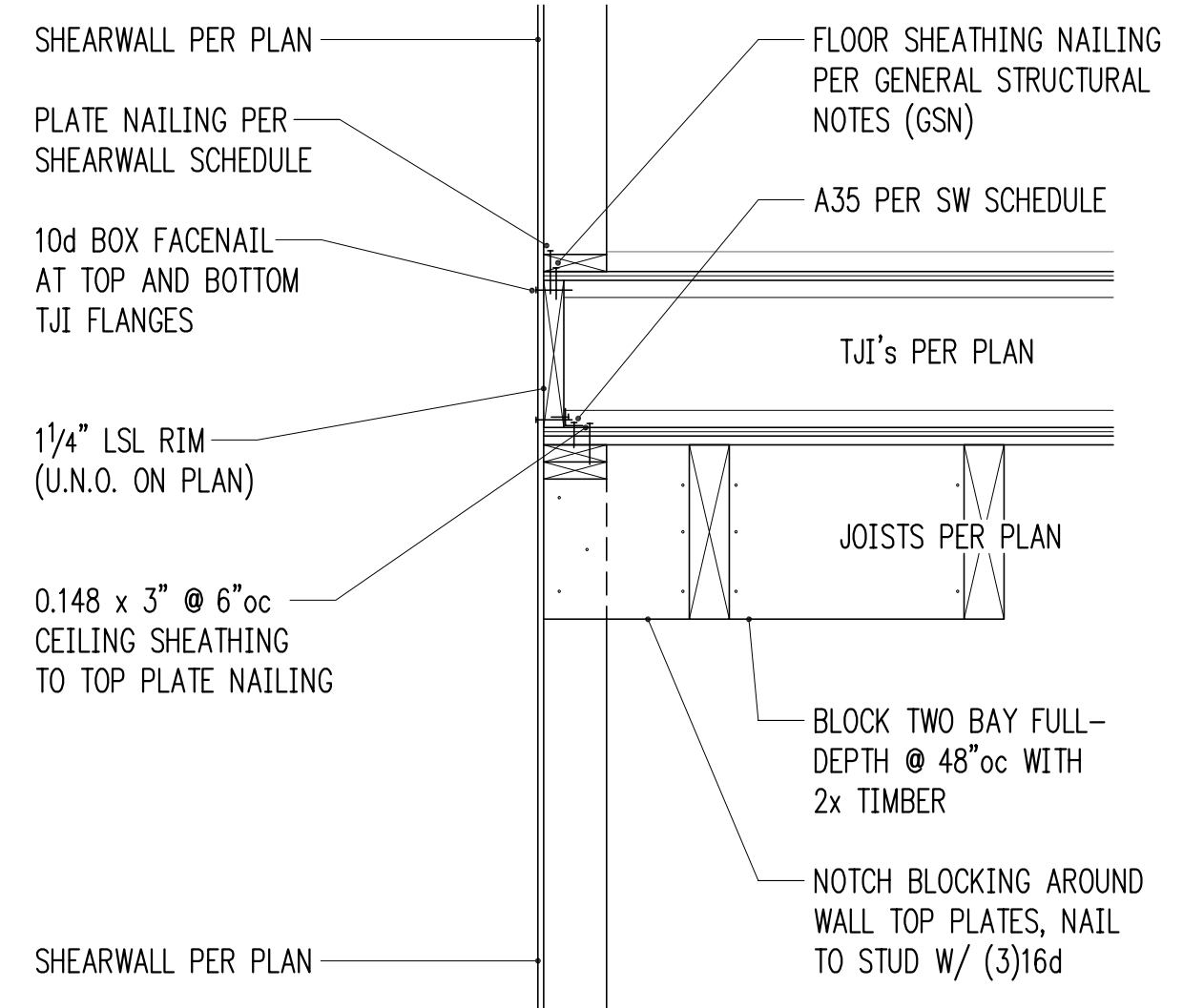

3/4" = 1'-0" 1

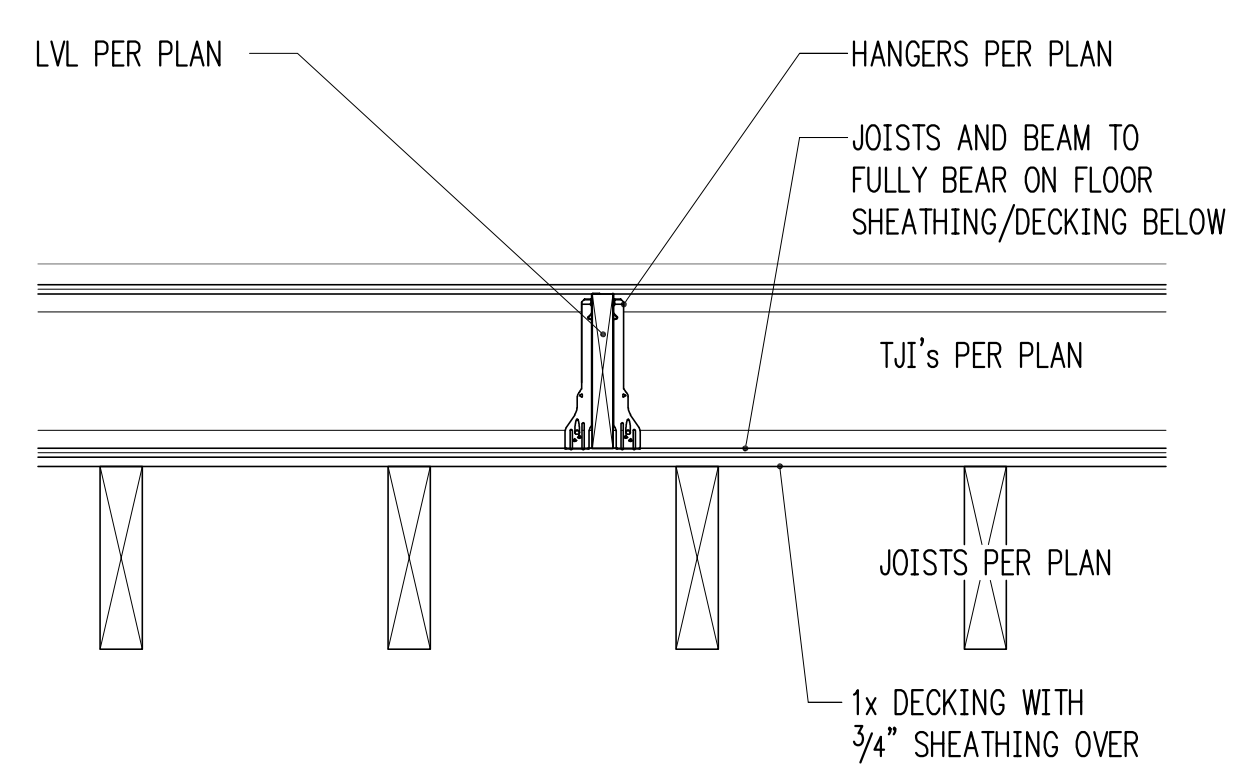

3/4" = 1'-0" 2

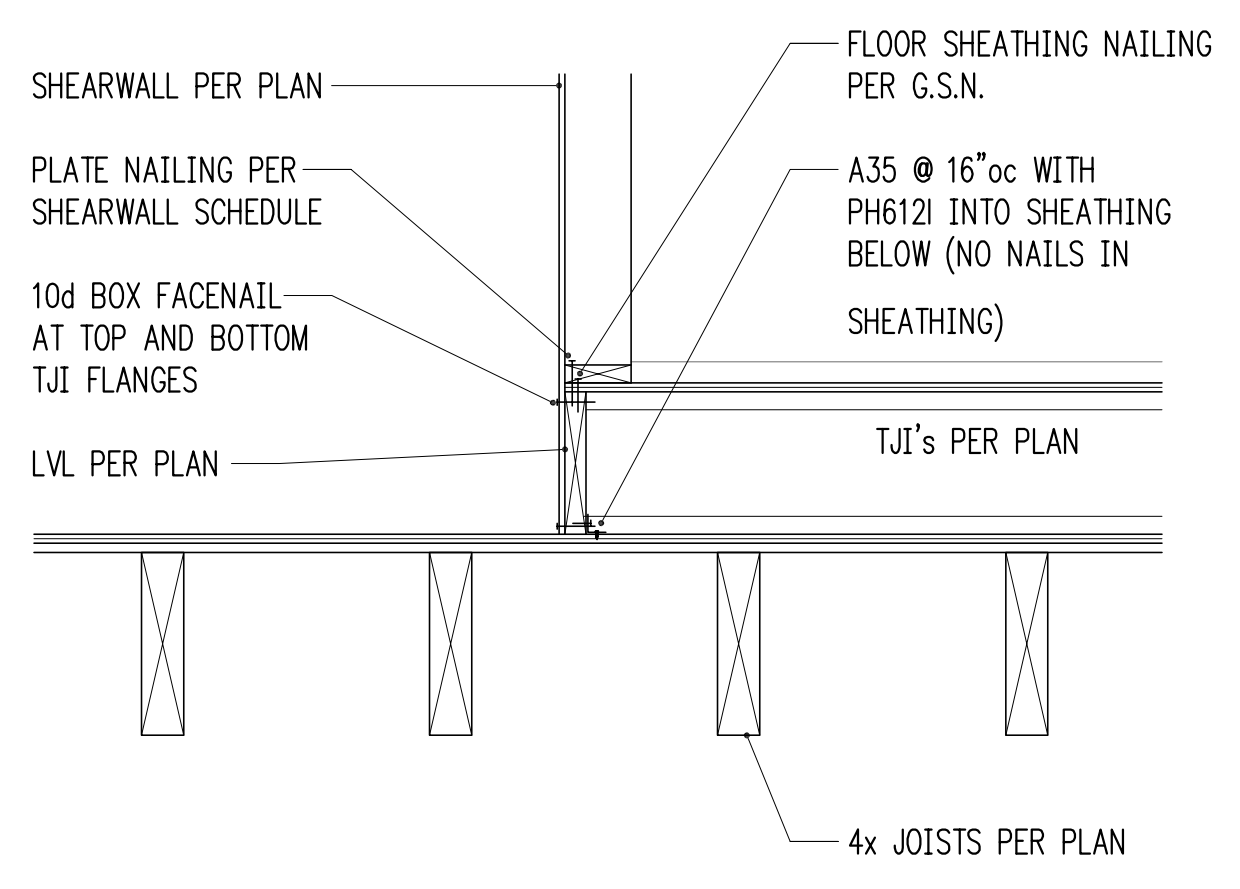

3/4" = 1'-0" 3

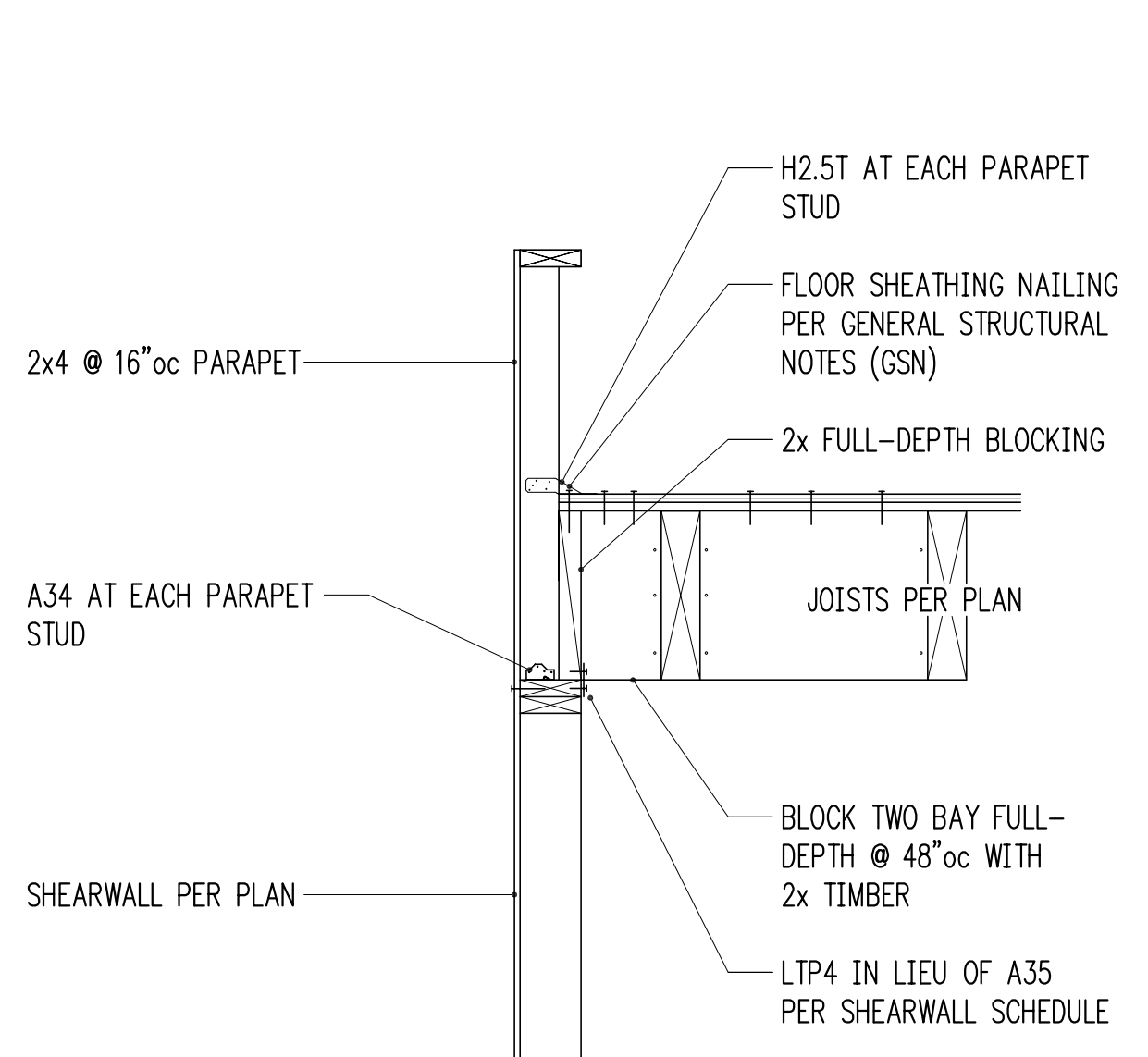

3/4" = 1'-0" 4

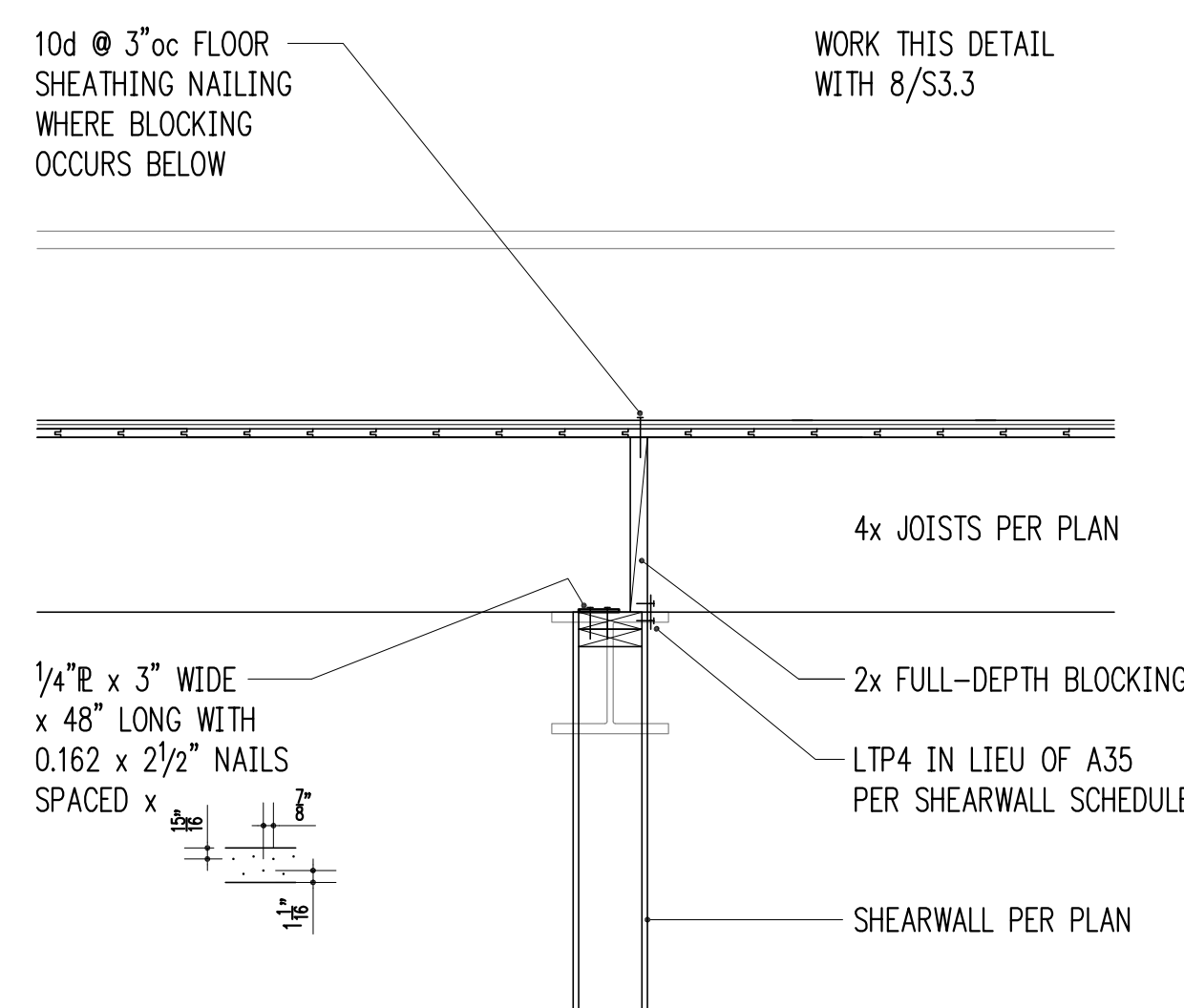

3/4" = 1'-0" 5

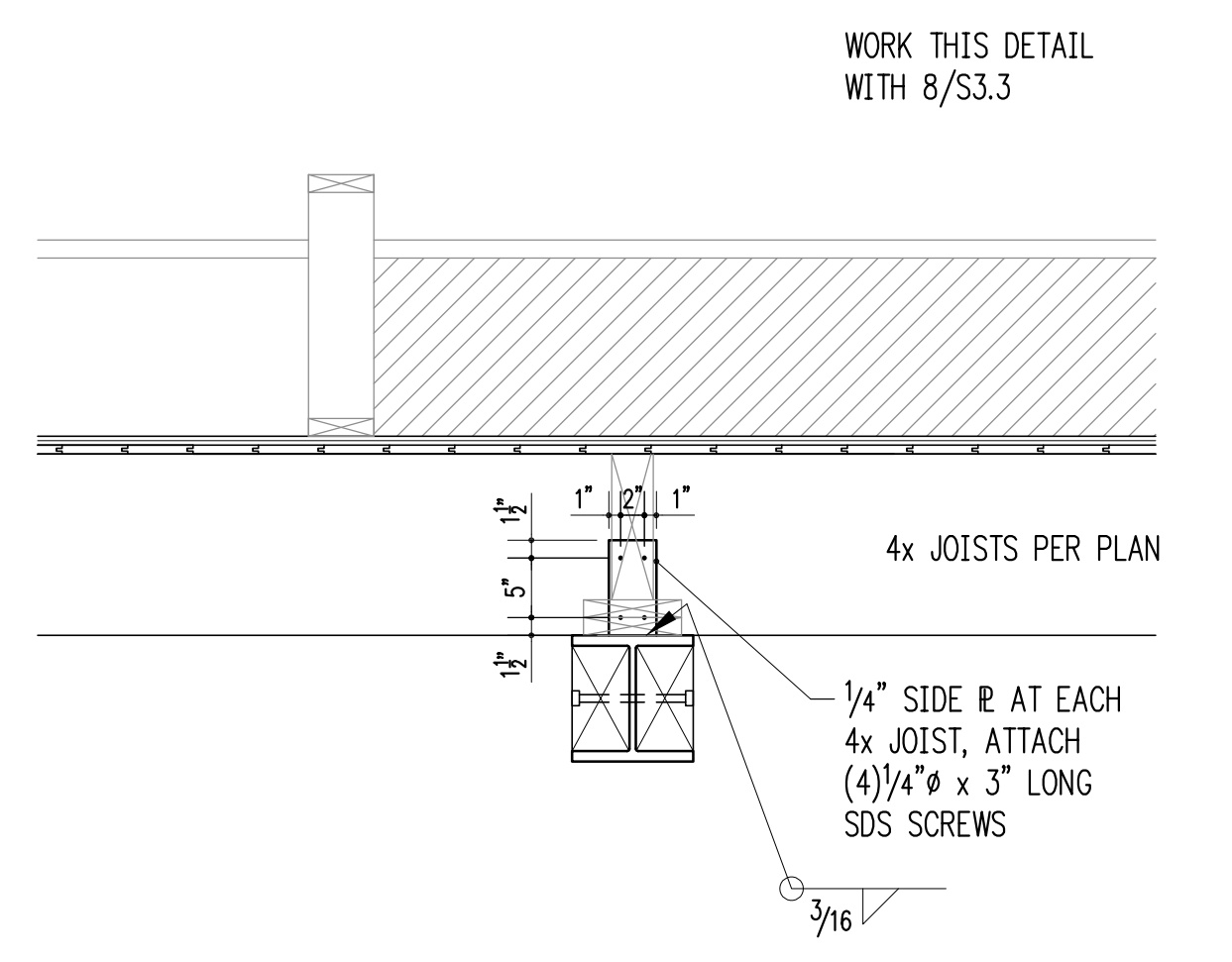

3/4" = 1'-0" 6

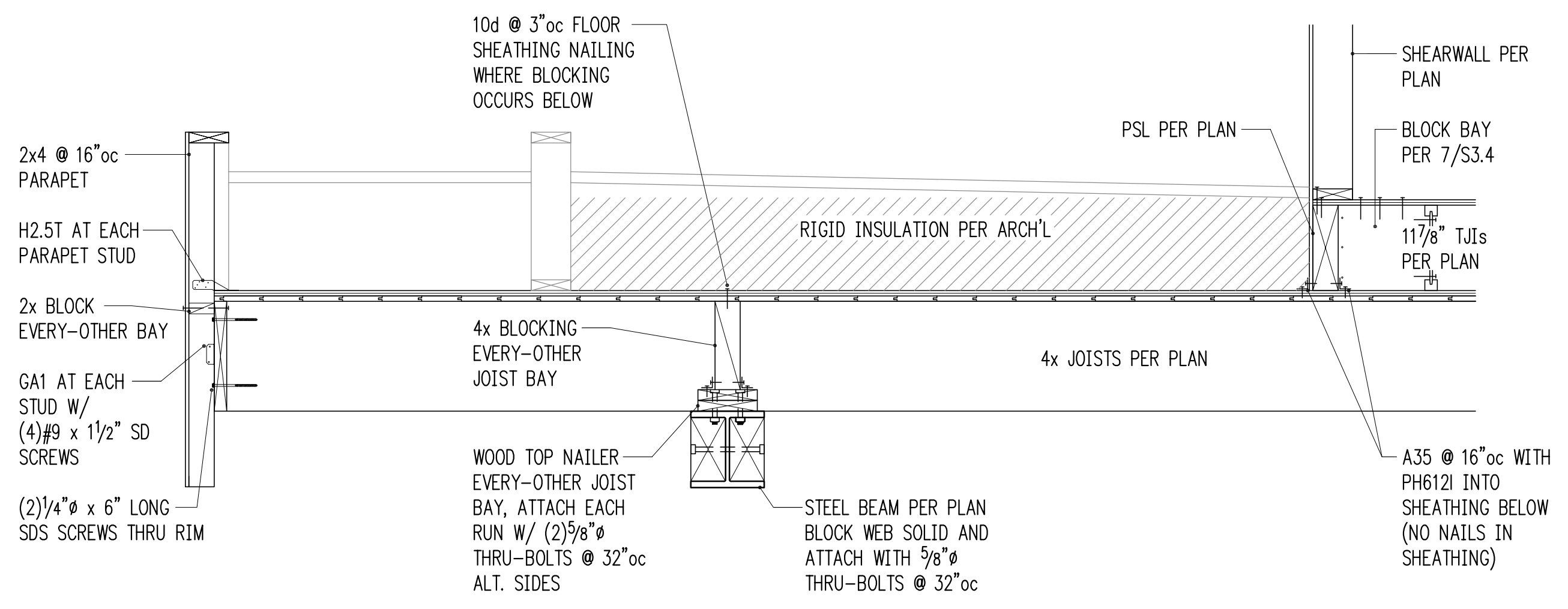

3/4" = 1'-0" 8

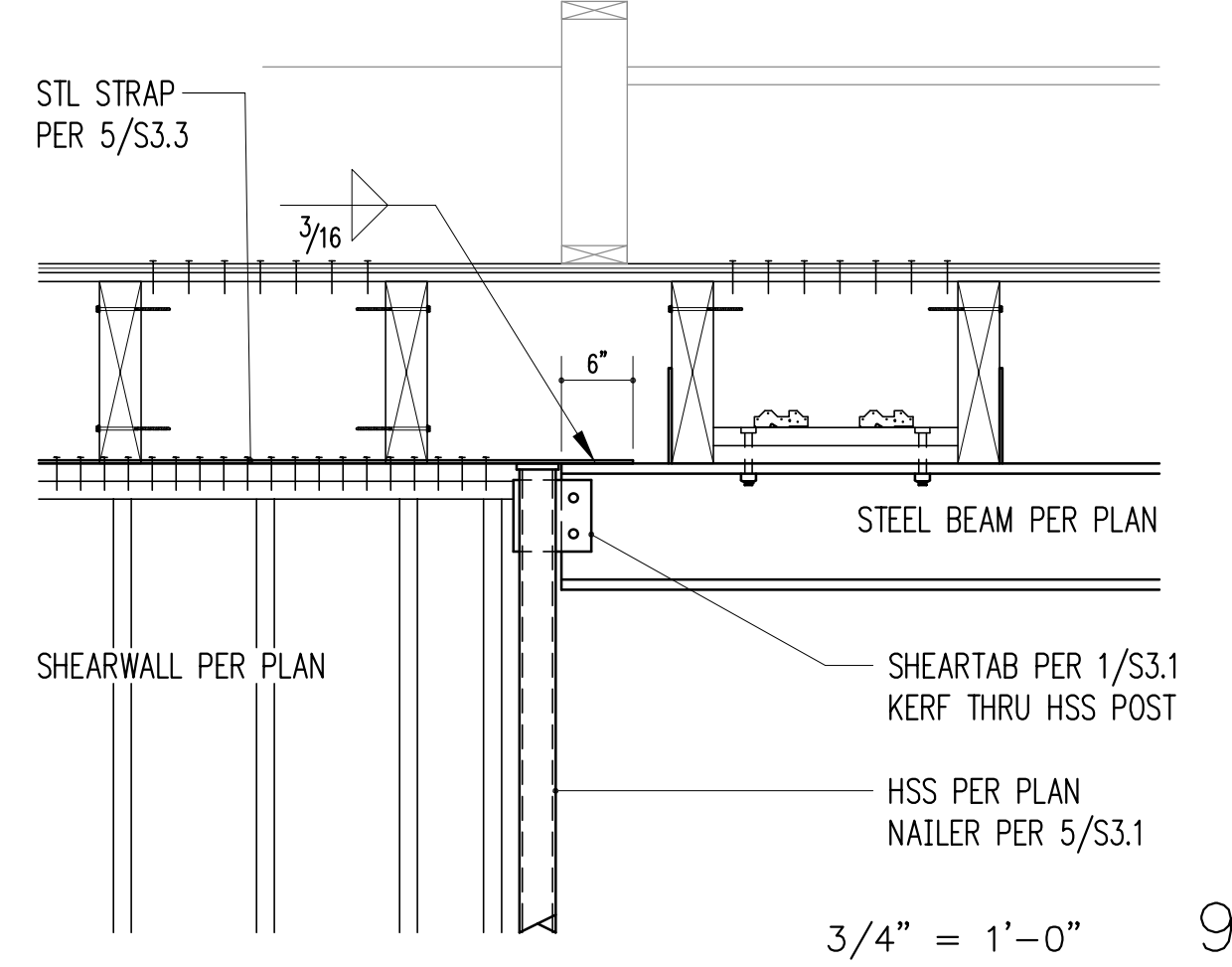

3/4" = 1'-0" 9

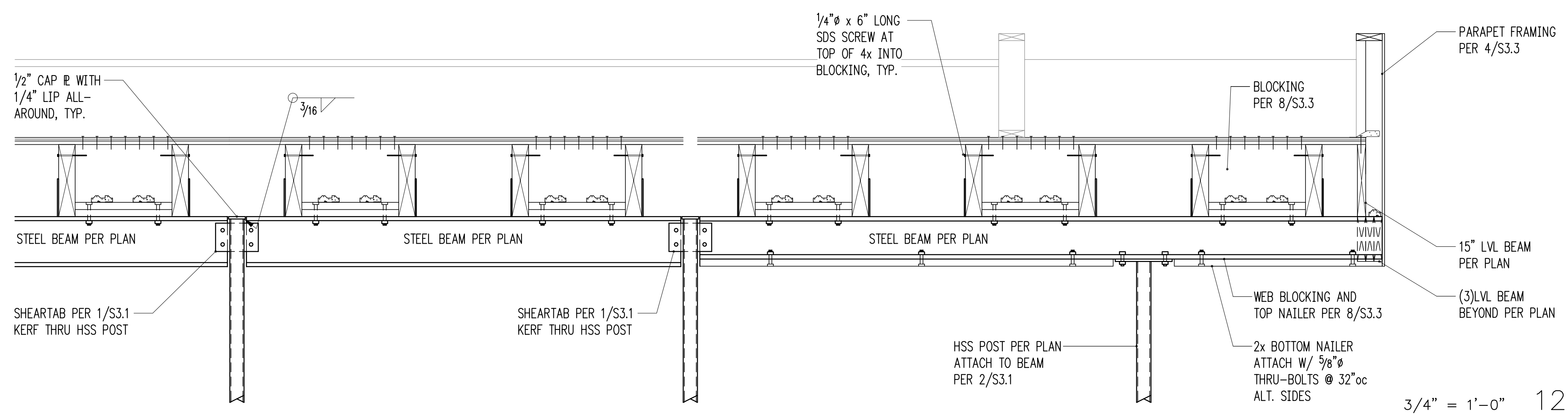

3/4" = 1'-0" 12

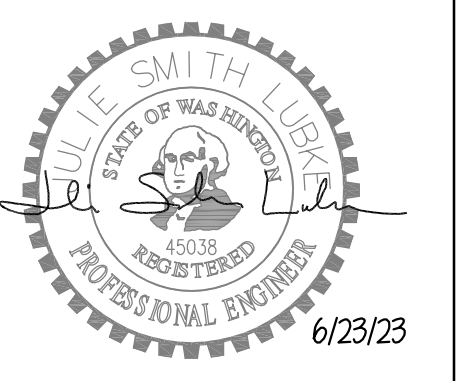

Issue Date	Issue Description
1/17/23	Permit
6/24/23	Building Revisions

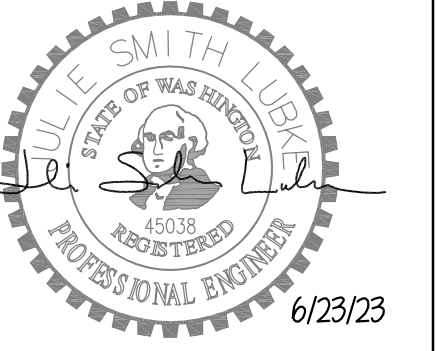

3/4" = 1'-0" 1

3/4" = 1'-0" 2

3/4" = 1'-0" 3

3/4" = 1'-0" 4

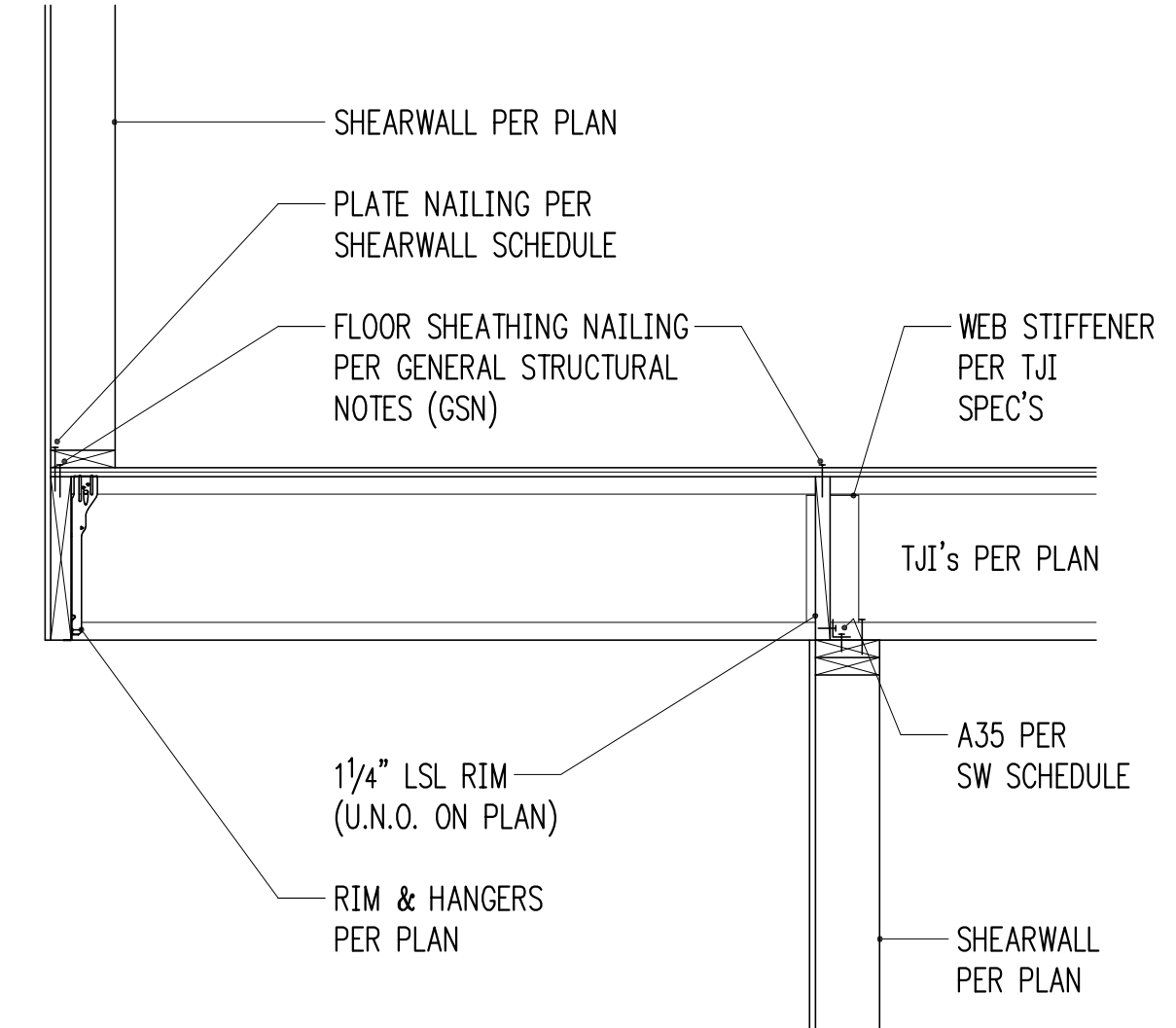

3/4" = 1'-0" 5

3/4" = 1'-0" 6

3/4" = 1'-0" 7

3/4" = 1'-0" 8

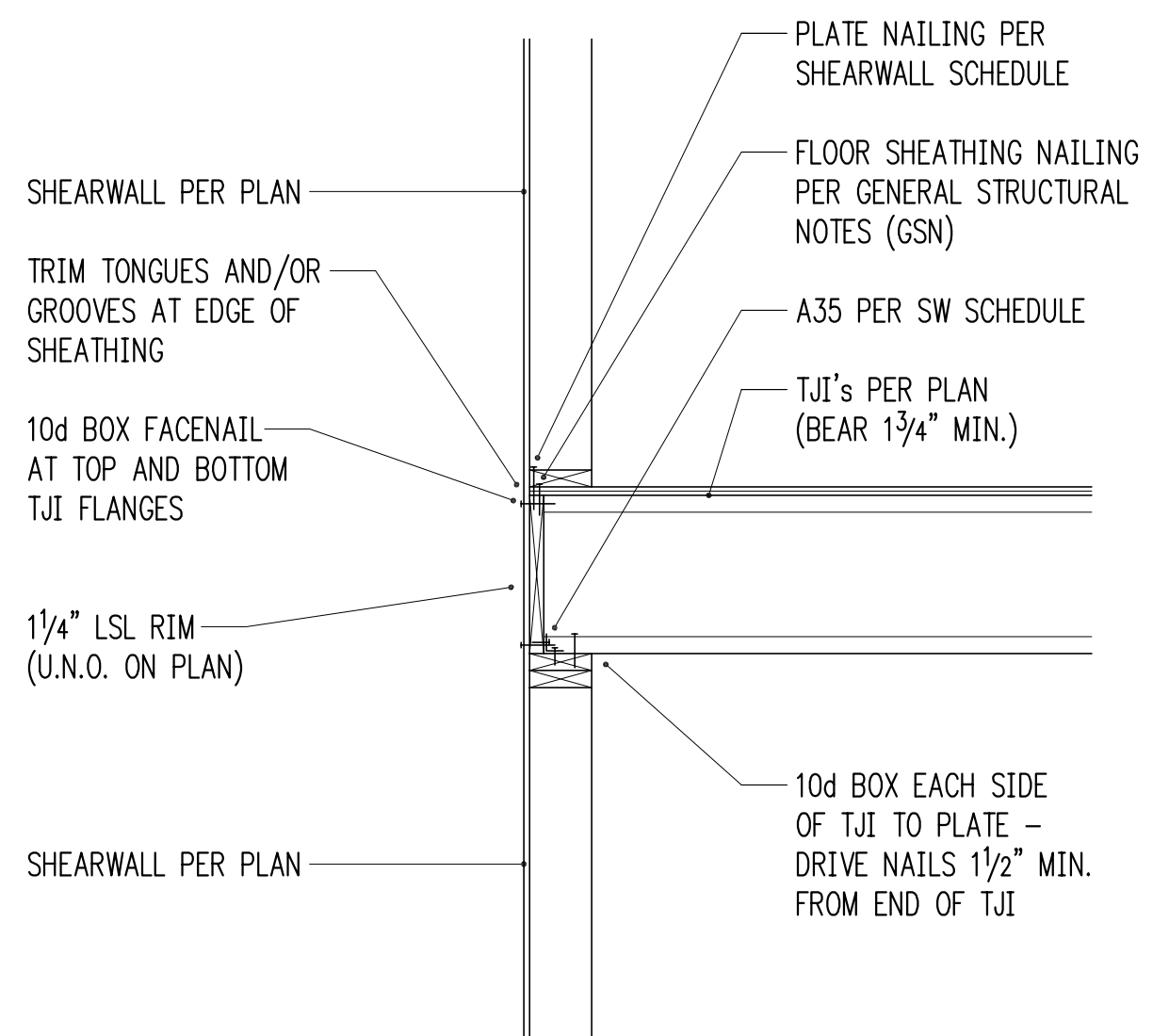
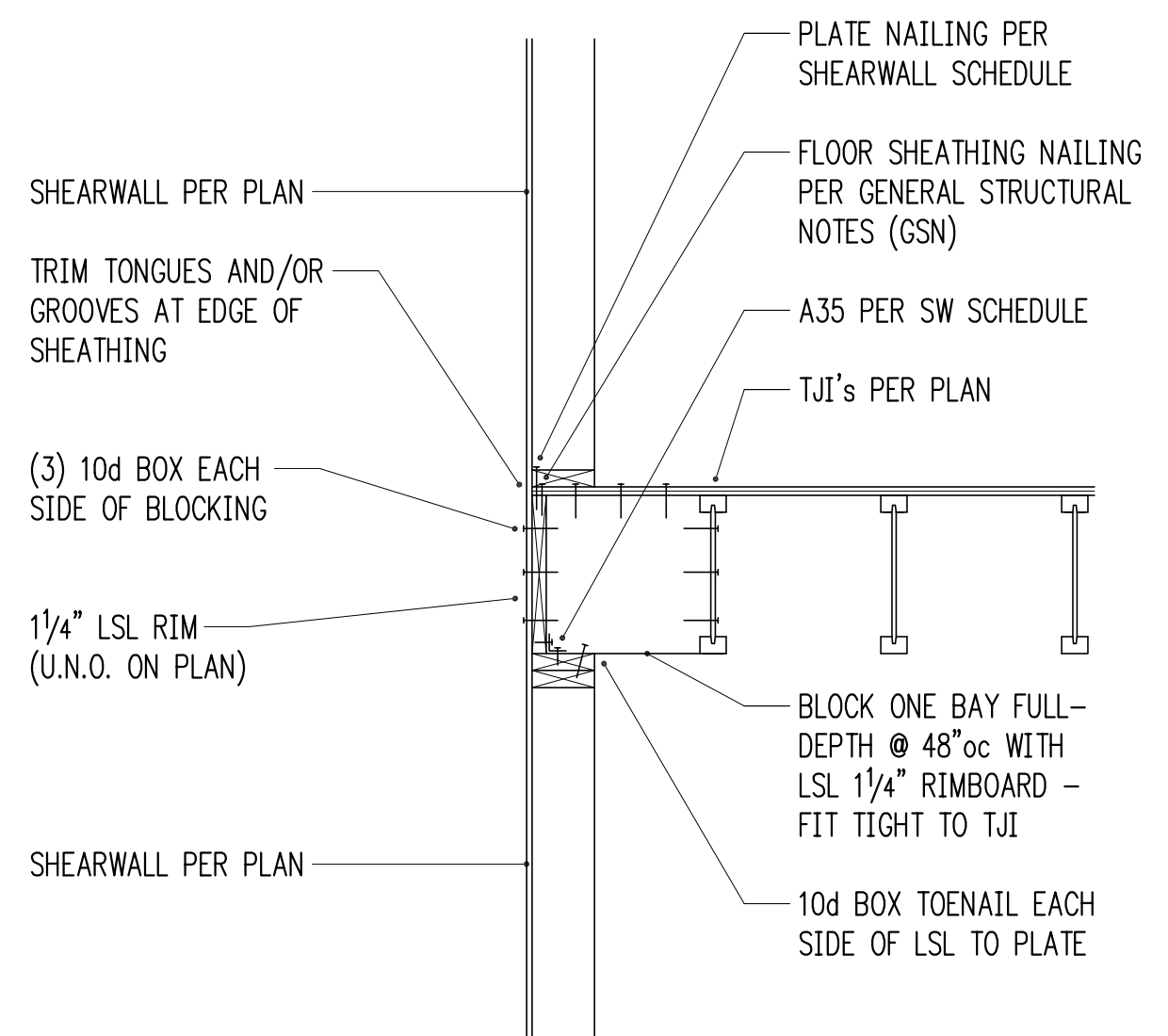

3/4" = 1'-0" 9

3/4" = 1'-0" 10

3/4" = 1'-0" 11

3/4" = 1'-0" 12

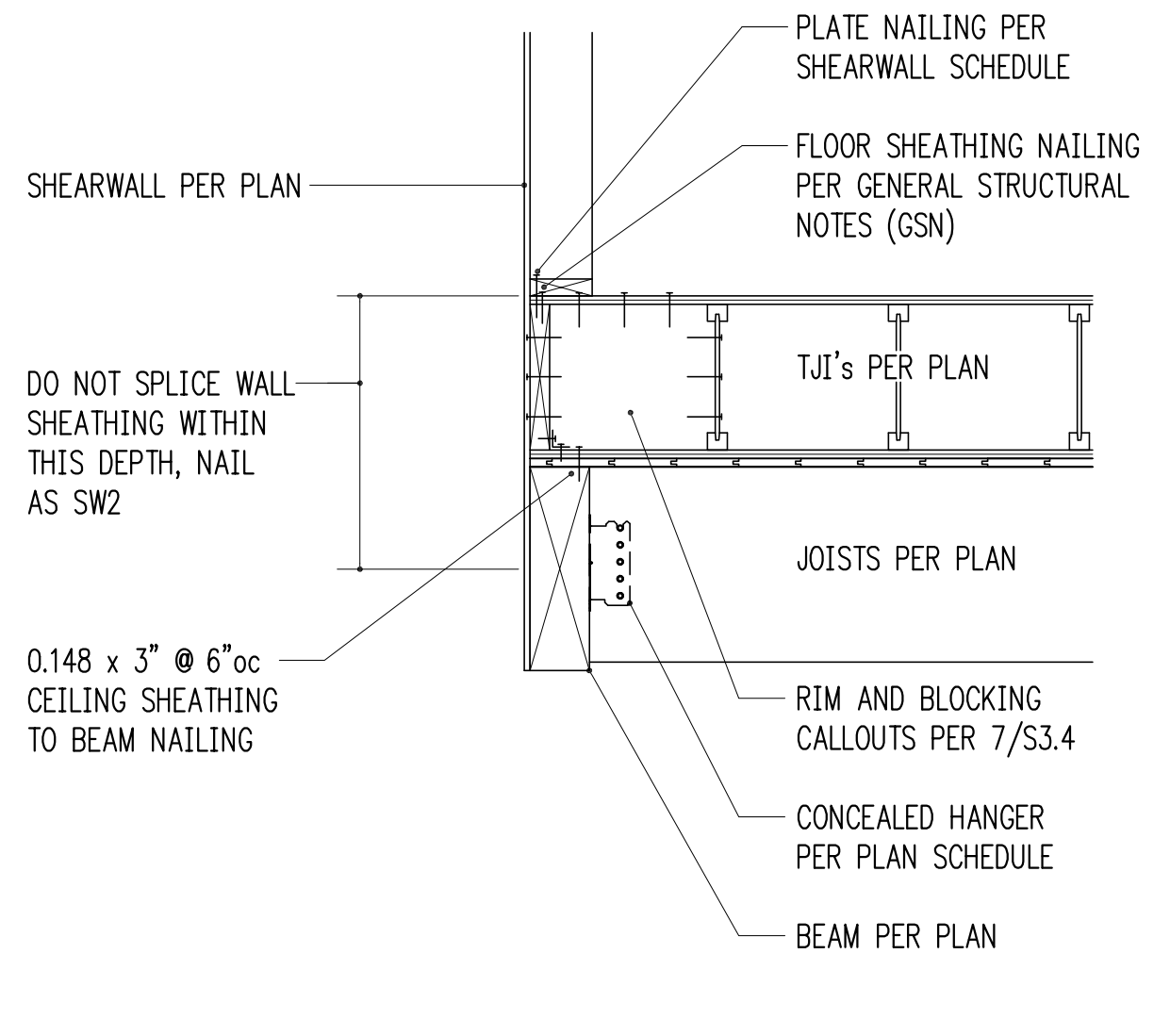
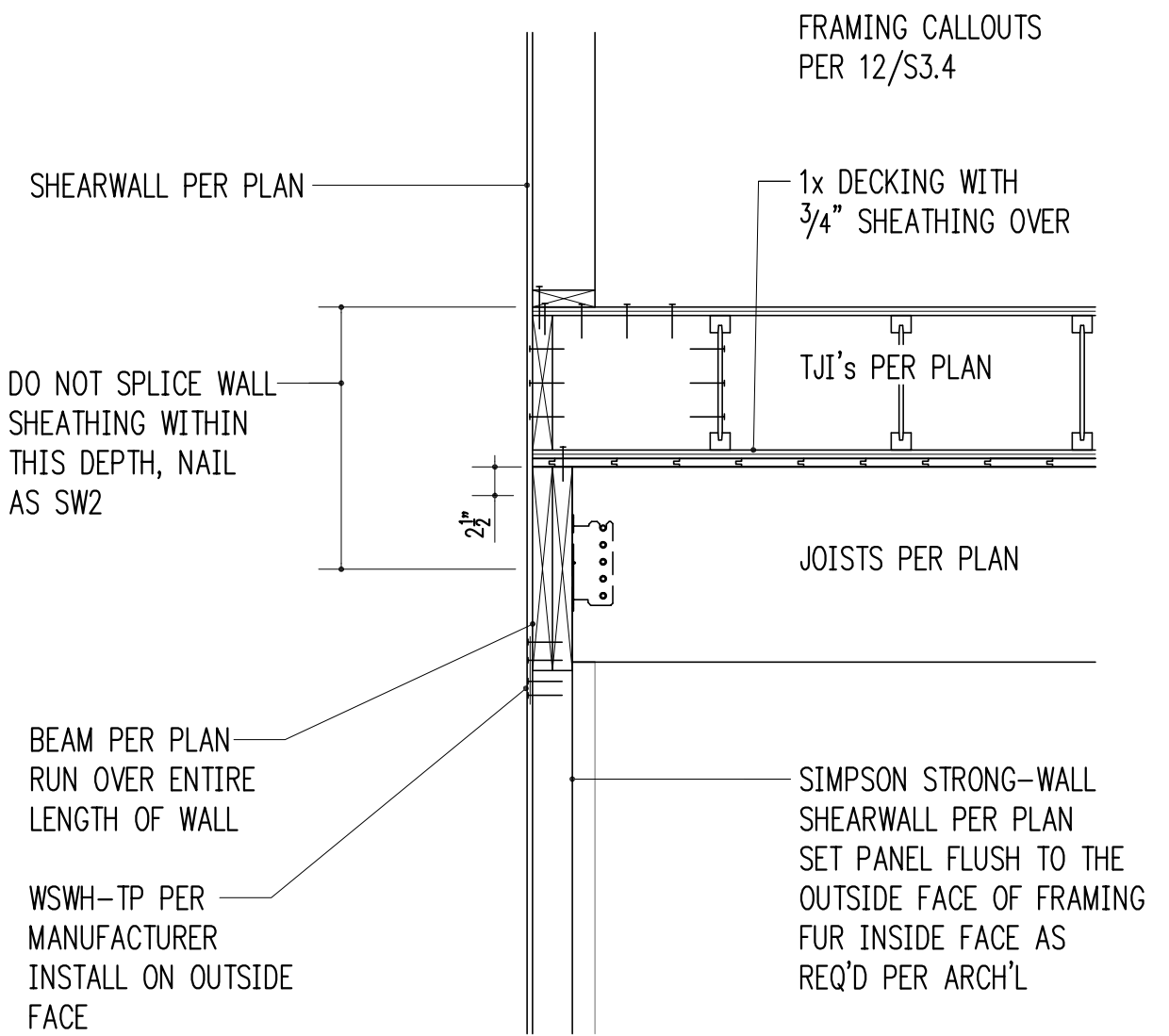
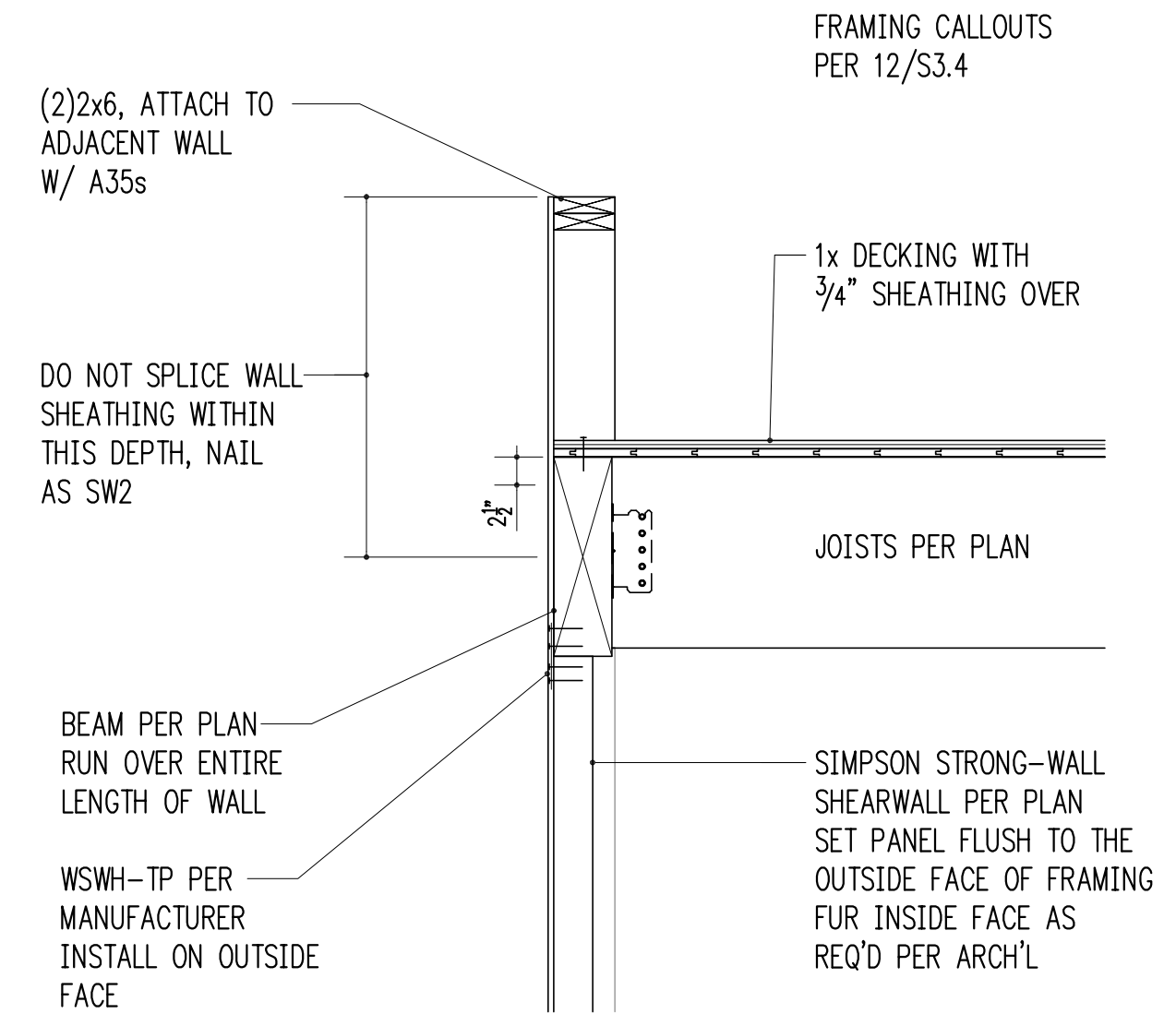

Sam + June
Mercer Island
3064 - 68th Avenue SE
Mercer Island, WA

Issue Date	Issue Description
1/17/23	Permit
6/24/23	Building Revisions

S3.4
STRUCTURAL DETAILS